

## Základné údaje o výkone - WAMAK TWW 600 EVI HeavyDuty 2L5

Vykurovanie - EN 14511		
Tepelný výkon [kW]	W10 / W35 (max)	619.7 ( 62.0 / 619.7 )
	W10 / W35 (min)	62.0 ( 62.0 / 619.7 )
	W10 / W34	619.9 ( 62.0 / 619.9 )
Elektrický príkon [kW]	W10 / W35 (max)	108.6 ( 10.6 / 108.6 )
	W10 / W35 (min)	10.6 ( 10.6 / 108.6 )
	W10 / W34	106.3 ( 15.1 / 154.8 )
Tepelná účinnosť [COP]	W10 / W35 (max)	5.71
	W10 / W35 (min)	5.85
	W10 / W34	5.83
Sezónna tepelná účinnosť vykurovania - SCOP EN 14825		
Stredná klim. zóna / Nízka teplota [35°C]	SCOP	6.50
	$\eta$ [%]	259.8
	Label	A+++
	Qhe [kWh]	197045.2
	Pdesignh [kW]	619.7
	Tbivalent [°C]	-10
Chladenie		
Chladiaci výkon - [kW]	A35 / W23-18	484.3
	A25 / W23-18	509.0
	A35 / W12-7	363.8
	A25 / W12-7	363.8
Sezónna účinnosť chladenia - SEER EN 14825		
[ W 23 / 18°C ]	SEER	5.15
	Qce [kWh]	53383.3
	$\eta_c$ [%]	205.8
Zvuk EN 12102		
Zvuk - výkon - Lw	dB(A)	77.3
Zvuk - tlak - Lp	1 m dB(A)	69.3
	5 m dB(A)	55.3
	10 m dB(A)	49.3
Strojné a prevádzkové informácie		
Typ kompresoru (3~ 400/50)	SCROLL / 10 /	Zap/Vyp
Chladivo	R410A (GWP - 2088)	5 x 11.5 kg
Prevádzkové hraničné teploty vykurovania - (min / max) [°C]		25 / <b>65</b>
Prevádzkové hraničné teploty zdroja - (min / max) [°C]		<b>-10 (7)</b> / 30
Váha zariadenia		3100 kg

## Hlavné technické údaje - WAMAK TWW 600 EVI HeavyDuty 2L5

Označenie krytovania		HD2L5		Údaje strany odovzdania tepelnej energie		
Základné rozmery	Výška [mm]	2000		Prevádzkové hraničné teploty vykurovania	MAX [°C]	65
	Šírka [mm]	3450			MIN [°C]	25
	Dĺžka [mm]	1200		viac vid. diagram prevádzkových limitov		
Váha zariadenia [kg]	3100		<b>Kondenzátor</b>	Pripojovacia dimenzia	5 x VIC 2.1/2 "	
Farba krytovania	Sivá			Typ	BPHE	
IP trieda krytovania	IP20			Počet	5	
				Materiál	AISI 316	
<b>Chladivový okruh</b>						
<b>Kompresor</b>	Typ	Scroll		Maximálny prevádzkový tlak - chladivo [bar]	50	
	Výkonové stupňe	10		Maximálny prevádzkový tlak - Voda [bar]	6	
	Zap/Vyp			Testovací pretlak [bar]	70	
	Účinník Cosφ	0.64		Teplonosné médium	Voda	
	Odpor vynutia kompresora	0.76 Ohm		Objemový prietok @ dT 5K (nom) - Voda [m3/h]	10.71 ~ 107	
Chladivo		R410A		Vnútorná tlaková strata - Voda [kPa]	5 x 20	
	Objem	5 x 11.5 kg		Teplotný spád @ 35°C (nom)	5 K	
	GWP	2088		@ 55°C	8 K	
	Bezpečnostná trieda	A1		@ 65°C	10 K	
Typ oleja v okruhu	POE RL32-3MAF			<b>Údaje strany odberu obnoviteľnej energie</b>		
	Objem oleja	10 x 3.38 L		Prevádzkové hraničné teploty zdroja	MIN [°C]	-10 (7)
Maximálny tlak chladiva [bar]		50			MAX [°C]	30
	PED trieda	2		viac vid. diagram prevádzkových limitov		
EVI - vstrek chladiva s ekonomizérom			<b>Výparník</b>	Pripojovacia dimenzia	5 x VIC 2.1/2 "	
				Typ	BPHE	
				Počet	5	
				Materiál	AISI 316	
			Maximálny prevádzkový tlak - chladivo [bar]	29		
			Teplonosné médium	Voda		
			Maximálny prevádzkový tlak - Voda [bar]	6		
			Objemový prietok - Voda [m3/h]	12.00 ~ 120		
			Vnútorná tlaková strata - Voda [kPa]	5 x 20		
			Teplotný spád - Voda	4 K		
<b>Údaje elektrického pripojenia</b>						
Elektro napájanie [#~ V/Hz]		3~ 400/50				
Prúd	nominálny [A]	235.30				
	maximálny [A]	374.00				
	štartovací [A]	57.2				
Softštartér	-					
Hlavný istič - charakteristika		C400				
<b>Riadiaci systém</b>						
Hlavný regulátor	SIEMENS RVS 61					
Rozširovací modul	AVS75.3xx	AVS75.3xx	AVS75.372			
Bus Clip-In	LPB OCI345		Modbus OCI351			
Online pripojenie	Web server OZW672		ToSyMo			
Regulácia EEV	SEC61					

\*\*\* s príslušenstvom

# WAMAK TWW 600 EVI HeavyDuty 2L5

## ErP (EU) No 811/2013: Technické parametre vykurovacích zariadení s tepelným čerpadlom

Model	TWW 600 EVI HeavyDuty 2L5
Tepelné čerpadlo vzduch-voda	nie
Tepelné čerpadlo soľanka-voda	nie
Tepelné čerpadlo voda-voda	áno
Nízkoteplotné tepelné čerpadlo	nie
Vybavené prídavným ohrievačom	nie
Kombinované tepelné čerpadlo s ohrievačom	nie
Teplotné použitie	nízka teplota (35 °C - 30 °C)
Klimatická oblasť	priemerná

Položka	Symbol	Hodnota	mj	Položka	Symbol	Hodnota	mj
Menovitý tepelný výkon pri Tdesignh	Prated	619.7	kW	Sezónna energetická účinnosť vykurovania priestoru	$\eta_s$	259.8	%
Deklarovaný výkon vykurovania pri čiastočnom zaťažení pri vnútornej teplote 20 °C a vonkajšej teplote Tj				Deklarovaný súčiniteľ výkonu alebo pomer primárnej energie pre čiastočné zaťaženie pri vnútornej teplote 20 °C a vonkajšej teplote Tj			
Tj = -7 °C	Pdh	619.9	kW	Tj = -7 °C	COPd	5.83	-
Tj = +2 °C	Pdh	620.6	kW	Tj = +2 °C	COPd	6.4	-
Tj = +7 °C	Pdh	621.0	kW	Tj = +7 °C	COPd	6.9	-
Tj = +12 °C	Pdh	621.2	kW	Tj = +12 °C	COPd	7.4	-
Tj = bivalentná teplota	Pdh	619.7	kW	Tj = bivalentná teplota	COPd	5.7	-
Tj = hraničná prevádzková teplota	Pdh	---	kW	Tj = hraničná prevádzková teplota	COPd	---	-
Bivalentná teplota	Tbiv	-10	°C	Tj = hraničná prevádzková teplota	TOL	---	°C
Spotreba energie v iných ako aktívnych režimoch				Medzná prevádzková teplota vykurovacej vody	WTOL	65	°C
Vypnuté	Poff	0.010	kW	Prídavný ohrievač			
Režim vypnutia termostatu	Pto	0.010	kW	Menovitý tepelný výkon	Psup	94.9	kW
Pohotovostný režim	Psb	0.010	kW	Typ príkonu energie	elektrická		
Režim ohrevu kľukovej skrine	Pck	0.000	kW				
Ostatné položky							
Regulácia výkonu	viacero stupňov			Pre tepelné čerpadlá vzduch-voda: Menovitý prietok vzduchu, vonku	-	---	m <sup>3</sup> /h
Úroveň akustického výkonu				Pre tepelné čerpadlá voda-voda alebo soľanka-voda: Menovitý prietok soľanky alebo vody, vonkajší výmenník tepla	-	12.00 ~ 120	m <sup>3</sup> /h
v interiéri	Lwa	77	dB				
vonku	Lwa	---	dB				
Ročná spotreba energie	Q <sub>HE</sub>	197045.2	kWh				

**Kontaktné údaje:** WAMAK, s.r.o., Orovnica 252, 96652, Orovnica, Slovakia, info@wamak.sk

# WAMAK TWW 600 EVI HeavyDuty 2L5

## ErP (EU) No 811/2013: Technické parametre vykurovacích zariadení s tepelným čerpadlom

<b>Model</b>	<b>TWW 600 EVI HeavyDuty 2L5</b>
Tepelné čerpadlo vzduch-voda	nie
Tepelné čerpadlo soľanka-voda	nie
Tepelné čerpadlo voda-voda	áno
Nízkotepelné tepelné čerpadlo	nie
Vybavené prídavným ohrievačom	nie
Kombinované tepelné čerpadlo s ohrievačom	nie
Teplotné použitie	stredá teplota (55°C - 47°C)
Klimatická oblasť	priemerná

Položka	Symbol	Hodnota	mj	Položka	Symbol	Hodnota	mj
Menovitý tepelný výkon pri Tdesignh	Prated	616.8	kW	Sezónna energetická účinnosť vykurovania priestoru	$\eta_s$	201.5	%
Deklarovaný výkon vykurovania pri čiastočnom zaťažení pri vnútornej teplote 20 °C a vonkajšej teplote Tj				Deklarovaný súčiniteľ výkonu alebo pomer primárnej energie pre čiastočné zaťaženie pri vnútornej teplote 20 °C a vonkajšej teplote Tj			
Tj = -7 °C	Pdh	623.2	kW	Tj = -7 °C	COPd	4.03	-
Tj = +2 °C	Pdh	625.4	kW	Tj = +2 °C	COPd	5.2	-
Tj = +7 °C	Pdh	626.8	kW	Tj = +7 °C	COPd	6.0	-
Tj = +12 °C	Pdh	627.9	kW	Tj = +12 °C	COPd	6.6	-
Tj = bivalentná teplota	Pdh	616.8	kW	Tj = bivalentná teplota	COPd	3.6	-
Tj = hraničná prevádzková teplota	Pdh	---	kW	Tj = hraničná prevádzková teplota	COPd	---	-
Bivalentná teplota	Tbiv	-10	°C	Tj = hraničná prevádzková teplota	TOL	---	°C
<b>Spotreba energie v iných ako aktívnych režimoch</b>				Medzná prevádzková teplota vykurovacej vody	WTOL	65	°C
Vypnuté	Poff	0.010	kW	<b>Prídavný ohrievač</b>			
Režim vypnutia termostatu	Pto	0.010	kW	Menovitý tepelný výkon	Psup	94.9	kW
Pohotovostný režim	Psb	0.010	kW	Typ príkonu energie	elektrická		
Režim ohrevu kľukovej skrine	Pck	0.000	kW				
<b>Ostatné položky</b>							
Regulácia výkonu	viacero stupňov			Pre tepelné čerpadlá vzduch-voda: Menovitý prietok vzduchu, vonku	-	---	m <sup>3</sup> /h
Úroveň akustického výkonu				Pre tepelné čerpadlá voda-voda alebo soľanka-voda: Menovitý prietok soľanky alebo vody, vonkajší výmenník tepla	-	12.00 ~ 120	m <sup>3</sup> /h
v interiéri	Lwa	77	dB				
vonku	Lwa	---	dB				
Ročná spotreba energie	Q <sub>HE</sub>	252829.4	kWh				

**Kontaktné údaje:** WAMAK, s.r.o., Orovnica 252, 96652, Orovnica, Slovakia, info@wamak.sk



**ENERG** Y IJA  
 енергия - ενεργεια IE IA



TWW 600 EVI  
 HeavyDuty 2L5



55 °C

35 °C



A+++

A+++



77 dB



--- dB

■ 648	■ 633
■ 617	■ 620
■ 605	■ 589
kW	kW



2019

811/2013

TWW 600 EVI  
 HeavyDuty 2L5

**ErP Data**

	55 °C	35 °C
Energy class	A+++	A+++
$\eta$ [%]	201.5	259.8
$P_{rated}$ [kW]	617	620
$Q_{HE}$ [kWh/y]	252830	197046
SCOP [-]	5.04	6.50
$T_{bivalent}$ [°C]	-10	-10

CONTROLLER



+ QAA55/75 class VII 3.5% ↓  
 - QAA55/75 class III 1.5% ↓

Tepelný výkon - prevádzkové dáta

Version: v2024.004-BW-WW

Zdroj - soľanka [0°C] / Nízka teplota [35°C]

ZHI46K1P-TWD\_R410A\_10\_BWW

Prevádzkový bod	Qh	P	COP
1 B0 / W30-35	492.1	108.6	4.53
2 B0 / W30-35 ( MIN )	49.2	10.6	4.65
A B0 / Wxx-34	491.6	106.2	4.63
B B0 / Wxx-30	489.2	97.1	5.04
C B0 / Wxx-27	48.7	8.8	5.51
D B0 / Wxx-24	48.5	8.2	5.88
E B0 / Wxx-35	492.1	108.6	4.53
F B0 / Wxx-35	492.1	108.6	4.53

SCOP DATA EN 14825:2018	
Zdroj - soľanka [0°C] / Nízka teplota [35°C]	
SCOPon	3.12
SCOPnet	6.01
SCOP	3.12
η [ % ]	124.63
Label	A+
Qh [ kWh ]	1016679
Pdesignh [ kW ]	492.1
Tbivalent [ °C ]	-10

Zdroj - soľanka [0°C] / Stredná teplota [55°C]

Prevádzkový bod	Qh	P	COP
1 B0 / W47-55	502.0	170.2	2.95
2 B0 / W47-55 ( MIN )	50.2	16.6	3.02
A B0 / Wxx-52	505.3	155.3	3.36
B B0 / Wxx-42	506.1	121.2	4.22
C B0 / Wxx-36	49.8	10.5	4.75
D B0 / Wxx-30	49.5	9.5	5.23
E B0 / Wxx-55	502.0	170.2	2.95
F B0 / Wxx-54	505.8	158.9	3.18

SCOP DATA EN 14825:2018	
Zdroj - soľanka [0°C] / Stredná teplota [55°C]	
SCOPon	2.74
SCOPnet	4.75
SCOP	2.74
η [ % ]	109.41
Label	A+
Qh [ kWh ]	1037132
Pdesignh [ kW ]	502.0
Tbivalent [ °C ]	-10

Zdroj - voda [10°C] / Nízka teplota [35°C]

Prevádzkový bod	Qh	P	COP
1 W10 / W30-35	619.7	108.6	5.71
2 W10 / W30-35 ( MIN )	62.0	10.6	5.85
A W10 / Wxx-34	619.9	106.3	5.83
B W10 / Wxx-30	620.6	97.7	6.35
C W10 / Wxx-27	62.1	8.9	6.94
D W10 / Wxx-24	62.1	8.4	7.40
E W10 / Wxx-35	619.7	108.6	5.71
F W10 / Wxx-35	619.7	108.6	5.71

SCOP DATA EN 14825:2018	
Zdroj - voda [10°C] / Nízka teplota [35°C]	
SCOPon	3.51
SCOPnet	7.56
SCOP	3.51
η [ % ]	140.30
Label	A++
Qh [ kWh ]	1280300
Pdesignh [ kW ]	619.7
Tbivalent [ °C ]	-10.00

## WAMAK TWW 600 EVI HeavyDuty 2L5

### Zdroj - voda [10°C] / Stredná teplota [55°C]

	Prevádzkový bod	Qh	P	COP
1	W10 / W47-55	616.8	170.1	3.63
2	W10 / W47-55 ( MIN )	61.7	16.6	3.72
A	W10 / Wxx-52	623.2	154.8	4.03
B	W10 / Wxx-42	625.4	120.9	5.17
C	W10 / Wxx-36	62.7	10.5	5.98
D	W10 / Wxx-30	62.8	9.5	6.58
E	W10 / Wxx-55	616.8	170.1	3.63
F	W10 / Wxx-55	616.8	170.1	3.63

SCOP DATA EN 14825:2018	
Zdroj - voda [10°C] / Stredná teplota [55°C]	
SCOPon	3.08
SCOPnet	5.76
SCOP	3.08
η [ % ]	123.21
Label	A+
Qh [ kWh ]	1274309
Pdesignh [ kW ]	616.8
Tbivalent [ °C ]	-10.00

### Nízkokoteplotné chladenie W 12 / 7°C

	Prevádzkový bod	Qc	P	EER
A	W30-35 / W12-7	373.9	116.0	3.22
B	W26-xx / W12-7	380.8	106.2	3.59
C	W22-xx / W12-7	386.7	97.1	3.98
D	W18-xx / W12-7	389.3	92.8	4.20

SEER DATA EN 14825:2018 [ W 12 / 7°C ]	
SEERon	3.86
SEER	3.86
Qc [ kWh ]	218280
η [ % ]	154.51

### Plošné chladenie W 23 / 18°C

	Prevádzkový bod	Qc	P	EER
A	W50-xx / W23-18	434.4	182.4	2.38
B	W40-xx / W23-18	469.4	145.0	3.24
C	W30-35 / W23-18	497.4	116.0	4.29
D	W26-xx / W23-18	506.8	106.2	4.77

SEER DATA EN 14825:2018 [ W 23 / 18°C ]	
SEERon	5.15
SEER	5.15
Qc [ kWh ]	218280
η [ % ]	205.82

Výkonové kryvky - vykurovanie

— Qh-nom-35   
 - - - Qh-min-35   
 - - - - - Qh-max-65   
 — Qh-nom-45   
 — Qh-nom-55  
— Qh-nom-65

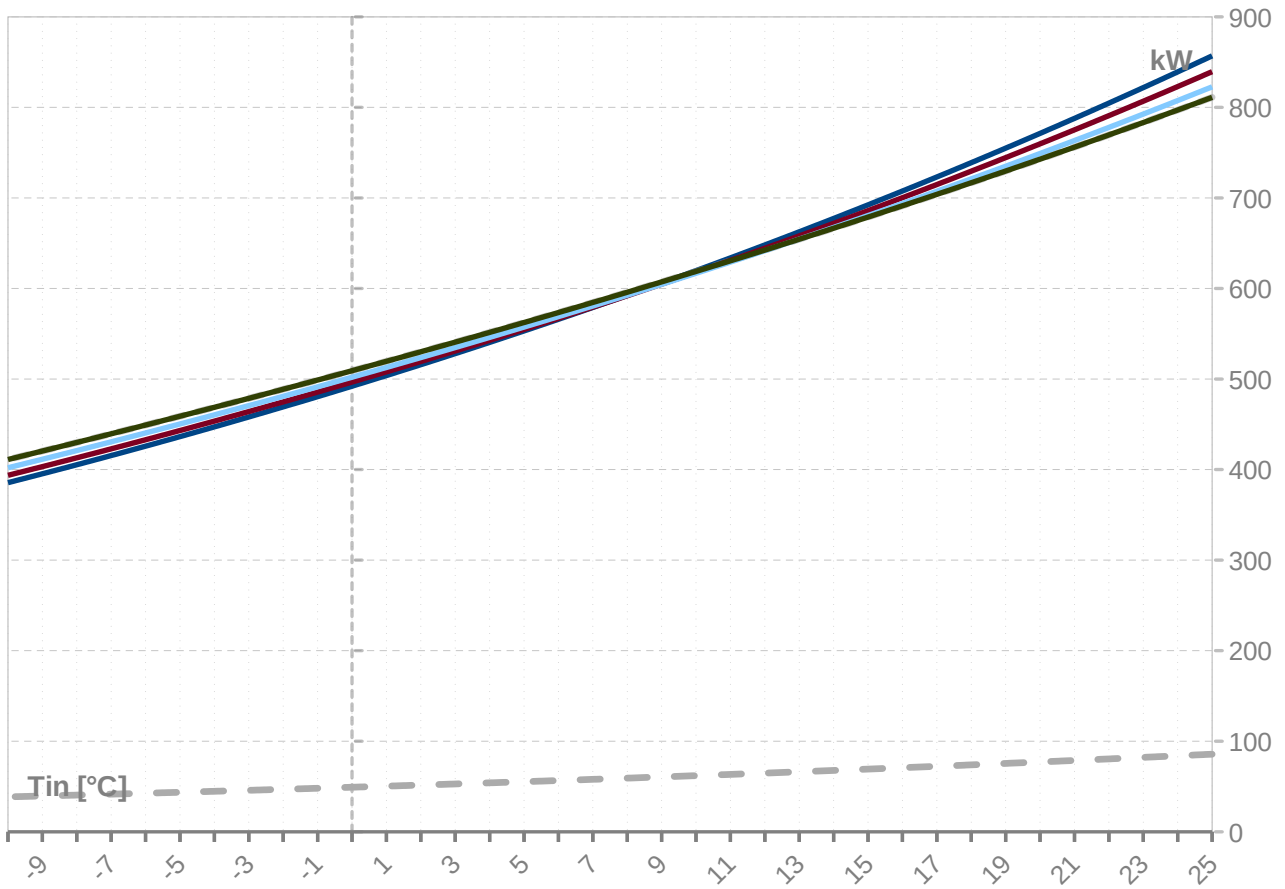

Výkonové kryvky - chladenie

— Qc-nom-12-7   
 — Qc-nom-23-18

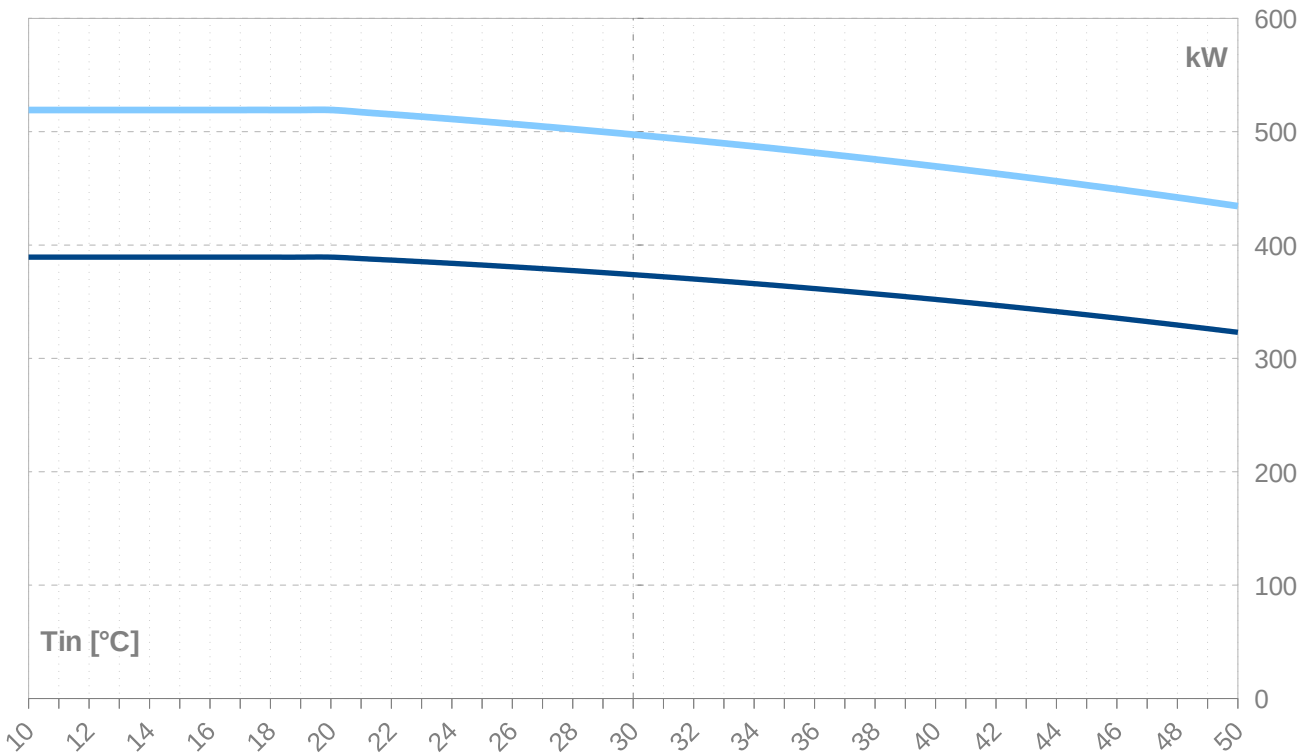

Tv -VY	35										
[°C]	Qh nom [kW]	Qh min [kW]	Qh max [kW]	Pin nom [kW]	Pin min [kW]	Pin max [kW]	COP nom kW / kW	Qc nom [kW]	Qc min [kW]	Qc max [kW]	I nom [A]
25	856.9	85.7	856.9	110.9	10.8	110.9	7.73	753.3	75.3	753.3	234.5
24	839.2	83.9	839.2	110.6	10.8	110.6	7.59	735.9	73.6	735.9	234.0
23	821.8	82.2	821.8	110.3	10.8	110.3	7.45	718.8	71.9	718.8	233.6
22	804.7	80.5	804.7	110.0	10.7	110.0	7.31	701.9	70.2	701.9	233.2
21	787.8	78.8	787.8	109.8	10.7	109.8	7.18	685.3	68.5	685.3	232.9
20	771.3	77.1	771.3	109.6	10.7	109.6	7.04	668.9	66.9	668.9	232.7
19	755.0	75.5	755.0	109.4	10.7	109.4	6.90	652.8	65.3	652.8	232.5
18	738.9	73.9	738.9	109.2	10.7	109.2	6.76	636.9	63.7	636.9	232.4
17	723.1	72.3	723.1	109.1	10.6	109.1	6.63	621.3	62.1	621.3	232.3
16	707.6	70.8	707.6	109.0	10.6	109.0	6.49	605.8	60.6	605.8	232.3
15	692.3	69.2	692.3	108.9	10.6	108.9	6.36	590.7	59.1	590.7	232.4
14	677.3	67.7	677.3	108.8	10.6	108.8	6.23	575.7	57.6	575.7	232.4
13	662.6	66.3	662.6	108.7	10.6	108.7	6.10	561.0	56.1	561.0	232.5
12	648.0	64.8	648.0	108.6	10.6	108.6	5.96	546.6	54.7	546.6	232.7
11	633.8	63.4	633.8	108.6	10.6	108.6	5.84	532.4	53.2	532.4	232.8
10	619.7	62.0	619.7	108.6	10.6	108.6	5.71	518.4	51.8	518.4	233.0
9	605.9	60.6	605.9	108.5	10.6	108.5	5.58	504.6	50.5	504.6	233.2
8	592.4	59.2	592.4	108.5	10.6	108.5	5.46	491.0	49.1	491.0	233.5
7	579.1	57.9	579.1	108.5	10.6	108.5	5.34	477.7	47.8	477.7	233.7
6	566.0	56.6	566.0	108.5	10.6	108.5	5.22	464.6	46.5	464.6	234.0
5	553.1	55.3	553.1	108.5	10.6	108.5	5.10	451.8	45.2	451.8	234.3
4	540.5	54.0	540.5	108.5	10.6	108.5	4.98	439.1	43.9	439.1	234.6
3	528.1	52.8	528.1	108.5	10.6	108.5	4.87	426.7	42.7	426.7	234.9
2	515.9	51.6	515.9	108.5	10.6	108.5	4.75	414.5	41.4	414.5	235.1
1	503.9	50.4	503.9	108.6	10.6	108.6	4.64	402.5	40.3	402.5	235.4
0	492.1	49.2	492.1	108.6	10.6	108.6	4.53	390.7	39.1	390.7	235.7
-1	480.5	48.1	480.5	108.6	10.6	108.6	4.43	379.2	37.9	379.2	236.0
-2	469.2	46.9	469.2	108.6	10.6	108.6	4.32	367.8	36.8	367.8	236.3
-3	458.0	45.8	458.0	108.5	10.6	108.5	4.22	356.7	35.7	356.7	236.5
-4	447.1	44.7	447.1	108.5	10.6	108.5	4.12	345.8	34.6	345.8	236.7
-5	436.4	43.6	436.4	108.5	10.6	108.5	4.02	335.0	33.5	335.0	236.9
-6	425.8	42.6	425.8	108.5	10.6	108.5	3.93	324.5	32.5	324.5	237.1
-7	415.4	41.5	415.4	108.4	10.6	108.4	3.83	314.2	31.4	314.2	237.3
-8	405.3	40.5	405.3	108.4	10.6	108.4	3.74	304.1	30.4	304.1	237.4
-9	395.3	39.5	395.3	108.3	10.6	108.3	3.65	294.2	29.4	294.2	237.4
-10	385.5	38.6	385.5	108.2	10.6	108.2	3.56	284.5	28.4	284.5	237.5
-11	375.9	37.6	375.9	108.1	10.5	108.1	3.48	275.0	27.5	275.0	237.5
-12	366.5	36.6	366.5	108.0	10.5	108.0	3.39	265.7	26.6	265.7	237.4
-13	357.2	35.7	357.2	107.8	10.5	107.8	3.31	256.5	25.7	256.5	237.3
-14	348.1	34.8	348.1	107.6	10.5	107.6	3.23	247.6	24.8	247.6	237.2
-15	339.2	33.9	339.2	107.4	10.5	107.4	3.16	238.9	23.9	238.9	237.0

-- pozor: pracovný rozsah nie je zohľadnený v tabuľke

ZHI46K1P-TWD\_R410A\_10\_BWW

Tv -VY	45										
[°C]	Qh nom	Qh min	Qh max	Pin nom	Pin min	Pin max	COP nom	Qc nom	Qc min	Qc max	I nom
[°C]	[kW]	[kW]	[kW]	[kW]	[kW]	[kW]	kW / kW	[kW]	[kW]	[kW]	[A]
25	<b>839.4</b>	83.9	839.4	<b>133.3</b>	13.0	133.3	<b>6.30</b>	714.9	71.5	714.9	264.7
24	<b>823.0</b>	82.3	823.0	<b>133.2</b>	13.0	133.2	<b>6.18</b>	698.5	69.9	698.5	264.4
23	<b>806.8</b>	80.7	806.8	<b>133.2</b>	13.0	133.2	<b>6.06</b>	682.4	68.2	682.4	264.1
22	<b>790.8</b>	79.1	790.8	<b>133.1</b>	13.0	133.1	<b>5.94</b>	666.5	66.7	666.5	263.9
21	<b>775.2</b>	77.5	775.2	<b>133.1</b>	13.0	133.1	<b>5.82</b>	650.9	65.1	650.9	263.7
20	<b>759.7</b>	76.0	759.7	<b>133.1</b>	13.0	133.1	<b>5.71</b>	635.4	63.5	635.4	263.6
19	<b>744.5</b>	74.4	744.5	<b>133.1</b>	13.0	133.1	<b>5.59</b>	620.2	62.0	620.2	263.5
18	<b>729.5</b>	73.0	729.5	<b>133.1</b>	13.0	133.1	<b>5.48</b>	605.2	60.5	605.2	263.4
17	<b>714.8</b>	71.5	714.8	<b>133.1</b>	13.0	133.1	<b>5.37</b>	590.4	59.0	590.4	263.4
16	<b>700.2</b>	70.0	700.2	<b>133.2</b>	13.0	133.2	<b>5.26</b>	575.9	57.6	575.9	263.4
15	<b>686.0</b>	68.6	686.0	<b>133.2</b>	13.0	133.2	<b>5.15</b>	561.5	56.2	561.5	263.4
14	<b>671.9</b>	67.2	671.9	<b>133.3</b>	13.0	133.3	<b>5.04</b>	547.4	54.7	547.4	263.5
13	<b>658.0</b>	65.8	658.0	<b>133.3</b>	13.0	133.3	<b>4.94</b>	533.5	53.4	533.5	263.6
12	<b>644.4</b>	64.4	644.4	<b>133.4</b>	13.0	133.4	<b>4.83</b>	519.8	52.0	519.8	263.7
11	<b>631.0</b>	63.1	631.0	<b>133.5</b>	13.0	133.5	<b>4.73</b>	506.3	50.6	506.3	263.8
10	<b>617.8</b>	61.8	617.8	<b>133.5</b>	13.0	133.5	<b>4.63</b>	493.1	49.3	493.1	263.9
9	<b>604.8</b>	60.5	604.8	<b>133.6</b>	13.0	133.6	<b>4.53</b>	480.0	48.0	480.0	264.0
8	<b>592.0</b>	59.2	592.0	<b>133.7</b>	13.0	133.7	<b>4.43</b>	467.1	46.7	467.1	264.1
7	<b>579.4</b>	57.9	579.4	<b>133.7</b>	13.0	133.7	<b>4.33</b>	454.5	45.4	454.5	264.2
6	<b>567.0</b>	56.7	567.0	<b>133.8</b>	13.1	133.8	<b>4.24</b>	442.0	44.2	442.0	264.4
5	<b>554.8</b>	55.5	554.8	<b>133.9</b>	13.1	133.9	<b>4.14</b>	429.8	43.0	429.8	264.5
4	<b>542.8</b>	54.3	542.8	<b>133.9</b>	13.1	133.9	<b>4.05</b>	417.7	41.8	417.7	264.6
3	<b>531.0</b>	53.1	531.0	<b>134.0</b>	13.1	134.0	<b>3.96</b>	405.9	40.6	405.9	264.7
2	<b>519.4</b>	51.9	519.4	<b>134.0</b>	13.1	134.0	<b>3.88</b>	394.2	39.4	394.2	264.7
1	<b>507.9</b>	50.8	507.9	<b>134.0</b>	13.1	134.0	<b>3.79</b>	382.8	38.3	382.8	264.8
0	<b>496.7</b>	49.7	496.7	<b>134.0</b>	13.1	134.0	<b>3.71</b>	371.5	37.2	371.5	264.8
-1	<b>485.6</b>	48.6	485.6	<b>134.0</b>	13.1	134.0	<b>3.62</b>	360.5	36.0	360.5	264.8
-2	<b>474.7</b>	47.5	474.7	<b>134.0</b>	13.1	134.0	<b>3.54</b>	349.6	35.0	349.6	264.8
-3	<b>464.0</b>	46.4	464.0	<b>134.0</b>	13.1	134.0	<b>3.46</b>	338.9	33.9	338.9	264.7
-4	<b>453.5</b>	45.3	453.5	<b>133.9</b>	13.1	133.9	<b>3.39</b>	328.4	32.8	328.4	264.6
-5	<b>443.1</b>	44.3	443.1	<b>133.9</b>	13.1	133.9	<b>3.31</b>	318.1	31.8	318.1	264.5
-6	<b>432.9</b>	43.3	432.9	<b>133.8</b>	13.0	133.8	<b>3.24</b>	308.0	30.8	308.0	264.3
-7	<b>422.8</b>	42.3	422.8	<b>133.7</b>	13.0	133.7	<b>3.16</b>	298.0	29.8	298.0	264.1
-8	<b>412.9</b>	41.3	412.9	<b>133.5</b>	13.0	133.5	<b>3.09</b>	288.2	28.8	288.2	263.8
-9	<b>403.2</b>	40.3	403.2	<b>133.4</b>	13.0	133.4	<b>3.02</b>	278.7	27.9	278.7	263.4
-10	<b>393.6</b>	39.4	393.6	<b>133.2</b>	13.0	133.2	<b>2.96</b>	269.2	26.9	269.2	263.0
-11	<b>384.2</b>	38.4	384.2	<b>133.0</b>	13.0	133.0	<b>2.89</b>	260.0	26.0	260.0	262.6
-12	<b>374.9</b>	37.5	374.9	<b>132.7</b>	12.9	132.7	<b>2.82</b>	251.0	25.1	251.0	262.1
-13	<b>365.8</b>	36.6	365.8	<b>132.5</b>	12.9	132.5	<b>2.76</b>	242.1	24.2	242.1	261.5
-14	<b>356.8</b>	35.7	356.8	<b>132.2</b>	12.9	132.2	<b>2.70</b>	233.4	23.3	233.4	260.8
-15	<b>348.0</b>	34.8	348.0	<b>131.9</b>	12.9	131.9	<b>2.64</b>	224.8	22.5	224.8	260.1

-- pozor: pracovný rozsah nie je zohľadnený v tabuľke

Tv -VY		55										
Tz -VS [°C]	Qh nom [kW]	Qh min [kW]	Qh max [kW]	Pin nom [kW]	Pin min [kW]	Pin max [kW]	COP nom kW / kW	Qc nom [kW]	Qc min [kW]	Qc max [kW]	I nom [A]	
25	822.6	82.3	822.6	168.3	16.4	168.3	4.89	665.4	66.5	665.4	306.5	
24	807.5	80.8	807.5	168.4	16.4	168.4	4.79	650.2	65.0	650.2	306.4	
23	792.6	79.3	792.6	168.5	16.4	168.5	4.70	635.2	63.5	635.2	306.4	
22	777.9	77.8	777.9	168.6	16.5	168.6	4.61	620.4	62.0	620.4	306.4	
21	763.4	76.3	763.4	168.8	16.5	168.8	4.52	605.8	60.6	605.8	306.4	
20	749.0	74.9	749.0	168.9	16.5	168.9	4.44	591.3	59.1	591.3	306.5	
19	735.0	73.5	735.0	169.0	16.5	169.0	4.35	577.1	57.7	577.1	306.5	
18	721.1	72.1	721.1	169.1	16.5	169.1	4.26	563.1	56.3	563.1	306.6	
17	707.4	70.7	707.4	169.3	16.5	169.3	4.18	549.3	54.9	549.3	306.7	
16	693.9	69.4	693.9	169.4	16.5	169.4	4.10	535.7	53.6	535.7	306.8	
15	680.5	68.1	680.5	169.5	16.5	169.5	4.01	522.2	52.2	522.2	306.9	
14	667.4	66.7	667.4	169.6	16.5	169.6	3.93	509.0	50.9	509.0	307.0	
13	654.5	65.4	654.5	169.8	16.6	169.8	3.86	496.0	49.6	496.0	307.2	
12	641.7	64.2	641.7	169.9	16.6	169.9	3.78	483.1	48.3	483.1	307.3	
11	629.2	62.9	629.2	170.0	16.6	170.0	3.70	470.4	47.0	470.4	307.4	
10	616.8	61.7	616.8	170.1	16.6	170.1	3.63	458.0	45.8	458.0	307.5	
9	604.6	60.5	604.6	170.1	16.6	170.1	3.55	445.7	44.6	445.7	307.6	
8	592.5	59.3	592.5	170.2	16.6	170.2	3.48	433.6	43.4	433.6	307.6	
7	580.6	58.1	580.6	170.3	16.6	170.3	3.41	421.6	42.2	421.6	307.7	
6	568.9	56.9	568.9	170.3	16.6	170.3	3.34	409.9	41.0	409.9	307.7	
5	557.4	55.7	557.4	170.4	16.6	170.4	3.27	398.3	39.8	398.3	307.7	
4	546.0	54.6	546.0	170.4	16.6	170.4	3.20	386.9	38.7	386.9	307.7	
3	534.8	53.5	534.8	170.4	16.6	170.4	3.14	375.7	37.6	375.7	307.6	
2	523.7	52.4	523.7	170.3	16.6	170.3	3.07	364.6	36.5	364.6	307.5	
1	512.8	51.3	512.8	170.3	16.6	170.3	3.01	353.8	35.4	353.8	307.4	
0	502.0	50.2	502.0	170.2	16.6	170.2	2.95	343.1	34.3	343.1	307.2	
-1	491.4	49.1	491.4	170.1	16.6	170.1	2.89	332.5	33.3	332.5	307.0	
-2	480.9	48.1	480.9	170.0	16.6	170.0	2.83	322.2	32.2	322.2	306.7	
-3	470.6	47.1	470.6	169.9	16.6	169.9	2.77	312.0	31.2	312.0	306.4	
-4	460.4	46.0	460.4	169.7	16.6	169.7	2.71	301.9	30.2	301.9	306.0	
-5	450.3	45.0	450.3	169.5	16.5	169.5	2.66	292.1	29.2	292.1	305.6	
-6	440.4	44.0	440.4	169.3	16.5	169.3	2.60	282.3	28.2	282.3	305.1	
-7	430.6	43.1	430.6	169.0	16.5	169.0	2.55	272.8	27.3	272.8	304.5	
-8	420.9	42.1	420.9	168.7	16.5	168.7	2.50	263.4	26.3	263.4	303.8	
-9	411.4	41.1	411.4	168.4	16.4	168.4	2.44	254.2	25.4	254.2	303.1	
-10	401.9	40.2	401.9	168.0	16.4	168.0	2.39	245.1	24.5	245.1	302.3	
-11	392.6	39.3	392.6	167.6	16.3	167.6	2.34	236.1	23.6	236.1	301.4	
-12	383.4	38.3	383.4	167.1	16.3	167.1	2.29	227.4	22.7	227.4	300.5	
-13	374.4	37.4	374.4	166.6	16.3	166.6	2.25	218.7	21.9	218.7	299.4	
-14	365.4	36.5	365.4	166.1	16.2	166.1	2.20	210.3	21.0	210.3	298.3	
-15	356.5	35.7	356.5	165.5	16.1	165.5	2.15	201.9	20.2	201.9	297.1	

-- pozor: pracovný rozsah nie je zohľadnený v tabuľke

Tv -VY	65 (T-max)										
[°C]	Qh nom [kW]	Qh min [kW]	Qh max [kW]	Pin nom [kW]	Pin min [kW]	Pin max [kW]	COP nom kW / kW	Qc nom [kW]	Qc min [kW]	Qc max [kW]	I nom [A]
25	<b>811.1</b>	81.1	811.1	<b>214.5</b>	20.9	214.5	<b>3.78</b>	610.8	61.1	610.8	359.7
24	<b>797.1</b>	79.7	797.1	<b>214.7</b>	20.9	214.7	<b>3.71</b>	596.6	59.7	596.6	360.0
23	<b>783.2</b>	78.3	783.2	<b>214.8</b>	21.0	214.8	<b>3.65</b>	582.6	58.3	582.6	360.2
22	<b>769.6</b>	77.0	769.6	<b>215.0</b>	21.0	215.0	<b>3.58</b>	568.8	56.9	568.8	360.5
21	<b>756.1</b>	75.6	756.1	<b>215.2</b>	21.0	215.2	<b>3.51</b>	555.2	55.5	555.2	360.8
20	<b>742.8</b>	74.3	742.8	<b>215.3</b>	21.0	215.3	<b>3.45</b>	541.7	54.2	541.7	361.1
19	<b>729.7</b>	73.0	729.7	<b>215.5</b>	21.0	215.5	<b>3.39</b>	528.5	52.8	528.5	361.4
18	<b>716.7</b>	71.7	716.7	<b>215.6</b>	21.0	215.6	<b>3.32</b>	515.4	51.5	515.4	361.7
17	<b>703.9</b>	70.4	703.9	<b>215.8</b>	21.0	215.8	<b>3.26</b>	502.5	50.2	502.5	362.0
16	<b>691.3</b>	69.1	691.3	<b>215.9</b>	21.1	215.9	<b>3.20</b>	489.7	49.0	489.7	362.2
15	<b>678.8</b>	67.9	678.8	<b>216.0</b>	21.1	216.0	<b>3.14</b>	477.1	47.7	477.1	362.5
14	<b>666.5</b>	66.7	666.5	<b>216.1</b>	21.1	216.1	<b>3.08</b>	464.7	46.5	464.7	362.8
13	<b>654.4</b>	65.4	654.4	<b>216.2</b>	21.1	216.2	<b>3.03</b>	452.5	45.3	452.5	363.0
12	<b>642.4</b>	64.2	642.4	<b>216.3</b>	21.1	216.3	<b>2.97</b>	440.4	44.0	440.4	363.2
11	<b>630.5</b>	63.1	630.5	<b>216.3</b>	21.1	216.3	<b>2.92</b>	428.5	42.9	428.5	363.4
10	<b>618.8</b>	61.9	618.8	<b>216.3</b>	21.1	216.3	<b>2.86</b>	416.8	41.7	416.8	363.6
9	<b>607.3</b>	60.7	607.3	<b>216.3</b>	21.1	216.3	<b>2.81</b>	405.2	40.5	405.2	363.7
8	<b>595.8</b>	59.6	595.8	<b>216.3</b>	21.1	216.3	<b>2.75</b>	393.8	39.4	393.8	363.8
7	<b>584.6</b>	58.5	584.6	<b>216.3</b>	21.1	216.3	<b>2.70</b>	382.6	38.3	382.6	363.8
6	<b>573.4</b>	57.3	573.4	<b>216.2</b>	21.1	216.2	<b>2.65</b>	371.5	37.1	371.5	363.9
5	<b>562.4</b>	56.2	562.4	<b>216.2</b>	21.1	216.2	<b>2.60</b>	360.5	36.1	360.5	363.8
4	<b>551.5</b>	55.2	551.5	<b>216.0</b>	21.1	216.0	<b>2.55</b>	349.8	35.0	349.8	363.8
3	<b>540.7</b>	54.1	540.7	<b>215.9</b>	21.1	215.9	<b>2.50</b>	339.1	33.9	339.1	363.6
2	<b>530.1</b>	53.0	530.1	<b>215.7</b>	21.0	215.7	<b>2.46</b>	328.6	32.9	328.6	363.4
1	<b>519.6</b>	52.0	519.6	<b>215.5</b>	21.0	215.5	<b>2.41</b>	318.3	31.8	318.3	363.2
0	<b>509.2</b>	50.9	509.2	<b>215.3</b>	21.0	215.3	<b>2.37</b>	308.1	30.8	308.1	362.9
-1	<b>498.9</b>	49.9	498.9	<b>215.0</b>	21.0	215.0	<b>2.32</b>	298.1	29.8	298.1	362.5
-2	<b>488.7</b>	48.9	488.7	<b>214.7</b>	20.9	214.7	<b>2.28</b>	288.2	28.8	288.2	362.1
-3	<b>478.7</b>	47.9	478.7	<b>214.4</b>	20.9	214.4	<b>2.23</b>	278.5	27.8	278.5	361.6
-4	<b>468.7</b>	46.9	468.7	<b>214.0</b>	20.9	214.0	<b>2.19</b>	268.9	26.9	268.9	361.0
-5	<b>458.9</b>	45.9	458.9	<b>213.6</b>	20.8	213.6	<b>2.15</b>	259.4	25.9	259.4	360.3
-6	<b>449.1</b>	44.9	449.1	<b>213.1</b>	20.8	213.1	<b>2.11</b>	250.1	25.0	250.1	359.6
-7	<b>439.5</b>	43.9	439.5	<b>212.6</b>	20.7	212.6	<b>2.07</b>	240.9	24.1	240.9	358.8
-8	<b>429.9</b>	43.0	429.9	<b>212.1</b>	20.7	212.1	<b>2.03</b>	231.8	23.2	231.8	357.9
-9	<b>420.4</b>	42.0	420.4	<b>211.5</b>	20.6	211.5	<b>1.99</b>	222.9	22.3	222.9	356.9
-10	<b>411.1</b>	41.1	411.1	<b>210.9</b>	20.6	210.9	<b>1.95</b>	214.1	21.4	214.1	355.8
-11	<b>401.8</b>	40.2	401.8	<b>210.2</b>	20.5	210.2	<b>1.91</b>	205.5	20.5	205.5	354.6
-12	<b>392.6</b>	39.3	392.6	<b>209.4</b>	20.4	209.4	<b>1.87</b>	197.0	19.7	197.0	353.2
-13	<b>383.4</b>	38.3	383.4	<b>208.7</b>	20.4	208.7	<b>1.84</b>	188.6	18.9	188.6	351.8
-14	<b>374.4</b>	37.4	374.4	<b>207.8</b>	20.3	207.8	<b>1.80</b>	180.3	18.0	180.3	350.3
-15	<b>365.4</b>	36.5	365.4	<b>206.9</b>	20.2	206.9	<b>1.77</b>	172.2	17.2	172.2	348.7

-- pozor: pracovný rozsah nie je zohľadnený v tabuľke

# WAMAK TWW 600 EVI HeavyDuty 2L5

Tch -VY		W 12 / 7 °C										
[°C]	Qc nom [kW]	Qc min [kW]	Qc max [kW]	Pin nom [kW]	Pin min [kW]	Pin max [kW]	EER kW / kW	Qh nom [kW]	Qh min [kW]	Qh max [kW]	I nom [A]	
40	<b>352.0</b>	35.2	352.0	<b>145.0</b>	14.1	145.0	<b>2.43</b>	487.4	48.7	487.4	277.4	
39	<b>354.5</b>	35.5	354.5	<b>141.8</b>	13.8	141.8	<b>2.50</b>	486.9	48.7	486.9	273.7	
38	<b>357.0</b>	35.7	357.0	<b>138.6</b>	13.5	138.6	<b>2.58</b>	486.4	48.6	486.4	270.0	
37	<b>359.3</b>	35.9	359.3	<b>135.5</b>	13.2	135.5	<b>2.65</b>	485.9	48.6	485.9	266.5	
36	<b>361.6</b>	36.2	361.6	<b>132.5</b>	12.9	132.5	<b>2.73</b>	485.4	48.5	485.4	263.1	
35	<b>363.8</b>	36.4	363.8	<b>129.6</b>	12.6	129.6	<b>2.81</b>	484.9	48.5	484.9	259.8	
34	<b>366.0</b>	36.6	366.0	<b>126.8</b>	12.4	126.8	<b>2.89</b>	484.3	48.4	484.3	256.6	
33	<b>368.0</b>	36.8	368.0	<b>124.0</b>	12.1	124.0	<b>2.97</b>	483.8	48.4	483.8	253.4	
32	<b>370.1</b>	37.0	370.1	<b>121.3</b>	11.8	121.3	<b>3.05</b>	483.3	48.3	483.3	250.3	
31	<b>372.0</b>	37.2	372.0	<b>118.6</b>	11.6	118.6	<b>3.14</b>	482.8	48.3	482.8	247.3	
30	<b>373.9</b>	37.4	373.9	<b>116.0</b>	11.3	116.0	<b>3.22</b>	482.2	48.2	482.2	244.4	
29	<b>375.7</b>	37.6	375.7	<b>113.5</b>	11.1	113.5	<b>3.31</b>	481.7	48.2	481.7	241.6	
28	<b>377.5</b>	37.7	377.5	<b>111.0</b>	10.8	111.0	<b>3.40</b>	481.1	48.1	481.1	238.7	
27	<b>379.2</b>	37.9	379.2	<b>108.6</b>	10.6	108.6	<b>3.49</b>	480.5	48.1	480.5	236.0	
26	<b>380.8</b>	38.1	380.8	<b>106.2</b>	10.4	106.2	<b>3.59</b>	480.0	48.0	480.0	233.3	
25	<b>382.4</b>	38.2	382.4	<b>103.8</b>	10.1	103.8	<b>3.68</b>	479.3	47.9	479.3	230.6	
24	<b>383.9</b>	38.4	383.9	<b>101.5</b>	9.9	101.5	<b>3.78</b>	478.7	47.9	478.7	228.0	
23	<b>385.3</b>	38.5	385.3	<b>99.3</b>	9.7	99.3	<b>3.88</b>	478.1	47.8	478.1	225.4	
22	<b>386.7</b>	38.7	386.7	<b>97.1</b>	9.5	97.1	<b>3.98</b>	477.4	47.7	477.4	222.8	
21	<b>388.1</b>	38.8	388.1	<b>94.9</b>	9.3	94.9	<b>4.09</b>	476.7	47.7	476.7	220.3	
20	<b>389.3</b>	38.9	389.3	<b>92.8</b>	9.0	92.8	<b>4.20</b>	476.0	47.6	476.0	217.8	

Tc [°C]		W 23 / 18 °C										
[°C]	Qc nom [kW]	Qc min [kW]	Qc max [kW]	Pin nom [kW]	Pin min [kW]	Pin max [kW]	EER kW / kW	Qh nom [kW]	Qh min [kW]	Qh max [kW]	I nom [A]	
0												
40	<b>469.4</b>	46.9	469.4	<b>145.0</b>	14.1	145.0	<b>3.24</b>	604.5	60.4	605.0	277.1	
39	<b>472.5</b>	47.3	472.5	<b>141.8</b>	13.8	141.8	<b>3.33</b>	604.5	60.5	604.8	273.3	
38	<b>475.6</b>	47.6	475.6	<b>138.6</b>	13.5	138.6	<b>3.43</b>	604.6	60.5	604.7	269.5	
37	<b>478.5</b>	47.9	478.5	<b>135.5</b>	13.2	135.5	<b>3.53</b>	604.7	60.5	604.6	265.8	
36	<b>481.4</b>	48.1	481.4	<b>132.5</b>	12.9	132.5	<b>3.63</b>	604.8	60.5	604.5	262.2	
35	<b>484.3</b>	48.4	484.3	<b>129.6</b>	12.6	129.6	<b>3.74</b>	604.9	60.5	604.4	258.7	
34	<b>487.0</b>	48.7	487.0	<b>126.8</b>	12.4	126.8	<b>3.84</b>	605.1	60.5	604.4	255.3	
33	<b>489.7</b>	49.0	489.7	<b>124.0</b>	12.1	124.0	<b>3.95</b>	605.2	60.5	604.4	252.0	
32	<b>492.4</b>	49.2	492.4	<b>121.3</b>	11.8	121.3	<b>4.06</b>	605.3	60.5	604.4	248.7	
31	<b>494.9</b>	49.5	494.9	<b>118.6</b>	11.6	118.6	<b>4.17</b>	605.4	60.5	604.4	245.5	
30	<b>497.4</b>	49.7	497.4	<b>116.0</b>	11.3	116.0	<b>4.29</b>	605.6	60.6	604.5	242.3	
29	<b>499.9</b>	50.0	499.9	<b>113.5</b>	11.1	113.5	<b>4.41</b>	605.7	60.6	604.5	239.3	
28	<b>502.3</b>	50.2	502.3	<b>111.0</b>	10.8	111.0	<b>4.53</b>	605.8	60.6	604.6	236.2	
27	<b>504.6</b>	50.5	504.6	<b>108.6</b>	10.6	108.6	<b>4.65</b>	605.9	60.6	604.7	233.2	
26	<b>506.8</b>	50.7	506.8	<b>106.2</b>	10.4	106.2	<b>4.77</b>	606.1	60.6	604.8	230.3	
25	<b>509.0</b>	50.9	509.0	<b>103.8</b>	10.1	103.8	<b>4.90</b>	606.2	60.6	604.9	227.4	
24	<b>511.2</b>	51.1	511.2	<b>101.5</b>	9.9	101.5	<b>5.03</b>	606.3	60.6	605.1	224.5	
23	<b>513.3</b>	51.3	513.3	<b>99.3</b>	9.7	99.3	<b>5.17</b>	606.3	60.6	605.2	221.6	
22	<b>515.3</b>	51.5	515.3	<b>97.1</b>	9.5	97.1	<b>5.31</b>	606.4	60.6	605.3	218.8	
21	<b>517.2</b>	51.7	517.2	<b>94.9</b>	9.3	94.9	<b>5.45</b>	606.4	60.6	605.4	216.0	
20	<b>519.1</b>	51.9	519.1	<b>92.8</b>	9.0	92.8	<b>5.60</b>	606.5	60.6	605.6	213.2	

-- pozor: pracovný rozsah nie je zohľadnený v tabuľke

LEGENDA:

Tz-VS: Teplota zdroja - vstup [°C]

Tv-VY: Teplota vykurovania - výstup [°C]

Tch-VY: Teplota chladenia - výstup [°C]

Qh nom: Nominálny tepelný výkon

Qh min: Minimálny tepelný výkon

Qh max: Maxmálny tepelný výkon

Pin nom: Príkion pri nominálnom tepelnom výkone

Pin min: Príkion pri minimálnom tepelnom výkone

Pin max: Príkion pri maximálnom tepelnom výkone

COP nom: Koeficient účinnosti pri nominálnom tepelnom výkone

Qc nom: Chladiaci výkon / odobrané teplo pri nominálnom tepelnom výkone

Qc min: Chladiaci výkon / odobrané teplo pri minimálnom tepelnom výkone

Qc max: Chladiaci výkon / odobrané teplo pri maximálnom tepelnom výkone

I nom: Prúd pri nominálnom tepelnom výkone

EER: Koeficient účinnosti pri nominálnom chladiacom výkone



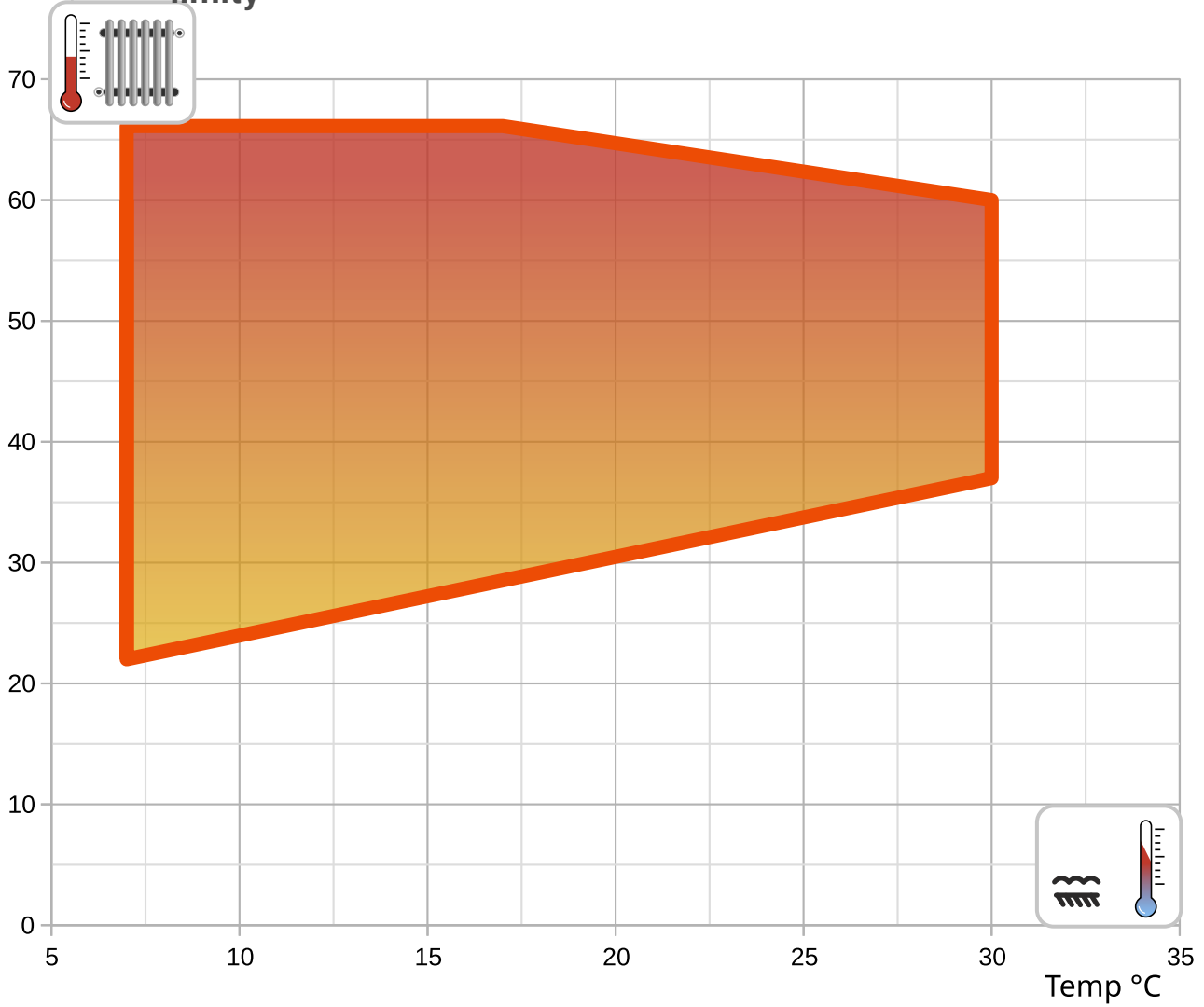

Prevádzkové  
Temp °C limity

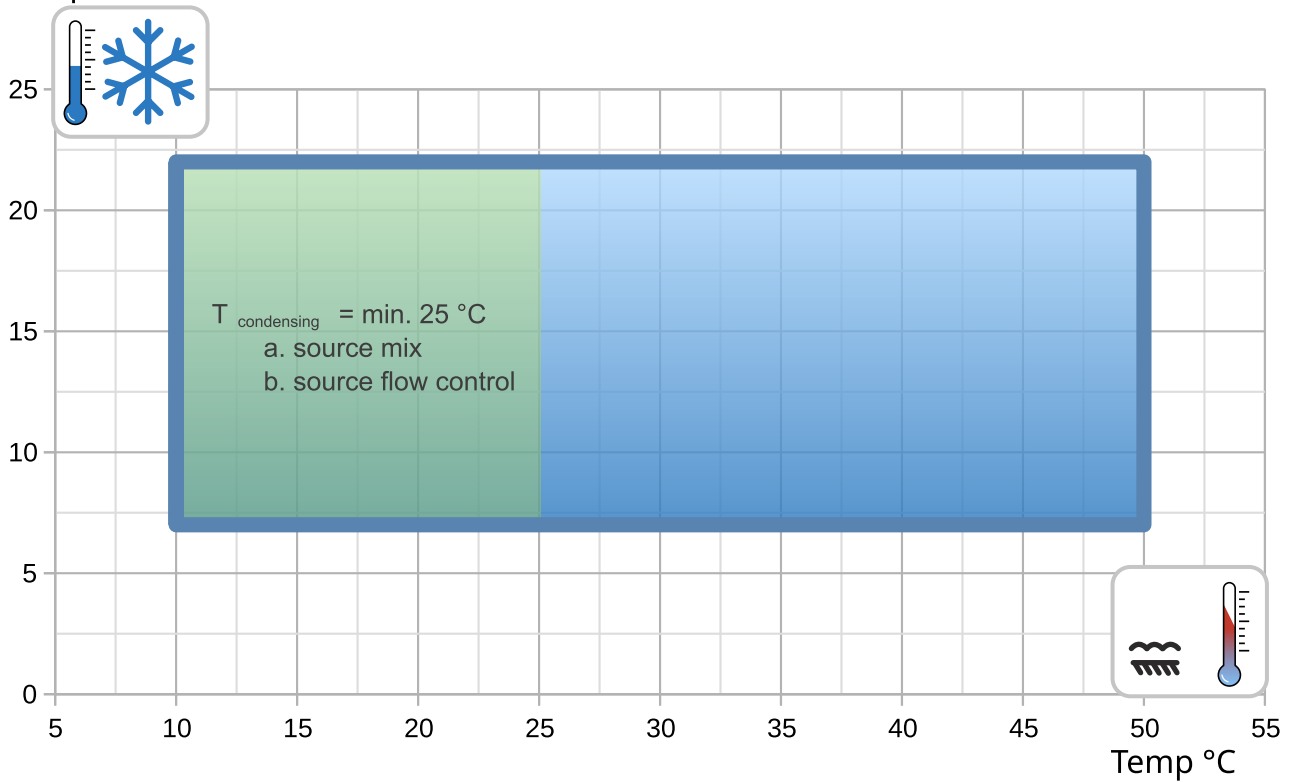

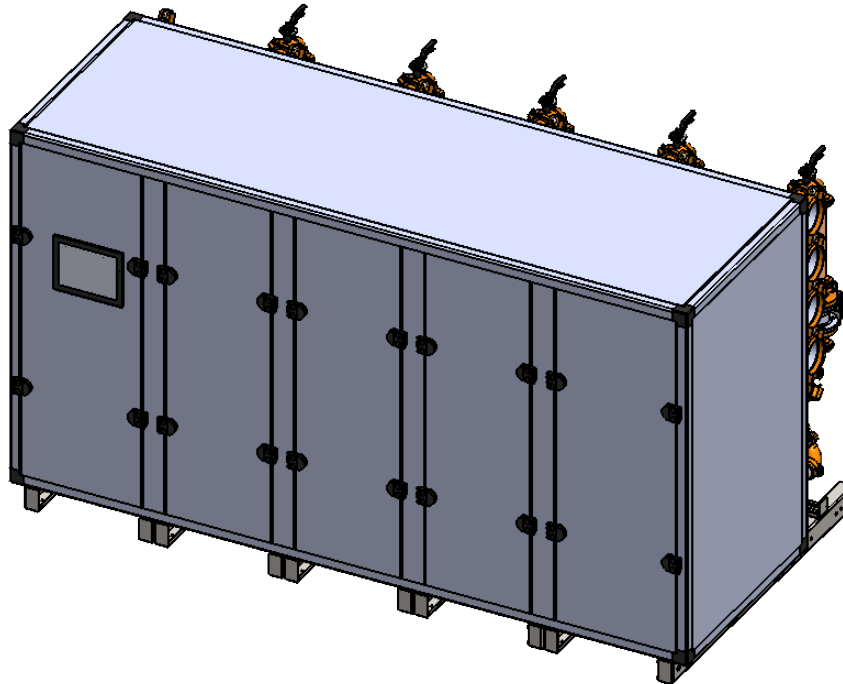
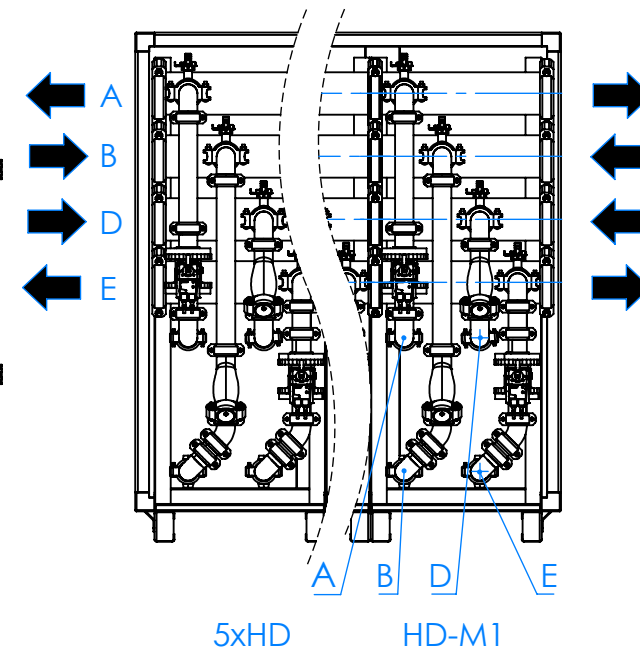
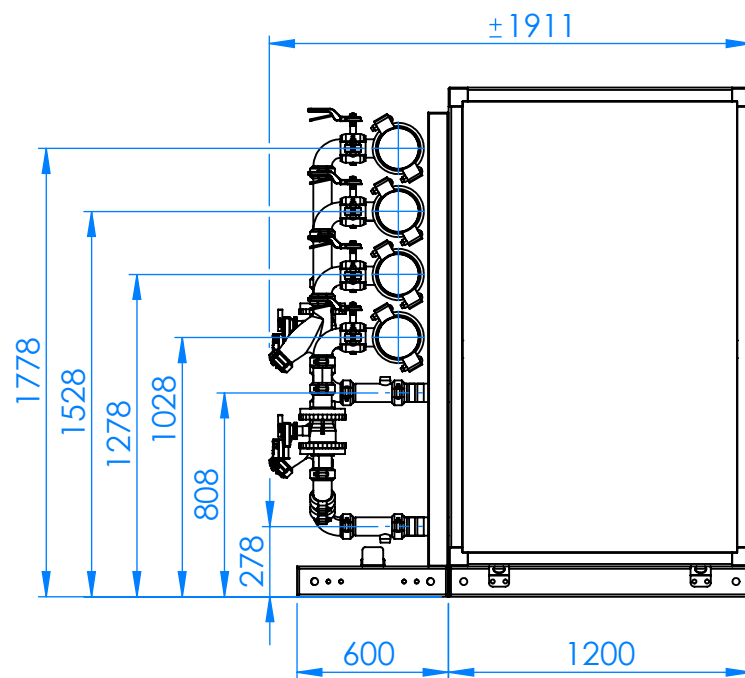
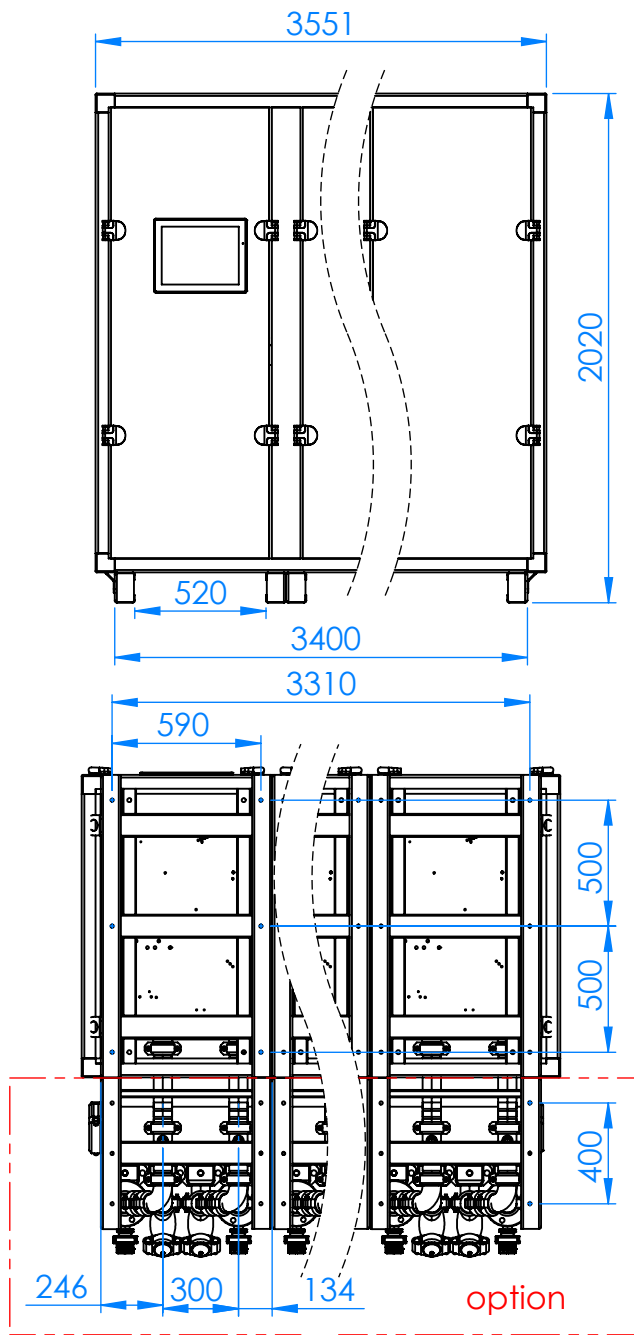
Temp °C





- A - 
- B - 
- D - 
- E - 

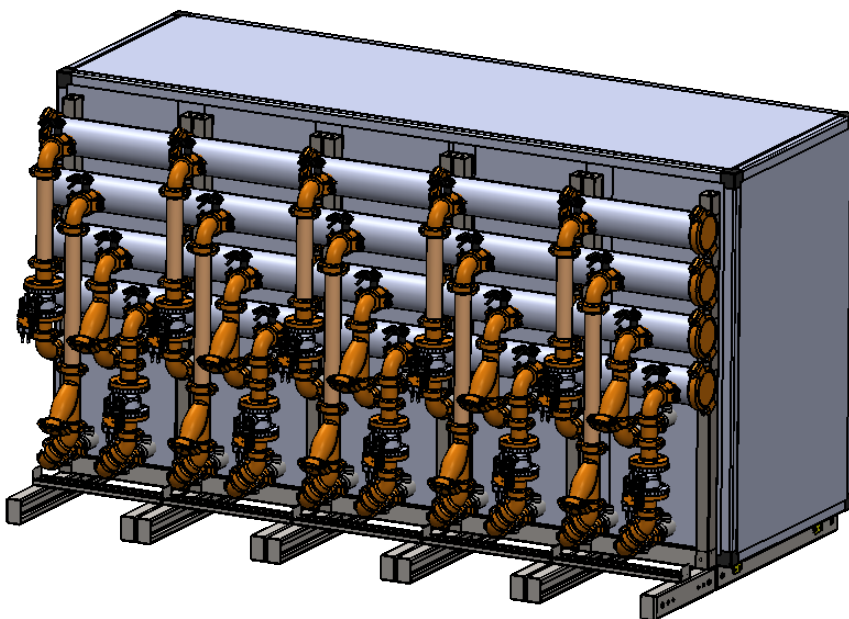
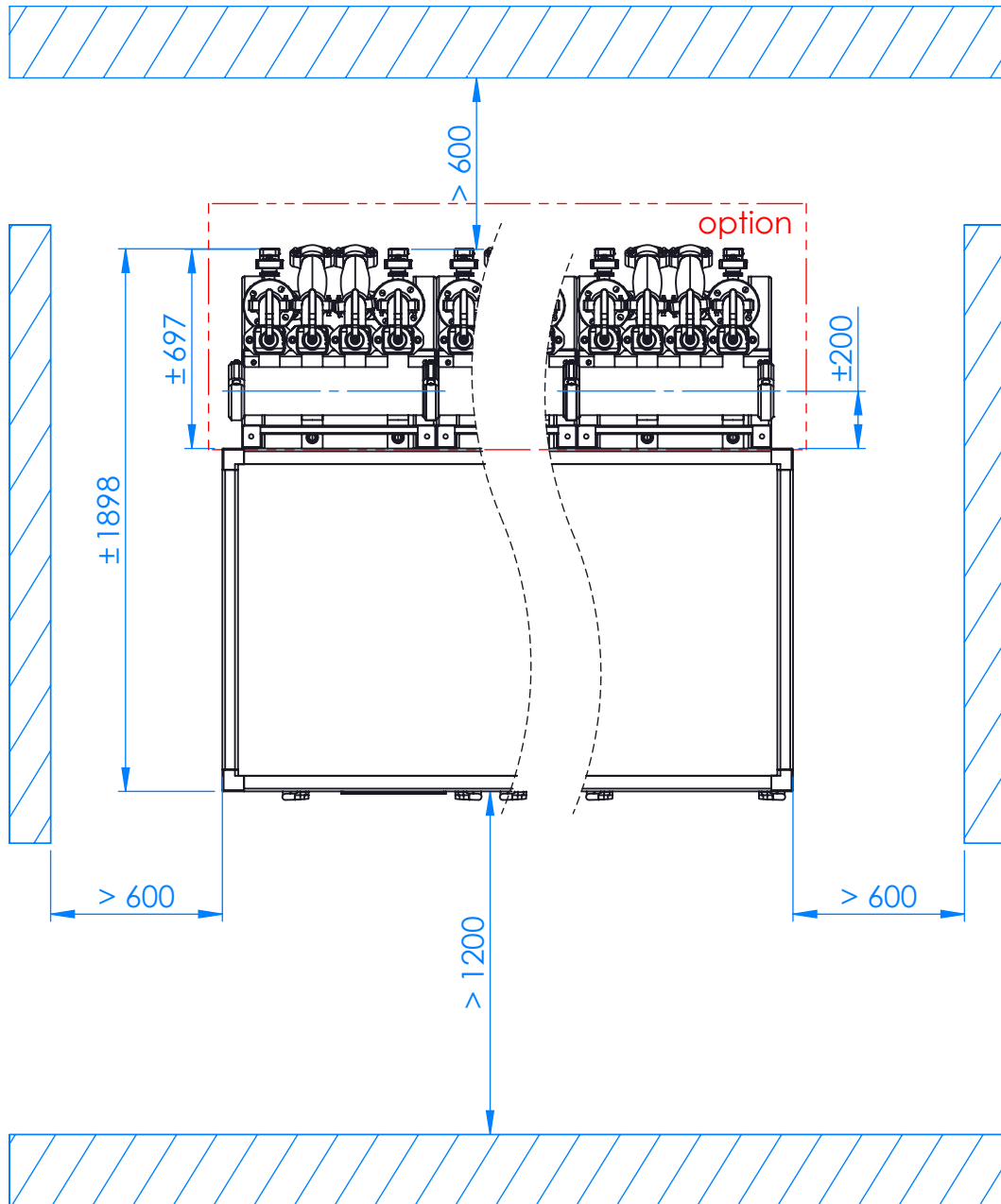

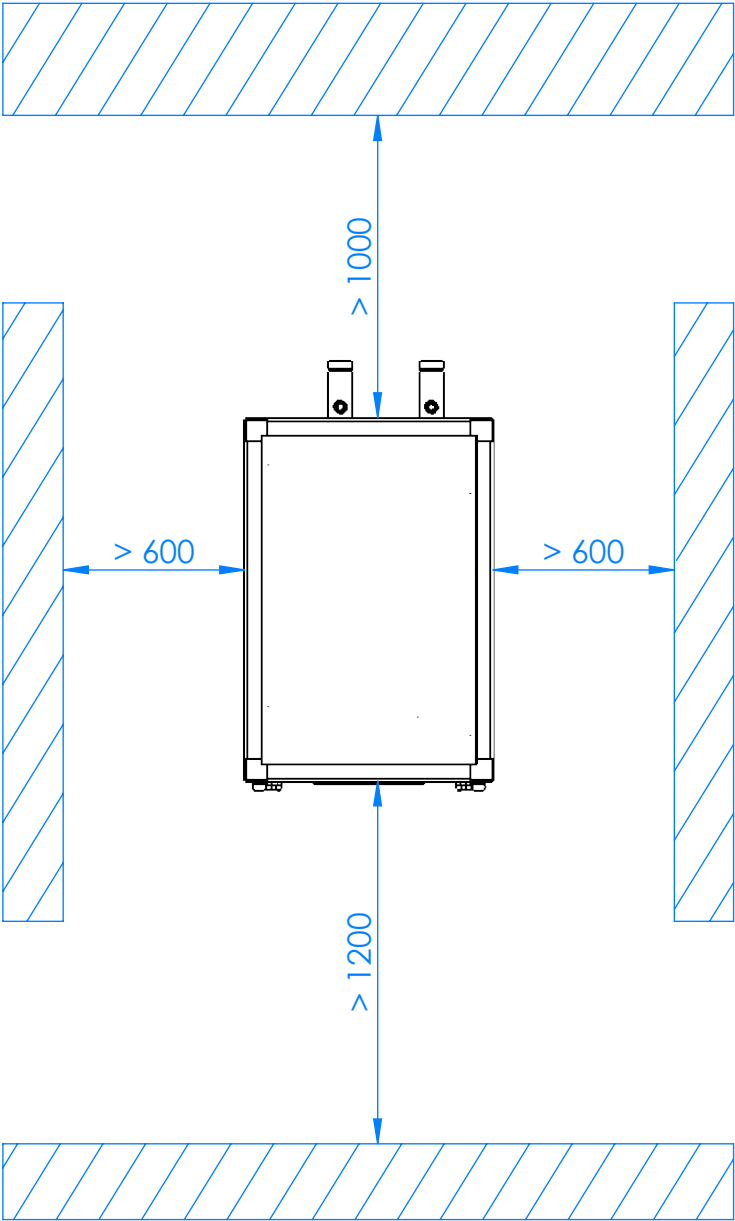

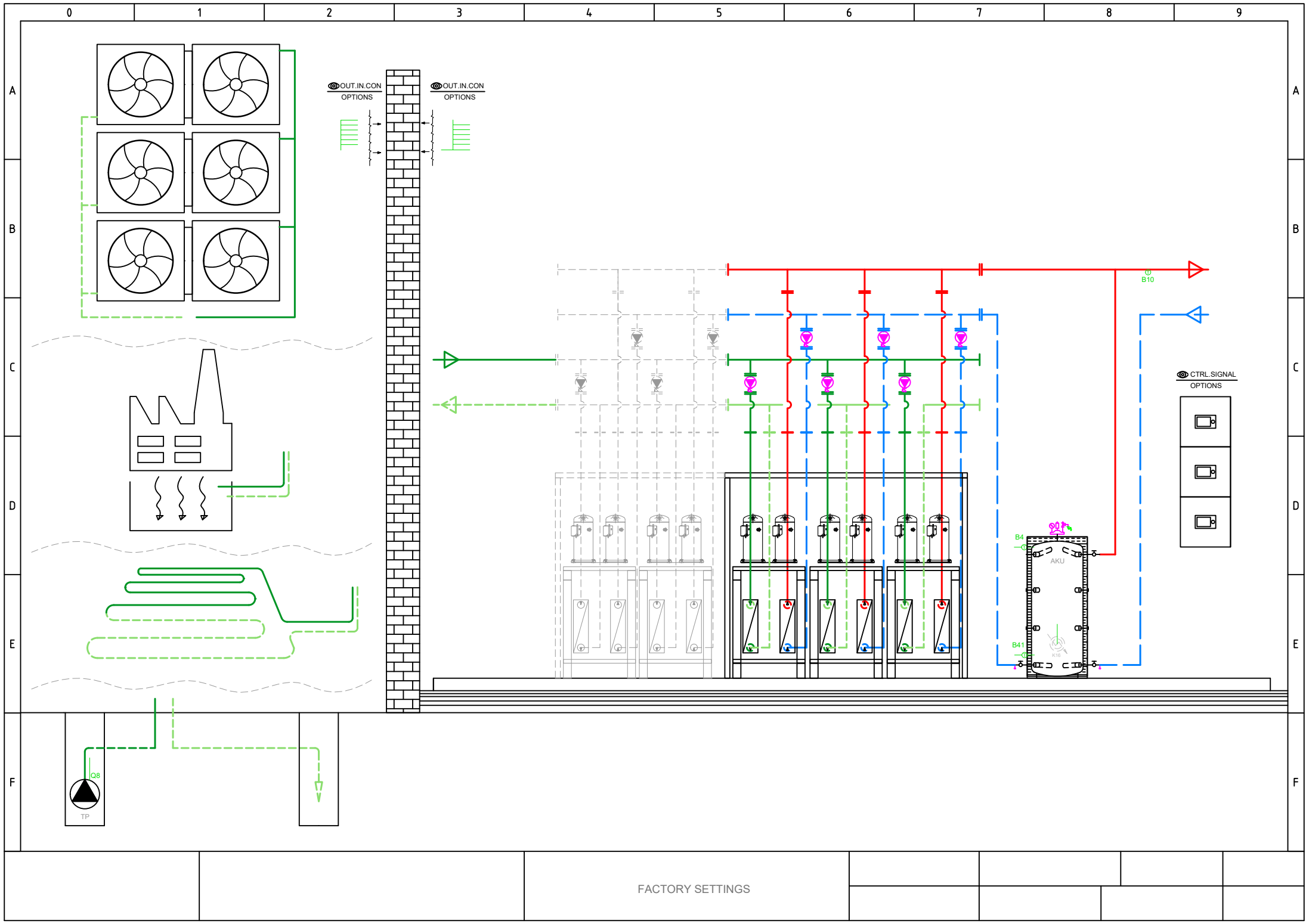

Total: max 6A  
1 x QX...: max 2A

Hlavné napájanie 230V / 50 Hz  
Uzemnenie  
Nulový vodič

E9	Spínač nízkeho tlaku E9
E10	Spínač vysokého tlaku E10
E15	Spínač prietoku zdroja E15
E24	Spínač prietoku spotreby E24
E6	Blokovanie vys. tarifa el. E6
E12	Preťaženie kompresora 2 E12
E21	Sled fáz E21
E22	Sled fáz E22
E23	Sled fáz E23
E11	Preťaženie kompresora E11
K1	Kompresor I. stupeň K1

Q8 Čerpadlo zdroja Q8

Q9 Čerpadlo kondenzátora Q9

K10 Alarmový výstup K10

K40 Ohrev oleja K40

K81 Ventil výparníka K81

K82 Ventil EVI K82

K2 Kompresor 2. stupeň K2

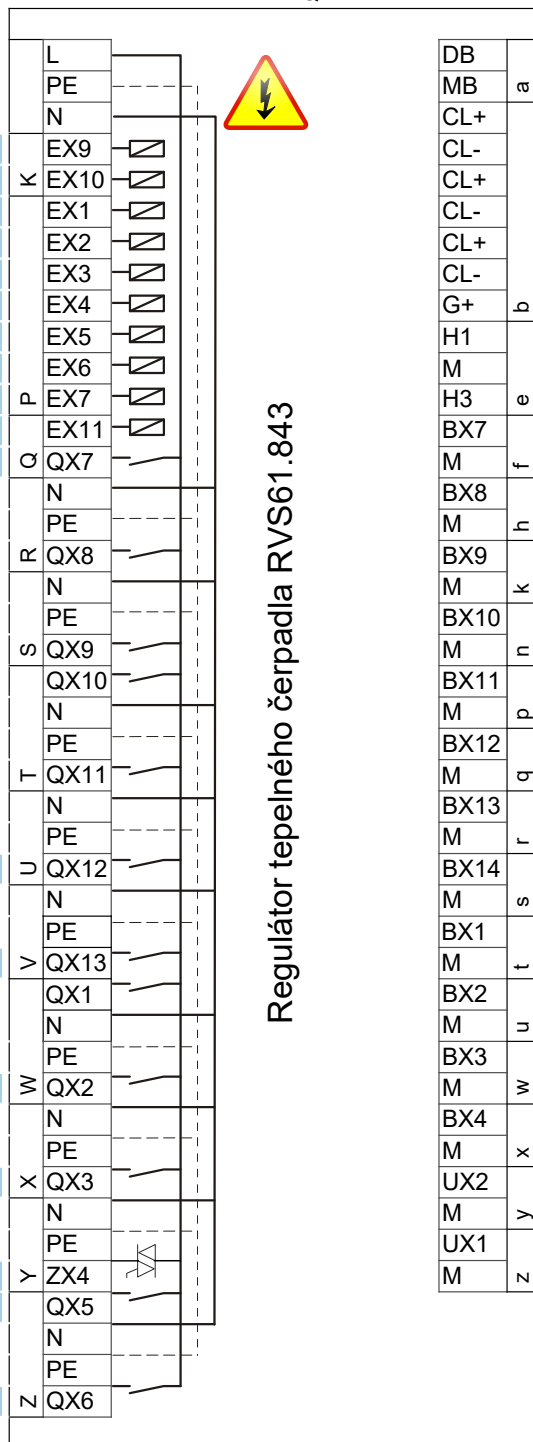

Regulátor tepelného čerpadla RVS61.843

DB	LPB Bus dáta
MB	LPB Bus zem
CL+	Izbový prístroj QAA...
CL-	Izbový prístroj QAA...
CL+	Izbový prístroj QAA... 2.
CL-	Izbový prístroj QAA... 2.
CL+	Izbový prístroj QAA... 3.
CL-	Izbový prístroj QAA... 3.
G+	12V napájanie → von
H1	
M	
H3	Požiadavka spotrebiča VK1
BX7	B81 Snímač horúcich plynov K1 B81
M	
BX8	
M	
BX9	
M	
BX10	B21 Snímač teploty výstupu TČ B21
M	
BX11	
M	
BX12	B71 Snímač teploty spiatocky TČ B71
M	
BX13	B91 Snímač vstupu zdroja B91
M	
BX14	B84 Snímač výstupu zdroja B92/B84
M	
BX1	
M	
BX2	
M	
BX3	B83 Snímač chladiaceho média B83
M	
BX4	B82 Snímač horúcich plynov K2 B82
M	
UX2	Čerpadlo kondenzátora Q9
M	0..10V analógový signál
UX1	Čerpadlo zdroja Q8
M	0..10V analógový signál

- AVS75.390
- AVS75.391
- AVS75.370

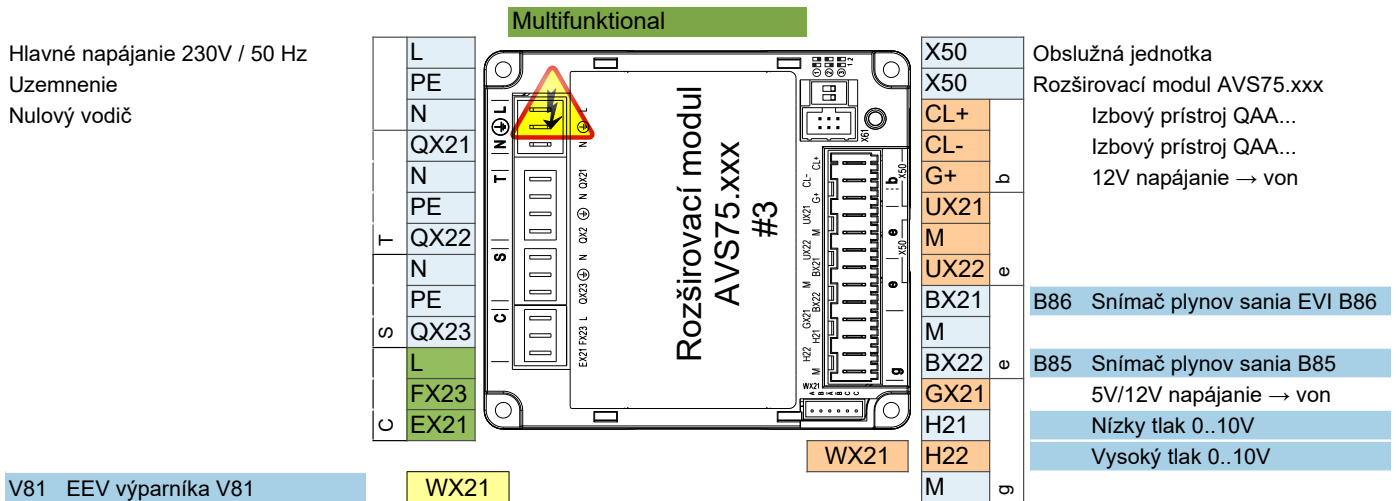
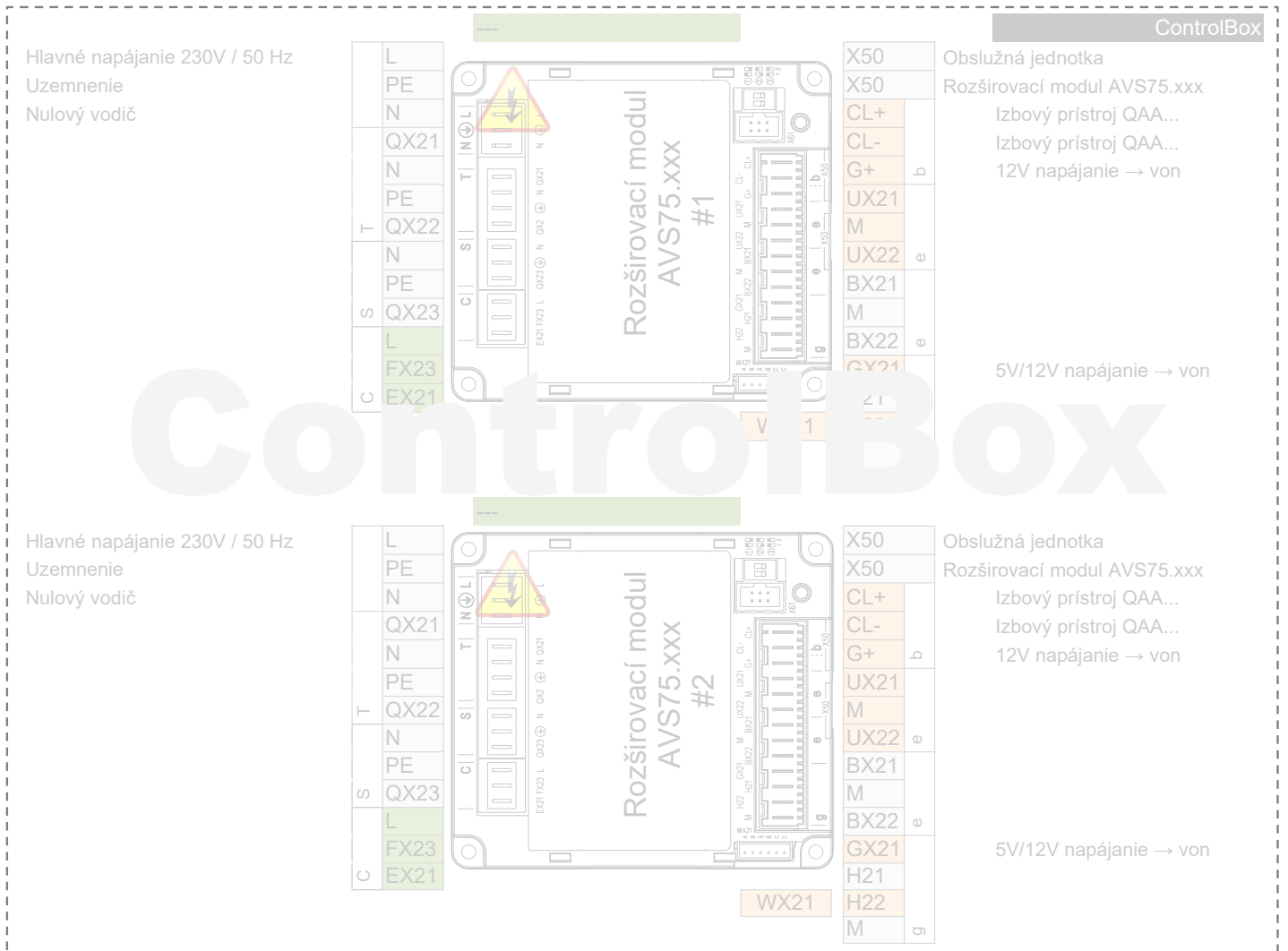

HEAT PUMP

EXTERNAL  
INTERNAL



K1

K2

K82

K81

K40

K10

Q8 UX1

Q9 UX2

E11  
KRW1  
F1K  
E11

E12  
KRW2  
F2K  
E12

E6

Q9 ERR  
F1S  
E24

Q8.ERR  
F1Z  
E15

E10  
E9

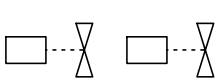

230V,50Hz max 6A

0...10V



DO



230V,50Hz max 6A



0...10V



DO



DO



DO



DO



DO



DO



DO



DO



DO



DO



DO



DO



DO



DO



DO



DO



DO



DO



DO



DO



DO

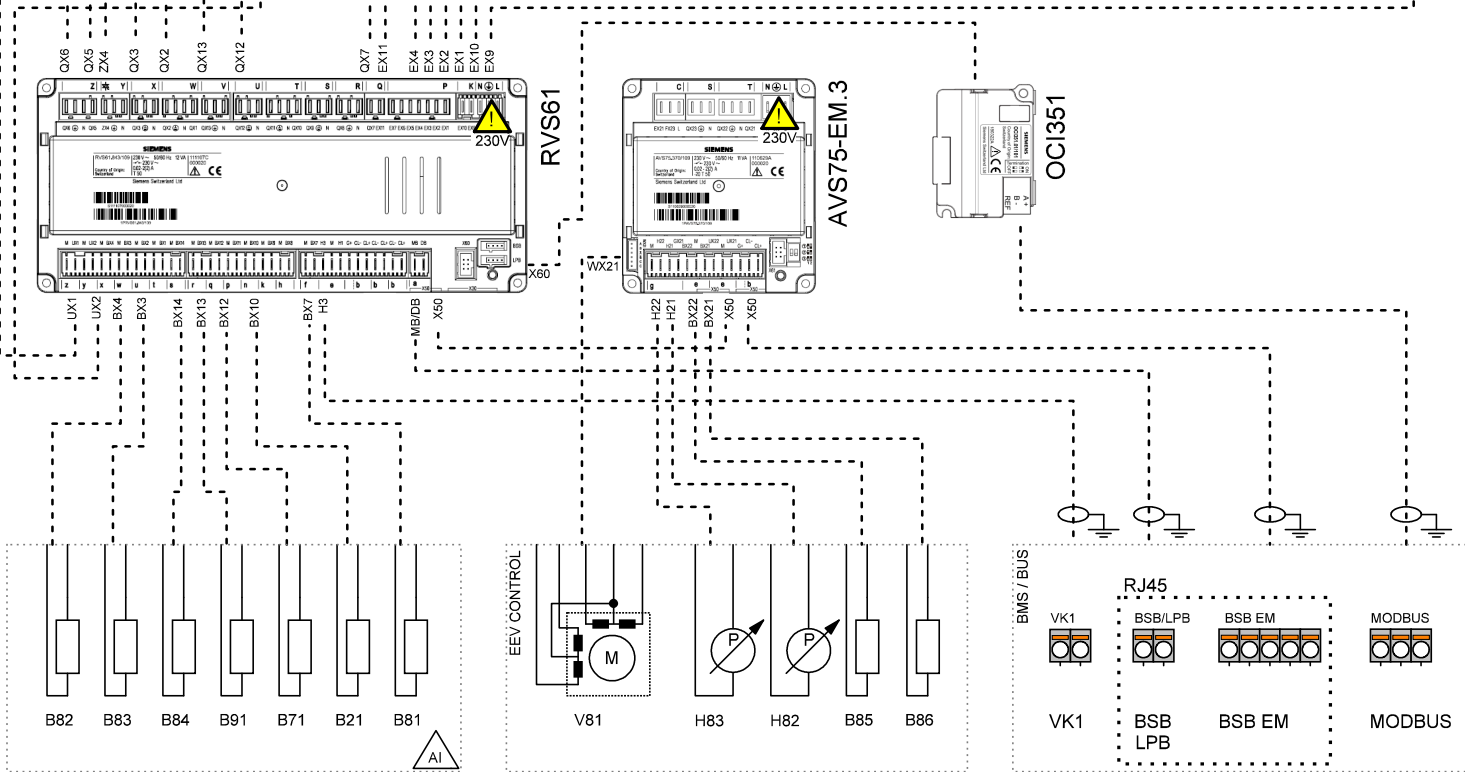
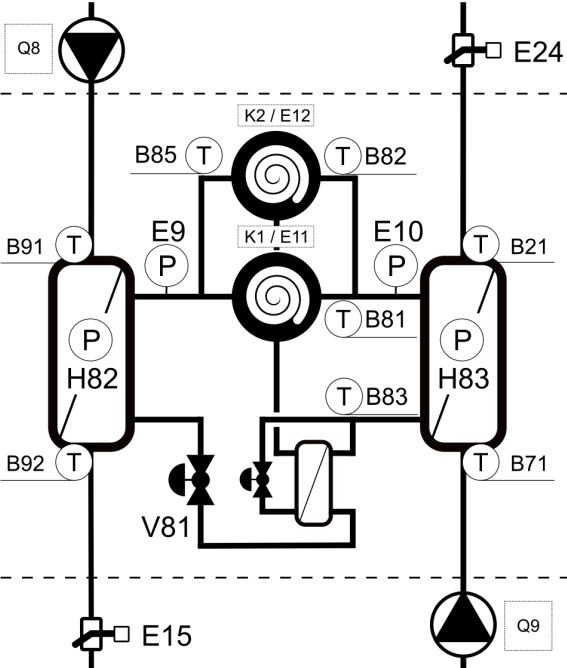

PWR SPLY: ..... 3~ 400V, 50 Hz  
CTRL: ..... 1~ 230V, 50 HZ

Company	Title	Version / Note	Number	Created by	Date	Page
	TBW-TWW	05/2024				1

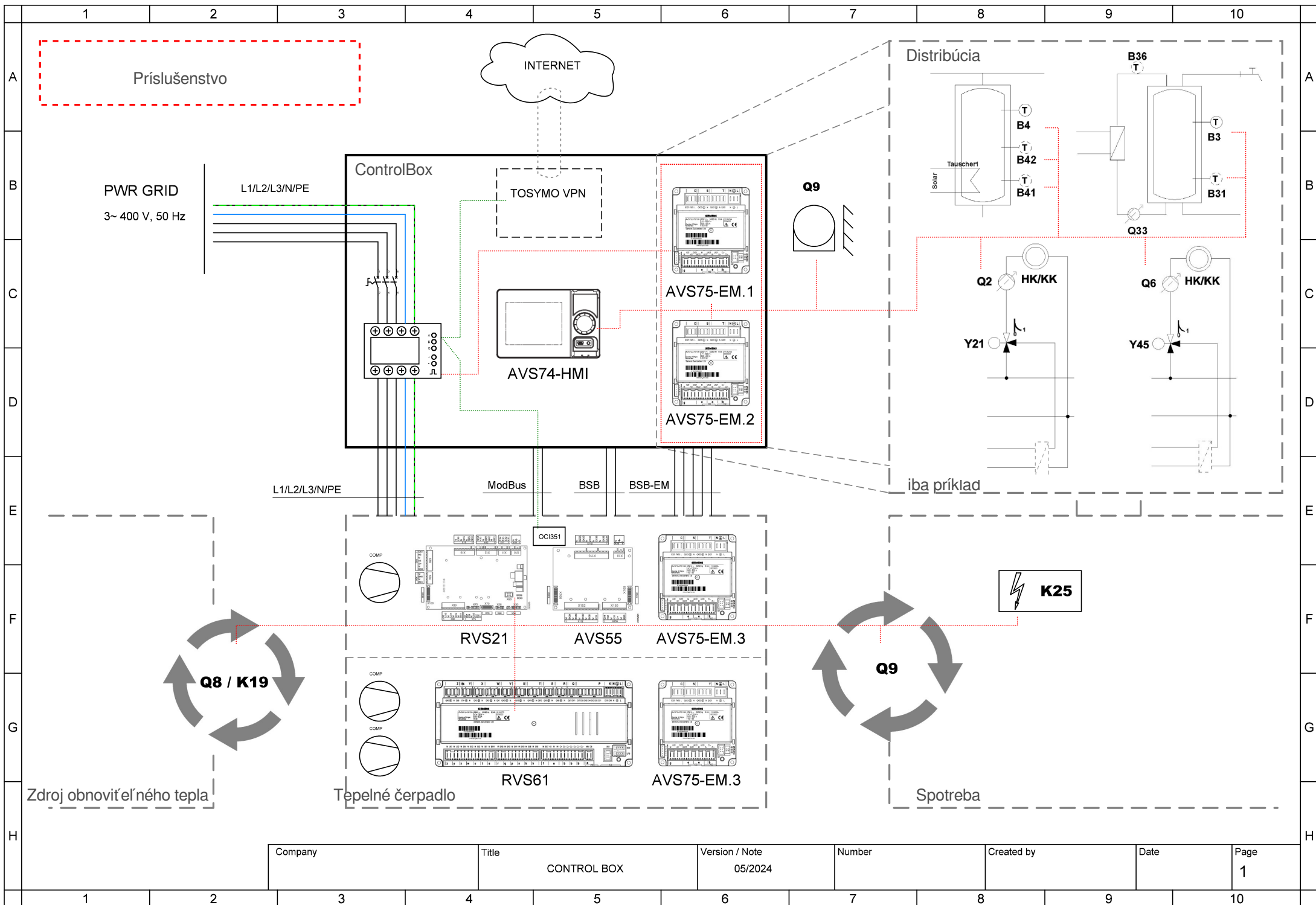

Company	Title	Version / Note	Number	Created by	Date	Page
	CONTROL BOX	05/2024				1



Company	Title	Version / Note	Number	Created by	Date	Page
	CONTROL BOX	05/2024				2





Company	Title	Version / Note	Number	Created by	Date	Page
	CONTROL BOX	05/2024				4



- AVS75.390
- AVS75.391
- AVS75.370

- AVS75.370**  
 Hlavné napájanie 230V / 50 Hz  
 Uzemnenie  
 Nulový vodič
- Y1** Zmiešavací ventil otváranie
  - Y2** Zmiešavací ventil zatvárať
  - Q2** Čerpadlo vyk. okruhu 1 Q2
  - L** Fáza 230V
  - E61** Smart Grid E61

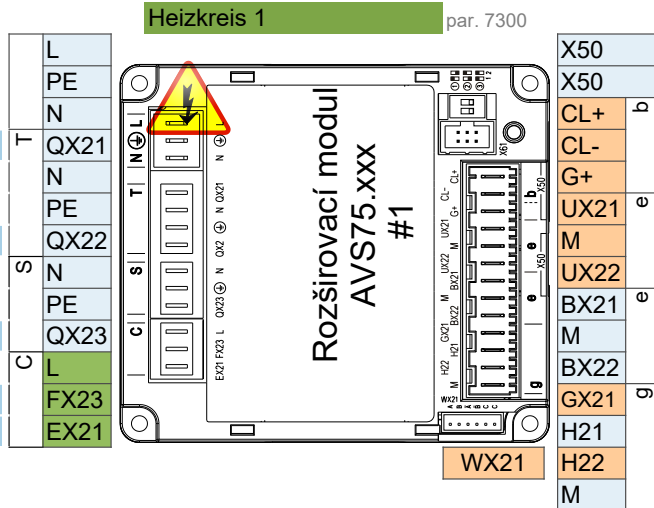

Rozšiřovací modul AVS75.xxx  
 Izbový prístroj QAA...  
 Izbový prístroj QAA...

**B1** Snímač prietoku 1

Čítanie pulzov

- AVS75.370**  
 Hlavné napájanie 230V / 50 Hz  
 Uzemnenie  
 Nulový vodič
- Q3** Servopohon TUV Q3
  - K6** El. výhrevná vložka TUV K6
  - Q6** Čerpadlo vyk. okruhu 2 Q6
  - L** Fáza 230V
  - E62** Smart Grid E62

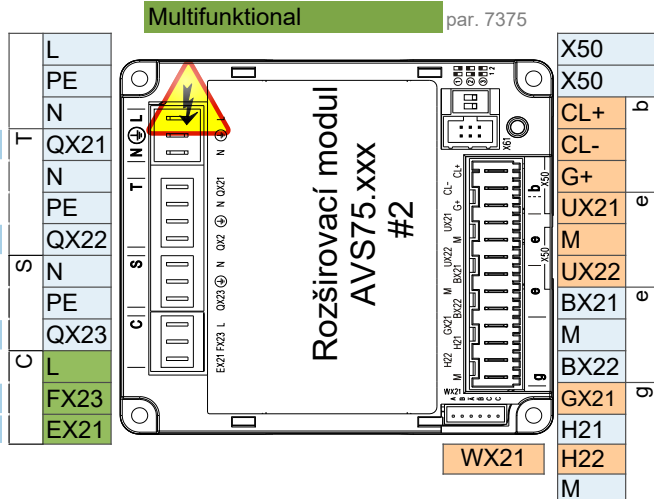

Obslužná jednotka  
 Rozšiřovací modul AVS75.xxx  
 Izbový prístroj QAA...  
 Izbový prístroj QAA...

**B3** Snímač TUV B3

**B4** Snímač AKU zásobníka B4

- Hlavné napájanie 230V / 50 Hz  
 Uzemnenie  
 Nulový vodič

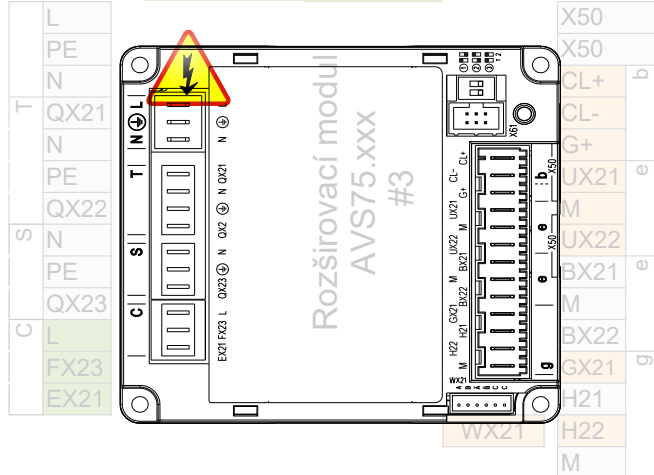

Obslužná jednotka  
 Rozšiřovací modul AVS75.xxx  
 Izbový prístroj QAA...  
 Izbový prístroj QAA...

Pozor: Rozšiřovací modul 3 je v tepelnom čerpadle

### 1 ControlBox

---

ControlBox s dvoma zabudovanými rozširujúcimi modulmi umožňuje početné možnosti ovládania aplikácie na strane spotrebiča za tepelným čerpadlom. Viac informácií nájdete v schéme ControlBoxu a v hárku s aplikačnými schémami.

### 2 Fixná žiadaná teplota výstupu - Zap / Vyp bezpotenciálny kontakt

---

2-vodičový tienový kábel 2 x 0,5 mm<sup>2</sup> - Nastavená hodnota = 45 °C (upraviteľné parametrom 1859)

Pripojovacia svorka - pozri schému zapojenia

### 3 Analógová regulácia žiadanej teploty výstupu 0..10V

---

2-vodičový tienový kábel 2 x 0,5 mm<sup>2</sup> - Nastavená hodnota: 0V = 16°C ~ 10V = 60°C (možnosť úpravy v nastavení parametrov)

Pripojovacia svorka - pozri schému zapojenia

### 4 ModBus RTU komunikačný príkaz

---

3 žilový tienový kábel min. 3 x 0,25 mm<sup>2</sup>

Pre tabuľku mapovania ModBus kontaktujte technickú podporu

### 5 MQTT IoT komunikačný protokol

---

Pre viac informácií kontaktujte technickú podporu