

Grundlegende Leistungsdaten - WAMAK TWW 220 WHR HeavyDuty 2L2

Heizen - EN 14511		
Wärmeleistung [kW]	W10 / W35 (max)	121.4 (30.4 / 121.4)
	W10 / W35 (min)	30.4 (30.4 / 121.4)
	W10 / W34	122.2 (30.5 / 122.2)
Leistungsaufnahme [kW]	W10 / W35 (max)	20.6 (5.0 / 20.6)
	W10 / W35 (min)	5.0 (5.0 / 20.6)
	W10 / W34	20.2 (4.9 / 20.2)
Leistungszahl Heizen [COP]	W10 / W35 (max)	5.89
	W10 / W35 (min)	6.05
	W10 / W34	6.04
Jahreszeitbedingte Raumheizungs-Energieeffizienz - SCOP EN 14825		
Klimazone Durchschnitt / Niedrigtemp. [35°C]	SCOP	6.74
	η [%]	269.8
	Label	A+++
	Qhe [kWh]	36839.5
	Pdesignh [kW]	121.4
	Tbivalent [°C]	-7
Kühlung		
Kühlleistung - [kW]	A35 / W23-18	91.9
	A25 / W23-18	103.4
	A35 / W12-7	59.9
	A25 / W12-7	59.9
Jahreszeitbedingte Raumkühlungs-Energieeffizienz - SEER EN 14825		
[W 23 / 18°C]	SEER	5.39
	Qce [kWh]	35940.0
	η_c [%]	215.5
Schall EN 12102		
Schalleistungspegel - Lw	dB(A)	67.2
Schalldruckpegel - Lp	1 m dB(A)	59.2
	5 m dB(A)	45.2
	10 m dB(A)	39.2
Mechanische und Betriebs-Informationen		
Verdichterbauart (3~ 400/50)	SCROLL / 4 /	Ein/Aus
Kältemittel	R513A (GWP - 631)	2 x 11.2 kg
Einsatzgrenze Heizungswasser - (min / max) [°C]		45 / 85
Einsatzgrenze Wärmequelle - (min / max) [°C]		-10 / 50
Gewicht		1240 kg

Wichtigste technische Daten - WAMAK TWW 220 WHR HeavyDuty 2L2

Gehäuse Bezeichnung		HD2L2		Daten von Wärmeabgabe		
Grundlegende Abmessungen	Hohe [mm]	2000		Einsatzgrenze	MAX [°C]	85
	Breite [mm]	1500		Heizungswasser	MIN [°C]	45
	Länge [mm]	1200		genauer siehe Betriebsgrenzendiagramm		
Gewicht [kg]	1240		Kondensator	Anschlussdimension	2 x VIC 2.1/2 "	
Gehäuse Farbe	Grau			Bauart	BPHE	
Gehäuse IP Klasse	IP20			Anzahl	2	
				Material	AISI 316	
Kältekreis						
Verdichter	Bauart	Scroll		Maximaler Überdruck - Kältemittel [bar]		
	Leistungstufen	4		Maximaler Überdruck - Wasser [bar]		
	Ein/Aus			Prüfdruck [bar]		
	Leistungsfaktor Cosφ	0.63		Wärmeträger		
	Wicklungswiderstand	1.23 Ohm		Volumenstrom @ dT 5K (nom) - Wasser [m3/h]		
Kältemittel		R513A		Interne Druckdifferenz - Wasser [kPa]		
	Menge	2 x 11.2 kg		Temperaturdifferenz	@ 35°C (nom)	5 K
	GWP	631			@ 55°C	8 K
	Sicherheitsklasse	A1			@ 65°C	10 K
Kältemittelöl	POE RL32-3MAF			Daten von Erneuerbarer Energiequelle		
	Ölmenge	4 x 3.38 L		Einsatzgrenze	MIN [°C]	-10
Maximaler Hochdruck - Kältemittel [bar]		32		Wärmequelle	MAX [°C]	50
	PED Klasse	2		genauer siehe Betriebsgrenzendiagramm		
EVI - Dampfeinspritzung mit Economiser			Verdampfer	Anschlussdimension	2 x VIC 2.1/2 "	
				Bauart	BPHE	
				Anzahl	2	
				Material	AISI 316	
			Maximaler Überdruck - Kältemittel [bar]			
			Wärmeträger			
			Maximaler Überdruck - Wasser [bar]			
			Volumenstrom - Wasser [m3/h]			
			Interne Druckdifferenz - Wasser [kPa]			
			Temperaturdifferenz - Wasser			
Daten von Elektroanschluss						
Einspeisung [#~ V/Hz]		3~ 400/50				
Strom	Nominal [A]	68.88				
	Maximal [A]	89.20				
	Start [A]	12.9				
Sanftanlasser		-				
Hauptsicherung		C100				
Steuerungssystem						
Hauptregler	SIEMENS	RVS 61				
Erweiterungsmo dul	AVS75.3xx	AVS75.3xx	AVS75.372			
Bus Clip-In			Modbus OCI353			
Online-Verbindung	Web server OZW672		ToSyMo			
EEV Regelung			SEC61			

*** mit Zubehör

WAMAK TWW 220 WHR HeavyDuty 2L2

ErP (EU) No 811/2013: Technische Parameter für Wärmepumpen-Raumheizgeräte

Modell	TWW 220 WHR HeavyDuty 2L2
Luft-Wasser-Wärmepumpe	nein
Sole/Wasser-Wärmepumpe	nein
Wasser/Wasser-Wärmepumpe	ja
Niedertemperatur-Wärmepumpe	nein
Ausgestattet mit einer Zusatzheizung	nein
Wärmepumpen-Kombi-Heizgerät	nein
Temperaturanwendung	niedrig (35 °C - 30 °C)
Klimaverhältnisse	durchschnittlich

Angabe	Symbol	Wert	Ein.	Angabe	Symbol	Wert	Ein.
Nennwärmeleistung bei Tdesignh	Prated	121.4	kW	Jahreszeitbedingte Raumheizungs-Energieeffizienz	η_s	269.8	%
Ausgewiesene Heizleistung für Teillast bei einer Innentemperatur von 20 °C und einer Außentemperatur von Tj				Deklarierte Leistungszahl oder Primärenergiekennzahl für Teillast bei einer Innentemperatur von 20 °C und einer Außentemperatur von Tj			
Tj = -7 °C	Pdh	122.2	kW	Tj = -7 °C	COPd	6.04	-
Tj = +2 °C	Pdh	125.1	kW	Tj = +2 °C	COPd	6.6	-
Tj = +7 °C	Pdh	127.2	kW	Tj = +7 °C	COPd	7.3	-
Tj = +12 °C	Pdh	129.3	kW	Tj = +12 °C	COPd	7.9	-
Tj = bivalente Temperatur	Pdh	121.4	kW	Tj = bivalente Temperatur	COPd	5.9	-
Tj = Betriebsgrenztemperatur	Pdh	---	kW	Tj = Betriebsgrenztemperatur	COPd	---	-
Bivalente Temperatur	Tbiv	-7	°C	Tj = Betriebsgrenztemperatur	TOL	---	°C
Stromverbrauch in anderen Modi als dem aktiven Modus				Betriebsgrenztemperatur des Heizwassers			
Aus-Zustand	Poff	0.040	kW	Zusatzheizung			
Thermostat-Aus-Modus	Pto	0.010	kW	Nennwärmeleistung	Psup	23.0	kW
Standby-Betrieb	Psb	0.010	kW	Art der Energiezufuhr			
Betriebsart Kurbelwannenheizung	Pck	0.050	kW	elektrisch			
Sonstige Angaben				Für Luft/Wasser-Wärmepumpen: Nennluftvolumenstrom, Außenbereich			
Leistungsregelung		mehrstufig		Für Wasser- oder Sole/Wasser-Wärmepumpen: Nenndurchfluss der Sole oder des Wassers, Wärmetauscher im Freien			
Schalleistungspegel							
in Innenräumen	Lwa	67	dB				
im Freien	Lwa	---	dB				
Jährlicher Energieverbrauch	QHE	36839.5	kWh				

Angaben zum Kontakt: WAMAK, s.r.o., Orovnica 252, 96652, Orovnica, Slovakia, info@wamak.sk

WAMAK TWW 220 WHR HeavyDuty 2L2

ErP (EU) No 811/2013: Technische Parameter für Wärmepumpen-Raumheizgeräte

Modell	TWW 220 WHR HeavyDuty 2L2
Luft-Wasser-Wärmepumpe	nein
Sole/Wasser-Wärmepumpe	nein
Wasser/Wasser-Wärmepumpe	ja
Niedertemperatur-Wärmepumpe	nein
Ausgestattet mit einer Zusatzheizung	nein
Wärmepumpen-Kombi-Heizgerät	nein
Temperaturanwendung	mittel (55 °C - 47 °C)
Klimaverhältnisse	durchschnittlich

Angabe	Symbol	Wert	Ein.	Angabe	Symbol	Wert	Ein.
Nennwärmeleistung bei Tdesignh	Prated	105.9	kW	Jahreszeitbedingte Raumheizungs-Energieeffizienz	η_s	203.2	%
Ausgewiesene Heizleistung für Teillast bei einer Innentemperatur von 20 °C und einer Außentemperatur von Tj				Deklarierte Leistungszahl oder Primärenergiekennzahl für Teillast bei einer Innentemperatur von 20 °C und einer Außentemperatur von Tj			
Tj = -7 °C	Pdh	110.8	kW	Tj = -7 °C	COPd	3.97	-
Tj = +2 °C	Pdh	119.6	kW	Tj = +2 °C	COPd	5.3	-
Tj = +7 °C	Pdh	123.9	kW	Tj = +7 °C	COPd	6.2	-
Tj = +12 °C	Pdh	127.2	kW	Tj = +12 °C	COPd	6.9	-
Tj = bivalente Temperatur	Pdh	105.9	kW	Tj = bivalente Temperatur	COPd	3.5	-
Tj = Betriebsgrenztemperatur	Pdh	---	kW	Tj = Betriebsgrenztemperatur	COPd	---	-
Bivalente Temperatur	Tbiv	-7	°C	Tj = Betriebsgrenztemperatur	TOL	---	°C
Stromverbrauch in anderen Modi als dem aktiven Modus				Betriebsgrenztemperatur des Heizwassers			
Aus-Zustand	Poff	0.040	kW	Zusatzheizung			
Thermostat-Aus-Modus	Pto	0.010	kW	Nennwärmeleistung	Psup	23.0	kW
Standby-Betrieb	Psb	0.010	kW	Art der Energiezufuhr			
Betriebsart Kurbelwannenheizung	Pck	0.050	kW	elektrisch			
Sonstige Angaben				Für Luft/Wasser-Wärmepumpen: Nennluftvolumenstrom, Außenbereich			
Leistungsregelung		mehrstufig		Für Wasser- oder Sole/Wasser-Wärmepumpen: Nenndurchfluss der Sole oder des Wassers, Wärmetauscher im Freien			
Schalleistungspegel							
in Innenräumen	Lwa	67	dB				
im Freien	Lwa	---	dB				
Jährlicher Energieverbrauch	QHE	42722.3	kWh				

Angaben zum Kontakt: WAMAK, s.r.o., Orovnic 252, 96652, Orovnic, Slovakia, info@wamak.sk



ENERG Y IIA
 енергия - ενεργεια IE IA



TWW 220 WHR
 HeavyDuty 2L2



55 °C

35 °C



A+++

A+++



67 dB



--- dB

■ 112
 ■ 106
 ■ 104
 kW

■ 124
 ■ 122
 ■ 116
 kW



2019

811/2013

TWW 220 WHR
 HeavyDuty 2L2

ErP Data

	55 °C	35 °C
Energy class	A+++	A+++
η [%]	203.2	269.8
P_{rated} [kW]	106	122
Q_{HE} [kWh/y]	42723	36840
SCOP [-]	5.08	6.74
$T_{bivalent}$ [°C]	-7	-7

CONTROLLER



+ QAA55/75 class VII 3.5% ↓
 - QAA55/75 class III 1.5% ↓

Heizleistung Daten	Wärmerückgewinnung		
Betriebsbedingungen	Qh	P	COP
W45 / W80	226.4	50.6	4.47
W30 / W70	168.2	41.6	4.04
W25 / W60	187.2	34.3	5.45

Normative Daten: Wasser - Wasser

Quelle - Wasser [10°C] / Niedrigtemp. [35°C]

Betriebsbedingungen	Qh	P	COP
1 W10 / W30-35	121.4	20.6	5.89
2 W10 / W30-35 (MIN)	30.4	5.0	6.05
A W10 / Wxx-34	122.2	20.2	6.04
B W10 / Wxx-30	125.1	18.8	6.65
C W10 / Wxx-27	127.2	17.8	7.32
D W10 / Wxx-24	129.3	16.9	7.86
E W10 / Wxx-35	121.4	20.6	5.89
F W10 / Wxx-35	121.4	20.6	5.89

SCOP DATA EN 14825:2018	
Quelle - Wasser [10°C] / Niedrigtemp. [35°C]	
SCOPon	6.81
SCOPnet	6.81
SCOP	6.74
η [%]	269.78
Label	A+++
Qh [kWh]	36840
Pdesignh [kW]	121.4
Tbivalent [°C]	-7.00

Quelle - Wasser [10°C] / Mitteltemp. [55°C]

Betriebsbedingungen	Qh	P	COP
1 W10 / W47-55	105.9	30.3	3.50
2 W10 / W47-55 (MIN)	26.5	7.4	3.59
A W10 / Wxx-52	110.8	27.9	3.97
B W10 / Wxx-42	119.6	22.6	5.29
C W10 / Wxx-36	123.9	20.4	6.22
D W10 / Wxx-30	127.2	18.8	6.93
E W10 / Wxx-55	105.9	30.3	3.50
F W10 / Wxx-55	105.9	30.3	3.50

SCOP DATA EN 14825:2018	
Quelle - Wasser [10°C] / Mitteltemp. [55°C]	
SCOPon	5.12
SCOPnet	5.12
SCOP	5.08
η [%]	203.19
Label	A+++
Qh [kWh]	42722
Pdesignh [kW]	105.9
Tbivalent [°C]	-7.00

Niedrigtemperatur Kühlung W 12 / 7°C

Betriebsbedingungen				Qc	P	EER	SEER DATA EN 14825:2018 [W 12 / 7°C]	
A	W30-35 / W12-7	64.3	21.8	2.95	SEERon	3.64		
B	W26-xx / W12-7	67.7	20.2	3.35	SEER	3.60		
C	W22-xx / W12-7	71.0	18.8	3.77	Qc [kWh]	35940		
D	W18-xx / W12-7	72.5	18.1	4.00	η [%]	143.96		

Flächenkühlung W 23 / 18°C

Betriebsbedingungen				Qc	P	EER	SEER DATA EN 14825:2018 [W 23 / 18°C]	
A	W50-xx / W23-18	72.4	32.8	2.21	SEERon	5.48		
B	W40-xx / W23-18	85.7	26.6	3.23	SEER	5.39		
C	W30-35 / W23-18	97.8	21.8	4.49	Qc [kWh]	35940		
D	W26-xx / W23-18	102.3	20.2	5.06	η [%]	215.53		

Leistungslinien - Heizen

- Qh-nom-35
- Qh-nom-55
- Qh-nom-60
- Qh-nom-70
- Qh-nom-80
- - - Qh-min-70

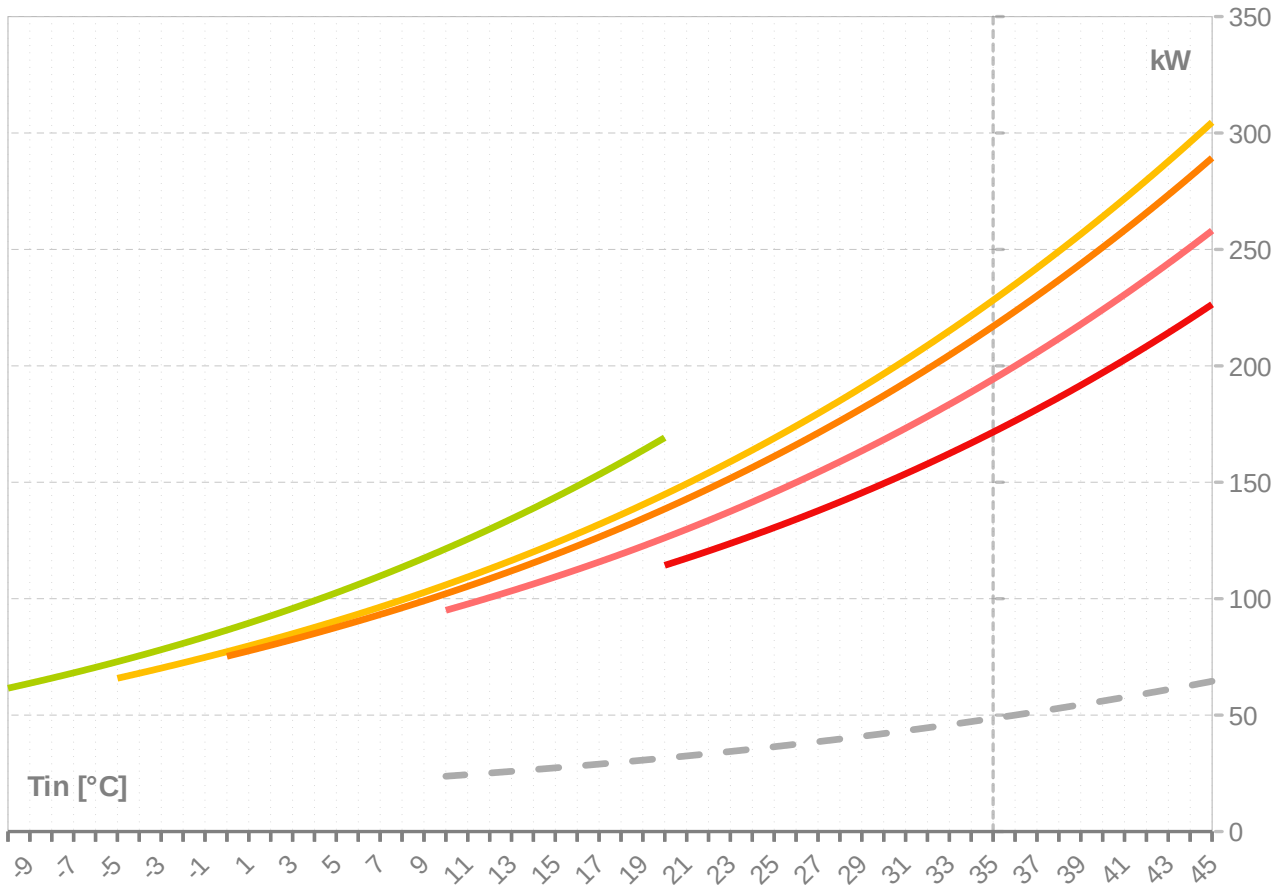

Leistungslinien - Kühlen

- Qc-nom-12-7
- Qc-nom-23-18

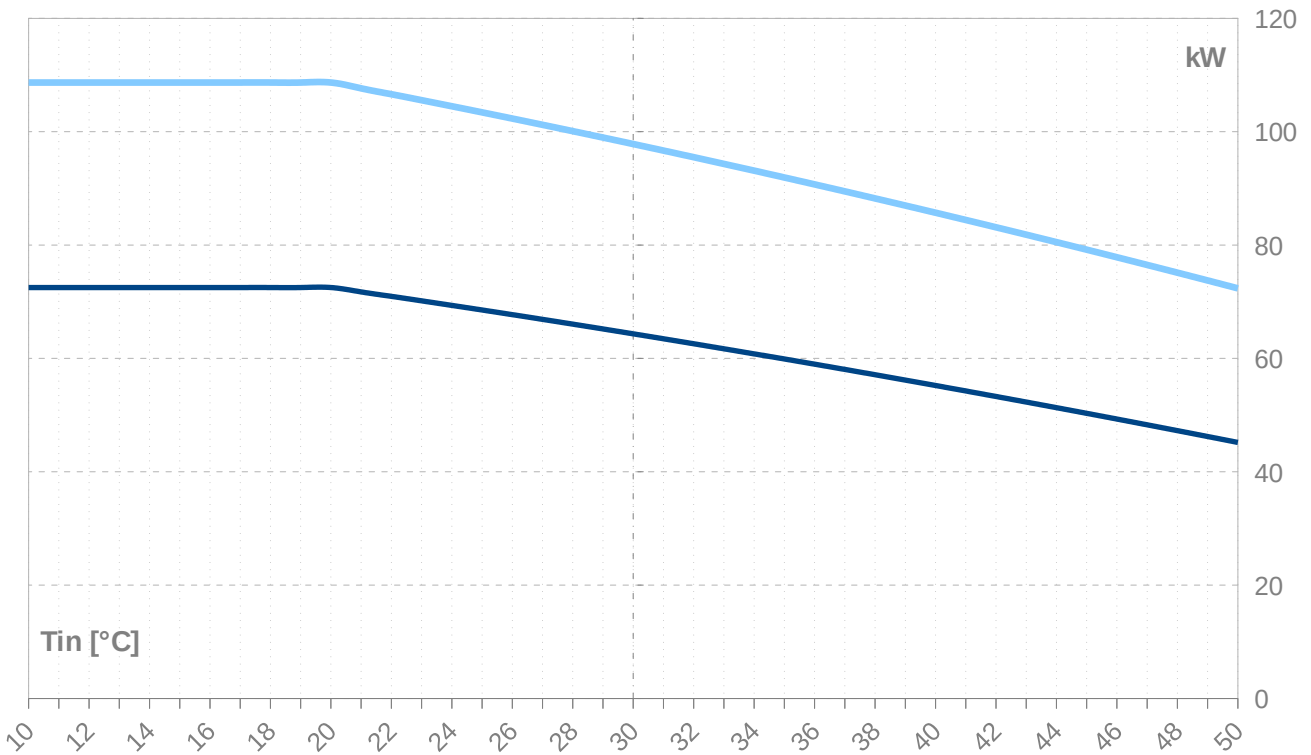

WAMAK TWW 220 WHR HeavyDuty 2L2

Tws -VL		55										
	[°C]	Qh nom	Qh min	Qh max	Pin nom	Pin min	Pin max	COP nom	Qc nom	Qc min	Qc max	I nom
Twq -RL	[°C]	[kW]	[kW]	[kW]	[kW]	[kW]	[kW]	kW / kW	[kW]	[kW]	[kW]	[A]
45	304.6	76.1	304.6	32.7	8.0	32.7	9.32	274.3	68.6	274.3	58.7	
44	296.1	74.0	296.1	32.6	7.9	32.6	9.09	265.9	66.5	265.9	58.5	
43	287.8	71.9	287.8	32.5	7.9	32.5	8.86	257.7	64.4	257.7	58.4	
42	279.7	69.9	279.7	32.4	7.9	32.4	8.64	249.7	62.4	249.7	58.3	
41	271.8	67.9	271.8	32.3	7.9	32.3	8.42	241.9	60.5	241.9	58.1	
40	264.1	66.0	264.1	32.2	7.8	32.2	8.21	234.2	58.6	234.2	58.0	
39	256.5	64.1	256.5	32.1	7.8	32.1	8.00	226.8	56.7	226.8	57.9	
38	249.2	62.3	249.2	32.0	7.8	32.0	7.79	219.5	54.9	219.5	57.8	
37	242.0	60.5	242.0	31.9	7.8	31.9	7.59	212.4	53.1	212.4	57.7	
36	235.0	58.7	235.0	31.8	7.7	31.8	7.39	205.5	51.4	205.5	57.6	
35	228.2	57.0	228.2	31.7	7.7	31.7	7.20	198.8	49.7	198.8	57.5	
34	221.5	55.4	221.5	31.6	7.7	31.6	7.00	192.2	48.0	192.2	57.4	
33	215.0	53.8	215.0	31.5	7.7	31.5	6.82	185.8	46.4	185.8	57.3	
32	208.7	52.2	208.7	31.5	7.7	31.5	6.63	179.5	44.9	179.5	57.2	
31	202.6	50.6	202.6	31.4	7.6	31.4	6.45	173.5	43.4	173.5	57.1	
30	196.6	49.1	196.6	31.3	7.6	31.3	6.28	167.5	41.9	167.5	57.0	
29	190.7	47.7	190.7	31.2	7.6	31.2	6.11	161.8	40.4	161.8	56.9	
28	185.0	46.3	185.0	31.2	7.6	31.2	5.94	156.1	39.0	156.1	56.8	
27	179.5	44.9	179.5	31.1	7.6	31.1	5.77	150.7	37.7	150.7	56.7	
26	174.1	43.5	174.1	31.0	7.6	31.0	5.61	145.3	36.3	145.3	56.7	
25	168.9	42.2	168.9	31.0	7.5	31.0	5.45	140.2	35.0	140.2	56.6	
24	163.8	40.9	163.8	30.9	7.5	30.9	5.30	135.1	33.8	135.1	56.5	
23	158.8	39.7	158.8	30.8	7.5	30.8	5.15	130.2	32.6	130.2	56.4	
22	154.0	38.5	154.0	30.8	7.5	30.8	5.00	125.5	31.4	125.5	56.4	
21	149.3	37.3	149.3	30.7	7.5	30.7	4.86	120.8	30.2	120.8	56.3	
20	144.8	36.2	144.8	30.7	7.5	30.7	4.72	116.3	29.1	116.3	56.2	
19	140.4	35.1	140.4	30.6	7.5	30.6	4.58	112.0	28.0	112.0	56.2	
18	136.1	34.0	136.1	30.6	7.4	30.6	4.45	107.7	26.9	107.7	56.1	
17	131.9	33.0	131.9	30.5	7.4	30.5	4.32	103.6	25.9	103.6	56.1	
16	127.8	32.0	127.8	30.5	7.4	30.5	4.19	99.6	24.9	99.6	56.0	
15	123.9	31.0	123.9	30.4	7.4	30.4	4.07	95.7	23.9	95.7	56.0	
14	120.1	30.0	120.1	30.4	7.4	30.4	3.95	91.9	23.0	91.9	55.9	
13	116.4	29.1	116.4	30.4	7.4	30.4	3.83	88.2	22.1	88.2	55.9	
12	112.8	28.2	112.8	30.3	7.4	30.3	3.72	84.7	21.2	84.7	55.9	
11	109.3	27.3	109.3	30.3	7.4	30.3	3.61	81.2	20.3	81.2	55.8	
10	105.9	26.5	105.9	30.3	7.4	30.3	3.50	77.8	19.5	77.8	55.8	
9	102.6	25.7	102.6	30.2	7.4	30.2	3.39	74.6	18.6	74.6	55.8	
8	99.5	24.9	99.5	30.2	7.4	30.2	3.29	71.4	17.9	71.4	55.7	
7	96.4	24.1	96.4	30.2	7.4	30.2	3.19	68.4	17.1	68.4	55.7	
6	93.4	23.3	93.4	30.2	7.4	30.2	3.09	65.4	16.3	65.4	55.7	
5	90.5	22.6	90.5	30.2	7.3	30.2	3.00	62.5	15.6	62.5	55.7	
4	87.7	21.9	87.7	30.1	7.3	30.1	2.91	59.7	14.9	59.7	55.6	
3	84.9	21.2	84.9	30.1	7.3	30.1	2.82	57.0	14.2	57.0	55.6	
2	82.3	20.6	82.3	30.1	7.3	30.1	2.73	54.3	13.6	54.3	55.6	
1	79.7	19.9	79.7	30.1	7.3	30.1	2.65	51.8	12.9	51.8	55.6	
0	77.2	19.3	77.2	30.1	7.3	30.1	2.57	49.3	12.3	49.3	55.6	
-1	74.8	18.7	74.8	30.1	7.3	30.1	2.48	46.9	11.7	46.9	55.6	
-2	72.4	18.1	72.4	30.1	7.3	30.1	2.41	44.5	11.1	44.5	55.6	
-3	70.2	17.5	70.2	30.1	7.3	30.1	2.33	42.2	10.6	42.2	55.6	
-4	68.0	17.0	68.0	30.1	7.3	30.1	2.26	40.0	10.0	40.0	55.6	
-5	65.8	16.4	65.8	30.1	7.3	30.1	2.19	37.9	9.5	37.9	55.6	

-- Achtung: Betriebsgrenzen beachten - nicht in Tabelle festgehalten

ZR144KRE-TFD_R513A_4_WHR

WAMAK TWW 220 WHR HeavyDuty 2L2

Tws -VL		60										
	[°C]	Qh nom	Qh min	Qh max	Pin nom	Pin min	Pin max	COP nom	Qc nom	Qc min	Qc max	I nom
Twq -RL	[°C]	[kW]	[kW]	[kW]	[kW]	[kW]	[kW]	kw / kw	[kW]	[kW]	[kW]	[A]
45	289.3	72.3	289.3	35.4	8.6	35.4	8.16	256.4	64.1	256.4	62.0	
44	281.2	70.3	281.2	35.4	8.6	35.4	7.95	248.4	62.1	248.4	61.9	
43	273.4	68.3	273.4	35.3	8.6	35.3	7.75	240.7	60.2	240.7	61.8	
42	265.7	66.4	265.7	35.2	8.6	35.2	7.55	233.1	58.3	233.1	61.7	
41	258.2	64.6	258.2	35.1	8.6	35.1	7.36	225.7	56.4	225.7	61.6	
40	250.9	62.7	250.9	35.0	8.5	35.0	7.16	218.4	54.6	218.4	61.5	
39	243.8	60.9	243.8	34.9	8.5	34.9	6.98	211.4	52.8	211.4	61.4	
38	236.8	59.2	236.8	34.9	8.5	34.9	6.79	204.5	51.1	204.5	61.3	
37	230.0	57.5	230.0	34.8	8.5	34.8	6.61	197.8	49.4	197.8	61.2	
36	223.4	55.9	223.4	34.7	8.5	34.7	6.44	191.2	47.8	191.2	61.1	
35	217.0	54.2	217.0	34.6	8.4	34.6	6.26	184.8	46.2	184.8	61.0	
34	210.7	52.7	210.7	34.6	8.4	34.6	6.09	178.6	44.7	178.6	61.0	
33	204.6	51.1	204.6	34.5	8.4	34.5	5.93	172.6	43.1	172.6	60.9	
32	198.6	49.7	198.6	34.4	8.4	34.4	5.77	166.7	41.7	166.7	60.8	
31	192.8	48.2	192.8	34.4	8.4	34.4	5.61	160.9	40.2	160.9	60.7	
30	187.2	46.8	187.2	34.3	8.4	34.3	5.45	155.3	38.8	155.3	60.7	
29	181.7	45.4	181.7	34.3	8.4	34.3	5.30	149.9	37.5	149.9	60.6	
28	176.3	44.1	176.3	34.2	8.3	34.2	5.15	144.6	36.1	144.6	60.5	
27	171.1	42.8	171.1	34.2	8.3	34.2	5.01	139.4	34.9	139.4	60.5	
26	166.1	41.5	166.1	34.1	8.3	34.1	4.87	134.4	33.6	134.4	60.4	
25	161.1	40.3	161.1	34.1	8.3	34.1	4.73	129.5	32.4	129.5	60.3	
24	156.3	39.1	156.3	34.0	8.3	34.0	4.60	124.8	31.2	124.8	60.3	
23	151.7	37.9	151.7	34.0	8.3	34.0	4.47	120.2	30.0	120.2	60.2	
22	147.2	36.8	147.2	33.9	8.3	33.9	4.34	115.7	28.9	115.7	60.2	
21	142.8	35.7	142.8	33.9	8.3	33.9	4.21	111.3	27.8	111.3	60.1	
20	138.5	34.6	138.5	33.9	8.2	33.9	4.09	107.1	26.8	107.1	60.1	
19	134.4	33.6	134.4	33.8	8.2	33.8	3.97	103.0	25.7	103.0	60.0	
18	130.3	32.6	130.3	33.8	8.2	33.8	3.86	99.0	24.8	99.0	60.0	
17	126.4	31.6	126.4	33.7	8.2	33.7	3.75	95.1	23.8	95.1	60.0	
16	122.6	30.7	122.6	33.7	8.2	33.7	3.64	91.4	22.8	91.4	59.9	
15	119.0	29.7	119.0	33.7	8.2	33.7	3.53	87.7	21.9	87.7	59.9	
14	115.4	28.8	115.4	33.7	8.2	33.7	3.43	84.2	21.0	84.2	59.9	
13	111.9	28.0	111.9	33.6	8.2	33.6	3.33	80.7	20.2	80.7	59.9	
12	108.6	27.1	108.6	33.6	8.2	33.6	3.23	77.4	19.3	77.4	59.8	
11	105.3	26.3	105.3	33.6	8.2	33.6	3.13	74.1	18.5	74.1	59.8	
10	102.1	25.5	102.1	33.6	8.2	33.6	3.04	71.0	17.7	71.0	59.8	
9	99.1	24.8	99.1	33.6	8.2	33.6	2.95	67.9	17.0	67.9	59.8	
8	96.1	24.0	96.1	33.6	8.2	33.6	2.86	64.9	16.2	64.9	59.8	
7	93.2	23.3	93.2	33.6	8.2	33.6	2.78	62.1	15.5	62.1	59.8	
6	90.4	22.6	90.4	33.5	8.2	33.5	2.69	59.3	14.8	59.3	59.8	
5	87.7	21.9	87.7	33.5	8.2	33.5	2.61	56.6	14.1	56.6	59.7	
4	85.0	21.3	85.0	33.5	8.2	33.5	2.54	53.9	13.5	53.9	59.7	
3	82.5	20.6	82.5	33.5	8.2	33.5	2.46	51.4	12.8	51.4	59.7	
2	80.0	20.0	80.0	33.5	8.2	33.5	2.39	48.9	12.2	48.9	59.7	
1	77.6	19.4	77.6	33.5	8.2	33.5	2.31	46.5	11.6	46.5	59.7	
0	75.2	18.8	75.2	33.5	8.2	33.5	2.24	44.1	11.0	44.1	59.8	
-1												
-2												
-3												
-4												
-5												

-- Achtung: Betriebsgrenzen beachten - nicht in Tabelle festgehalten

WAMAK TWW 220 WHR HeavyDuty 2L2

Tws -VL		70										
	[°C]	Qh nom	Qh min	Qh max	Pin nom	Pin min	Pin max	COP nom	Qc nom	Qc min	Qc max	I nom
Twq -RL	[°C]	[kW]	[kW]	[kW]	[kW]	[kW]	[kW]	kW / kW	[kW]	[kW]	[kW]	[A]
45	258.1	64.5	258.1	42.1	10.3	42.1	6.13	219.0	54.8	219.0	70.5	
44	250.9	62.7	250.9	42.1	10.2	42.1	5.97	211.9	53.0	211.9	70.5	
43	244.0	61.0	244.0	42.0	10.2	42.0	5.81	205.0	51.3	205.0	70.4	
42	237.2	59.3	237.2	42.0	10.2	42.0	5.65	198.2	49.6	198.2	70.4	
41	230.6	57.6	230.6	41.9	10.2	41.9	5.50	191.7	47.9	191.7	70.3	
40	224.1	56.0	224.1	41.9	10.2	41.9	5.35	185.2	46.3	185.2	70.3	
39	217.8	54.5	217.8	41.9	10.2	41.9	5.20	179.0	44.7	179.0	70.2	
38	211.7	52.9	211.7	41.8	10.2	41.8	5.06	172.9	43.2	172.9	70.2	
37	205.7	51.4	205.7	41.8	10.2	41.8	4.92	167.0	41.7	167.0	70.2	
36	199.9	50.0	199.9	41.8	10.2	41.8	4.79	161.2	40.3	161.2	70.1	
35	194.3	48.6	194.3	41.7	10.2	41.7	4.65	155.6	38.9	155.6	70.1	
34	188.8	47.2	188.8	41.7	10.2	41.7	4.52	150.1	37.5	150.1	70.0	
33	183.4	45.9	183.4	41.7	10.2	41.7	4.40	144.8	36.2	144.8	70.0	
32	178.2	44.6	178.2	41.7	10.2	41.7	4.28	139.6	34.9	139.6	70.0	
31	173.2	43.3	173.2	41.7	10.2	41.7	4.16	134.5	33.6	134.5	70.0	
30	168.2	42.1	168.2	41.6	10.1	41.6	4.04	129.6	32.4	129.6	69.9	
29	163.5	40.9	163.5	41.6	10.1	41.6	3.93	124.8	31.2	124.8	69.9	
28	158.8	39.7	158.8	41.6	10.1	41.6	3.82	120.2	30.1	120.2	69.9	
27	154.3	38.6	154.3	41.6	10.1	41.6	3.71	115.7	28.9	115.7	69.9	
26	149.9	37.5	149.9	41.6	10.1	41.6	3.60	111.3	27.8	111.3	69.9	
25	145.6	36.4	145.6	41.6	10.1	41.6	3.50	107.1	26.8	107.1	69.9	
24	141.5	35.4	141.5	41.6	10.1	41.6	3.40	102.9	25.7	102.9	69.9	
23	137.5	34.4	137.5	41.6	10.1	41.6	3.31	98.9	24.7	98.9	69.9	
22	133.6	33.4	133.6	41.6	10.1	41.6	3.21	95.0	23.8	95.0	69.9	
21	129.8	32.4	129.8	41.6	10.1	41.6	3.12	91.2	22.8	91.2	69.9	
20	126.1	31.5	126.1	41.6	10.1	41.6	3.03	87.6	21.9	87.6	69.9	
19	122.6	30.6	122.6	41.6	10.1	41.6	2.95	84.0	21.0	84.0	69.9	
18	119.1	29.8	119.1	41.6	10.1	41.6	2.87	80.5	20.1	80.5	69.9	
17	115.8	28.9	115.8	41.6	10.1	41.6	2.78	77.2	19.3	77.2	69.9	
16	112.5	28.1	112.5	41.6	10.1	41.6	2.71	73.9	18.5	73.9	69.9	
15	109.4	27.3	109.4	41.6	10.1	41.6	2.63	70.8	17.7	70.8	69.9	
14	106.3	26.6	106.3	41.6	10.1	41.6	2.55	67.7	16.9	67.7	69.9	
13	103.3	25.8	103.3	41.6	10.1	41.6	2.48	64.7	16.2	64.7	70.0	
12	100.5	25.1	100.5	41.6	10.1	41.6	2.41	61.9	15.5	61.9	70.0	
11	97.7	24.4	97.7	41.6	10.1	41.6	2.35	59.1	14.8	59.1	70.0	
10	95.0	23.7	95.0	41.7	10.2	41.7	2.28	56.3	14.1	56.3	70.0	
9												
8												
7												
6												
5												

-- Achtung: Betriebsgrenzen beachten - nicht in Tabelle festgehalten

WAMAK TWW 220 WHR HeavyDuty 2L2

Tws -VL		80										
	[°C]	Qh nom	Qh min	Qh max	Pin nom	Pin min	Pin max	COP nom	Qc nom	Qc min	Qc max	I nom
Twq -RL	[°C]	[kW]	[kW]	[kW]	[kW]	[kW]	[kW]	kW / kW	[kW]	[kW]	[kW]	[A]
45	226.4	56.6	226.4	50.6	12.3	50.6	4.47	179.4	44.9	179.4	82.0	
44	220.2	55.1	220.2	50.6	12.3	50.6	4.35	173.2	43.3	173.2	82.0	
43	214.2	53.5	214.2	50.6	12.3	50.6	4.23	167.2	41.8	167.2	82.0	
42	208.3	52.1	208.3	50.7	12.3	50.7	4.11	161.3	40.3	161.3	82.1	
41	202.6	50.7	202.6	50.7	12.3	50.7	4.00	155.6	38.9	155.6	82.1	
40	197.1	49.3	197.1	50.7	12.4	50.7	3.89	150.0	37.5	150.0	82.1	
39	191.7	47.9	191.7	50.7	12.4	50.7	3.78	144.6	36.2	144.6	82.1	
38	186.4	46.6	186.4	50.8	12.4	50.8	3.67	139.3	34.8	139.3	82.1	
37	181.3	45.3	181.3	50.8	12.4	50.8	3.57	134.2	33.6	134.2	82.2	
36	176.3	44.1	176.3	50.8	12.4	50.8	3.47	129.2	32.3	129.2	82.2	
35	171.5	42.9	171.5	50.8	12.4	50.8	3.37	124.4	31.1	124.4	82.2	
34	166.8	41.7	166.8	50.9	12.4	50.9	3.28	119.7	29.9	119.7	82.3	
33	162.3	40.6	162.3	50.9	12.4	50.9	3.19	115.1	28.8	115.1	82.3	
32	157.9	39.5	157.9	50.9	12.4	50.9	3.10	110.7	27.7	110.7	82.3	
31	153.6	38.4	153.6	51.0	12.4	51.0	3.01	106.3	26.6	106.3	82.4	
30	149.5	37.4	149.5	51.0	12.4	51.0	2.93	102.2	25.5	102.2	82.4	
29	145.4	36.4	145.4	51.0	12.4	51.0	2.85	98.1	24.5	98.1	82.5	
28	141.5	35.4	141.5	51.1	12.4	51.1	2.77	94.1	23.5	94.1	82.5	
27	137.7	34.4	137.7	51.1	12.5	51.1	2.69	90.3	22.6	90.3	82.6	
26	134.1	33.5	134.1	51.2	12.5	51.2	2.62	86.6	21.7	86.6	82.6	
25	130.5	32.6	130.5	51.2	12.5	51.2	2.55	83.0	20.8	83.0	82.7	
24	127.0	31.8	127.0	51.2	12.5	51.2	2.48	79.5	19.9	79.5	82.7	
23	123.7	30.9	123.7	51.3	12.5	51.3	2.41	76.1	19.0	76.1	82.8	
22	120.5	30.1	120.5	51.3	12.5	51.3	2.35	72.9	18.2	72.9	82.9	
21	117.3	29.3	117.3	51.4	12.5	51.4	2.28	69.7	17.4	69.7	82.9	
20	114.3	28.6	114.3	51.4	12.5	51.4	2.22	66.6	16.6	66.6	83.0	
19												
18												
17												
16												
15												
14												
13												
12												
11												
10												
9												
8												
7												
6												
5												

-- Achtung: Betriebsgrenzen beachten - nicht in Tabelle festgehalten

WAMAK TWW 220 WHR HeavyDuty 2L2

Tk -VL		W 12 / 7 °C									
[°C]	Qc nom [kW]	Qc min [kW]	Qc max [kW]	Pin nom [kW]	Pin min [kW]	Pin max [kW]	EER kW / kW	Qh nom [kW]	Qh min [kW]	Qh max [kW]	I nom [A]
40	55.2	13.8	55.2	26.6	6.5	26.6	2.08	79.8	20.0	79.8	51.5
39	56.2	14.0	56.2	26.0	6.3	26.0	2.16	80.3	20.1	80.3	50.9
38	57.1	14.3	57.1	25.5	6.2	25.5	2.24	80.8	20.2	80.8	50.3
37	58.0	14.5	58.0	25.0	6.1	25.0	2.32	81.2	20.3	81.2	49.7
36	59.0	14.7	59.0	24.5	6.0	24.5	2.41	81.7	20.4	81.7	49.2
35	59.9	15.0	59.9	24.0	5.9	24.0	2.49	82.2	20.5	82.2	48.7
34	60.8	15.2	60.8	23.5	5.7	23.5	2.58	82.6	20.7	82.6	48.2
33	61.7	15.4	61.7	23.1	5.6	23.1	2.67	83.1	20.8	83.1	47.7
32	62.6	15.6	62.6	22.6	5.5	22.6	2.76	83.6	20.9	83.6	47.2
31	63.5	15.9	63.5	22.2	5.4	22.2	2.86	84.1	21.0	84.1	46.8
30	64.3	16.1	64.3	21.8	5.3	21.8	2.95	84.6	21.1	84.6	46.4
29	65.2	16.3	65.2	21.4	5.2	21.4	3.05	85.0	21.3	85.0	45.9
28	66.1	16.5	66.1	21.0	5.1	21.0	3.15	85.5	21.4	85.5	45.5
27	66.9	16.7	66.9	20.6	5.0	20.6	3.25	86.0	21.5	86.0	45.2
26	67.7	16.9	67.7	20.2	4.9	20.2	3.35	86.5	21.6	86.5	44.8
25	68.5	17.1	68.5	19.9	4.8	19.9	3.45	87.0	21.7	87.0	44.4
24	69.4	17.3	69.4	19.5	4.8	19.5	3.56	87.4	21.9	87.4	44.1
23	70.2	17.5	70.2	19.2	4.7	19.2	3.66	87.9	22.0	87.9	43.7
22	71.0	17.7	71.0	18.8	4.6	18.8	3.77	88.4	22.1	88.4	43.4
21	71.7	17.9	71.7	18.5	4.5	18.5	3.88	88.9	22.2	88.9	43.1
20	72.5	18.1	72.5	18.1	4.4	18.1	4.00	89.3	22.3	89.3	42.8

Tc [°C]		W 23 / 18 °C									
[°C]	Qc nom [kW]	Qc min [kW]	Qc max [kW]	Pin nom [kW]	Pin min [kW]	Pin max [kW]	EER kW / kW	Qh nom [kW]	Qh min [kW]	Qh max [kW]	I nom [A]
0											
40	85.7	21.4	85.7	26.6	6.5	26.6	3.23	110.6	27.6	102.9	51.8
39	87.0	21.7	87.0	26.0	6.3	26.0	3.34	111.4	27.8	103.6	51.2
38	88.2	22.1	88.2	25.5	6.2	25.5	3.46	112.2	28.0	104.4	50.6
37	89.5	22.4	89.5	25.0	6.1	25.0	3.58	112.9	28.2	105.2	50.1
36	90.7	22.7	90.7	24.5	6.0	24.5	3.70	113.7	28.4	105.9	49.6
35	91.9	23.0	91.9	24.0	5.9	24.0	3.83	114.5	28.6	106.7	49.1
34	93.1	23.3	93.1	23.5	5.7	23.5	3.95	115.3	28.8	107.5	48.6
33	94.3	23.6	94.3	23.1	5.6	23.1	4.08	116.1	29.0	108.2	48.1
32	95.5	23.9	95.5	22.6	5.5	22.6	4.22	116.8	29.2	109.0	47.6
31	96.7	24.2	96.7	22.2	5.4	22.2	4.35	117.6	29.4	109.8	47.2
30	97.8	24.5	97.8	21.8	5.3	21.8	4.49	118.4	29.6	110.6	46.7
29	99.0	24.7	99.0	21.4	5.2	21.4	4.63	119.1	29.8	111.4	46.3
28	100.1	25.0	100.1	21.0	5.1	21.0	4.77	119.9	30.0	112.2	45.9
27	101.2	25.3	101.2	20.6	5.0	20.6	4.91	120.7	30.2	112.9	45.5
26	102.3	25.6	102.3	20.2	4.9	20.2	5.06	121.4	30.4	113.7	45.2
25	103.4	25.9	103.4	19.9	4.8	19.9	5.21	122.2	30.5	114.5	44.8
24	104.5	26.1	104.5	19.5	4.8	19.5	5.36	122.9	30.7	115.3	44.4
23	105.6	26.4	105.6	19.2	4.7	19.2	5.51	123.6	30.9	116.1	44.1
22	106.6	26.7	106.6	18.8	4.6	18.8	5.67	124.4	31.1	116.8	43.8
21	107.6	26.9	107.6	18.5	4.5	18.5	5.83	125.1	31.3	117.6	43.4
20	108.7	27.2	108.7	18.1	4.4	18.1	5.99	125.8	31.5	118.4	43.1

-- Achtung: Betriebsgrenzen beachten - nicht in Tabelle festgehalten

LEGENDE:

Twq-RL: Temperatur Wärmequelle - Eintritt [°C]

Tws-VL: Temperatur Wärmesenke - Vorlauf [°C]

Tk-VL: Temperatur Kältesenke - Vorlauf [°C]

Qh nom: Heizleistung nominal

Qh min: Heizleistung minimal

Qh max: Heizleistung maximal

Pin nom: Aufnahme bei nominaler Heizleistung

Pin min: Aufnahme bei minimaler Heizleistung

Pin max: Aufnahme bei maximaler Heizleistung

COP nom: Arbeitszahl bei nominaler Heizleistung

Qc nom: Kälteleistung/Energieentnahme bei nominaler Heizleistung

Qc min: Kälteleistung/Energieentnahme bei minimaler Heizleistung

Qc max: Kälteleistung/Energieentnahme bei maximaler Heizleistung

I nom: Stromaufnahme bei nominaler Heizleistung

EER: Arbeitszahl bei nominaler Kälteleistung

Betriebsgrenzen

Temp °C

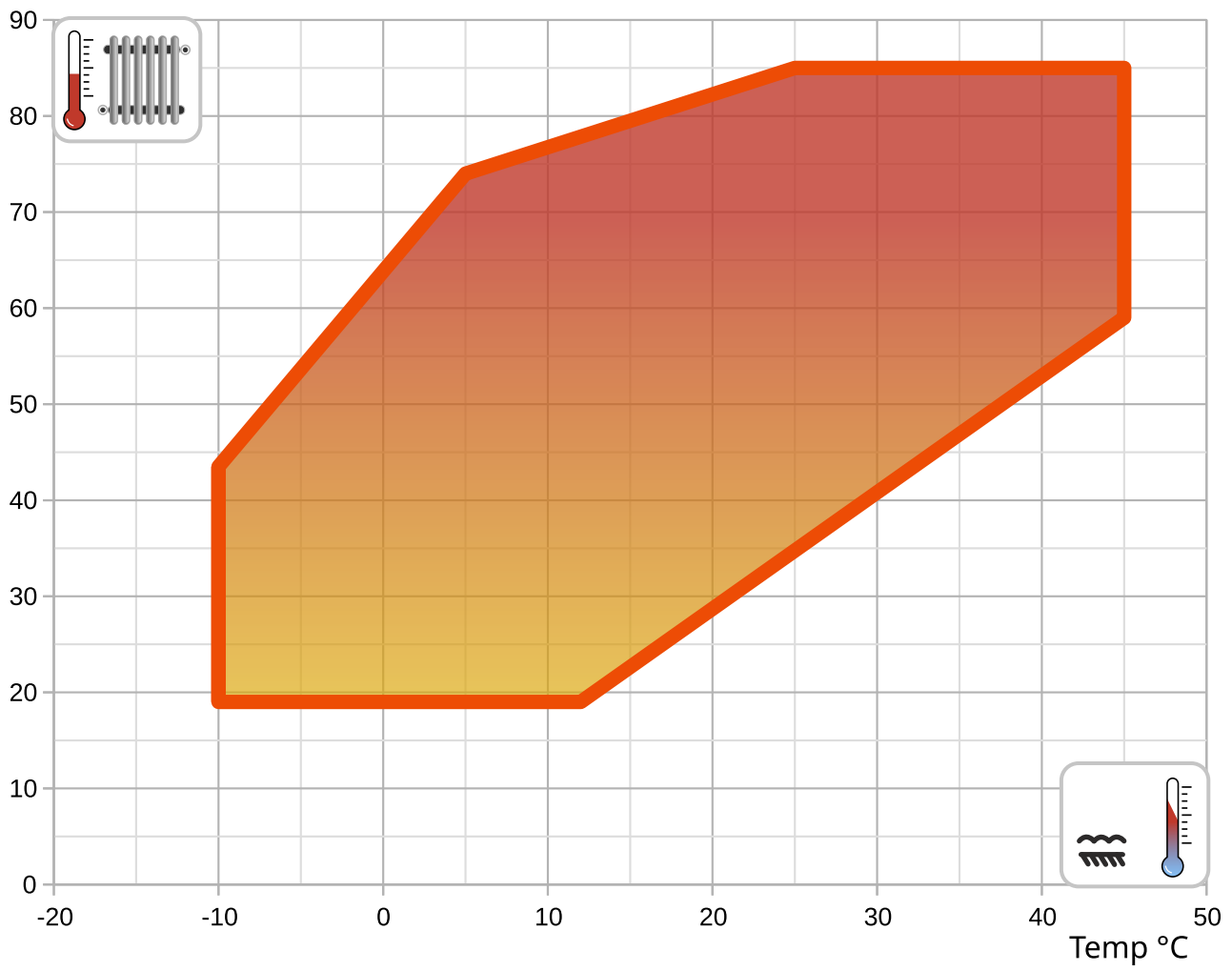

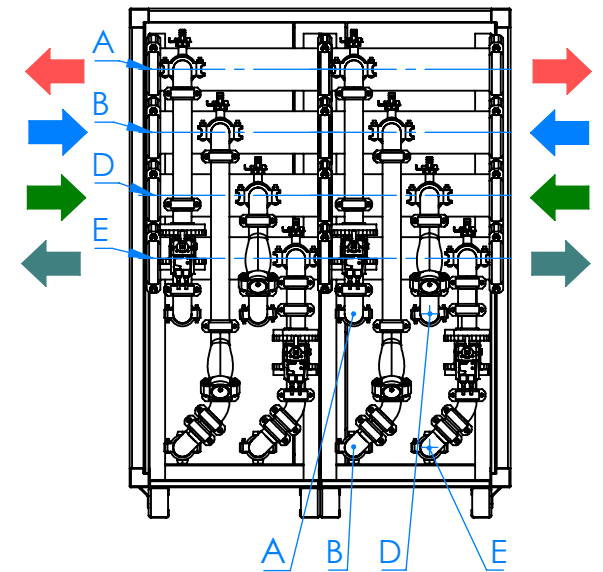
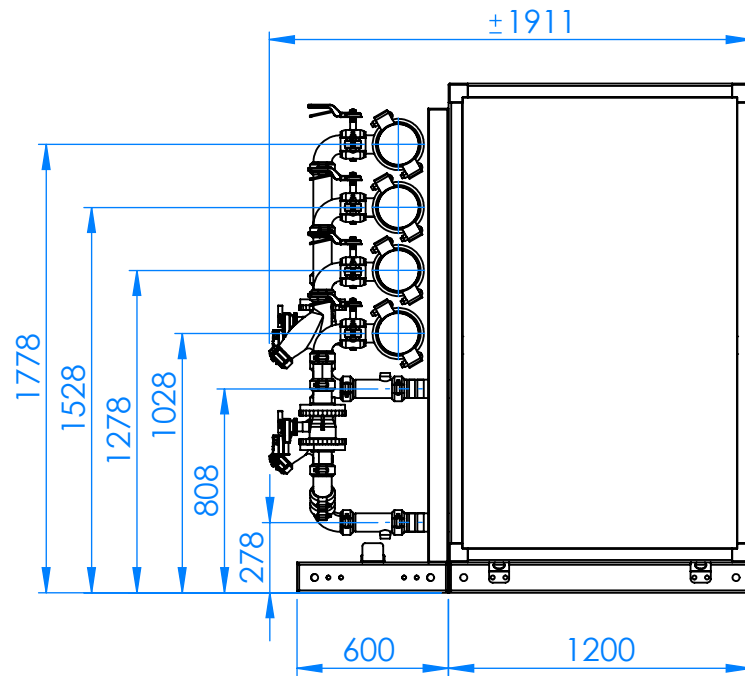
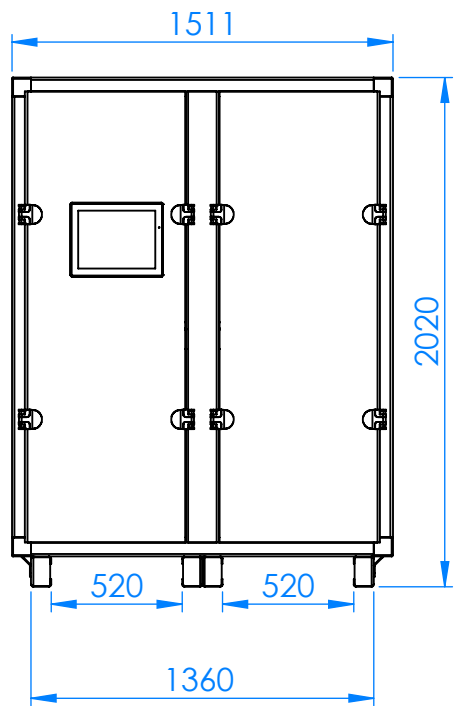

2xHD HD-M1

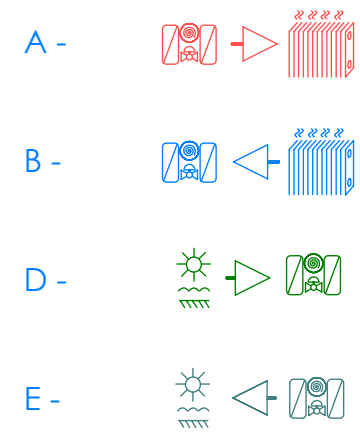
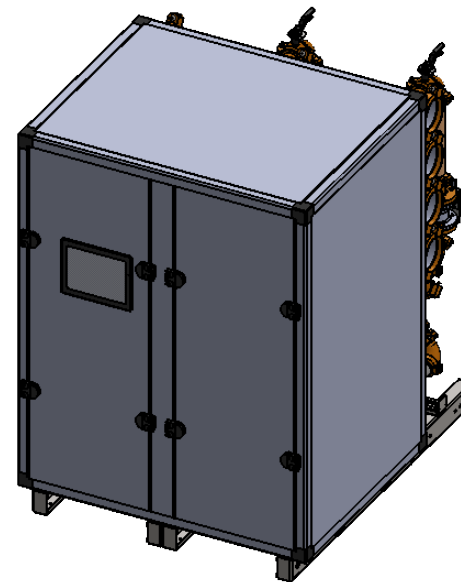
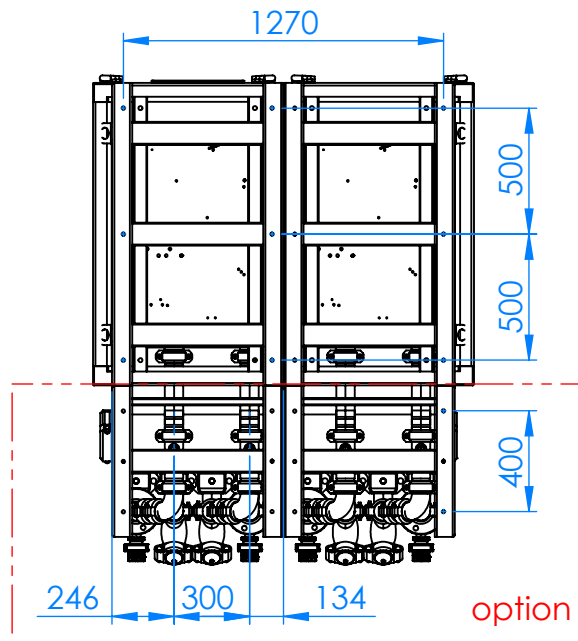

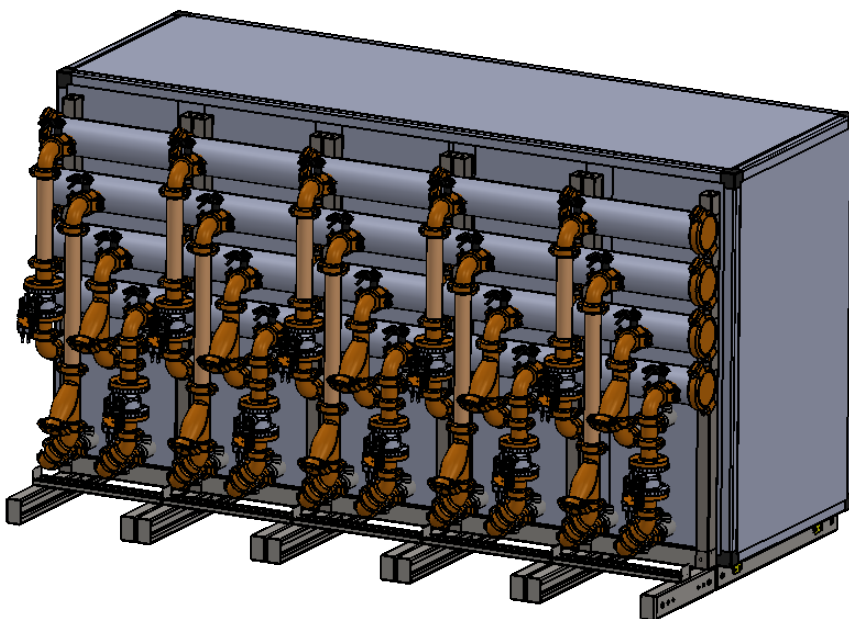
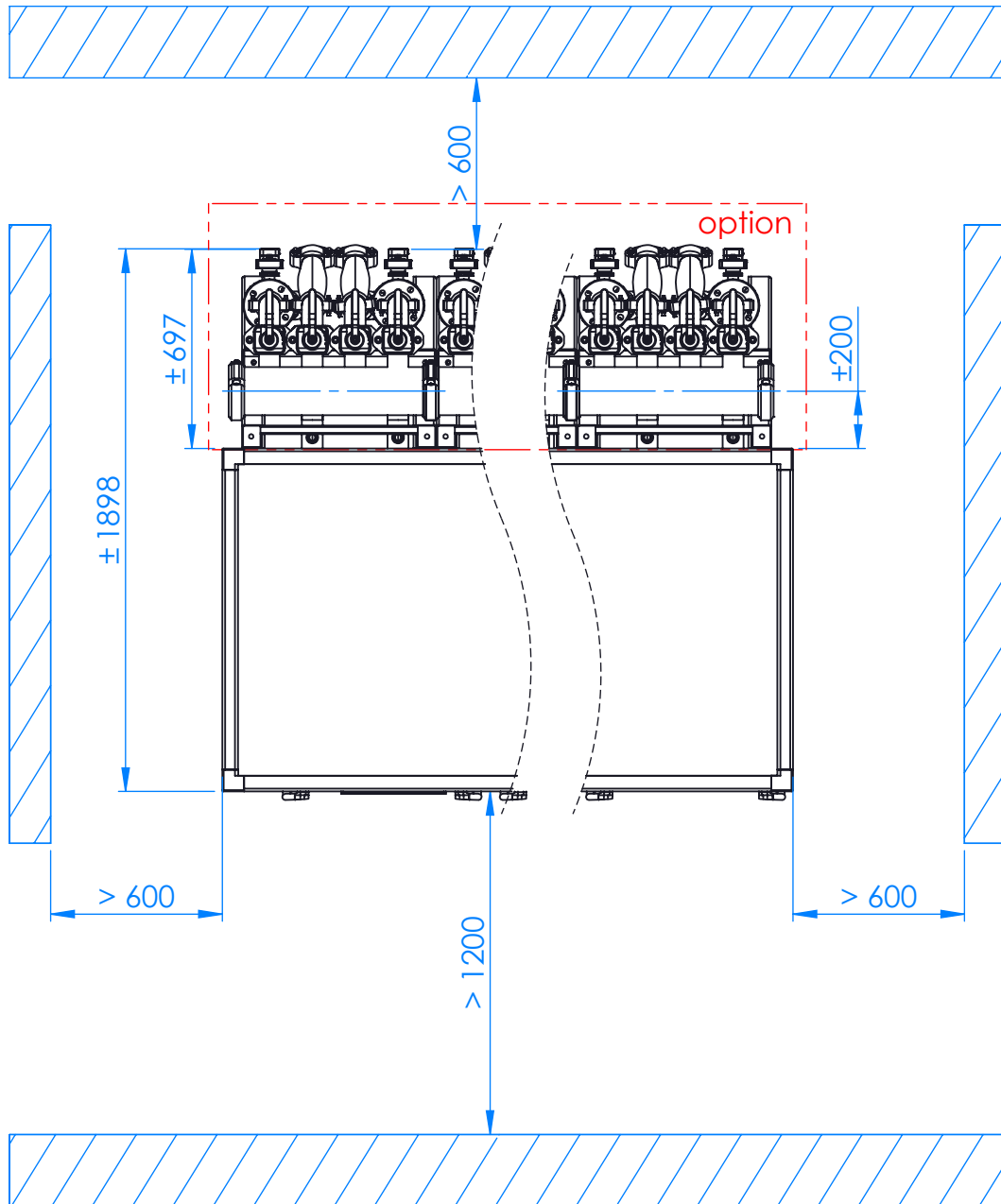

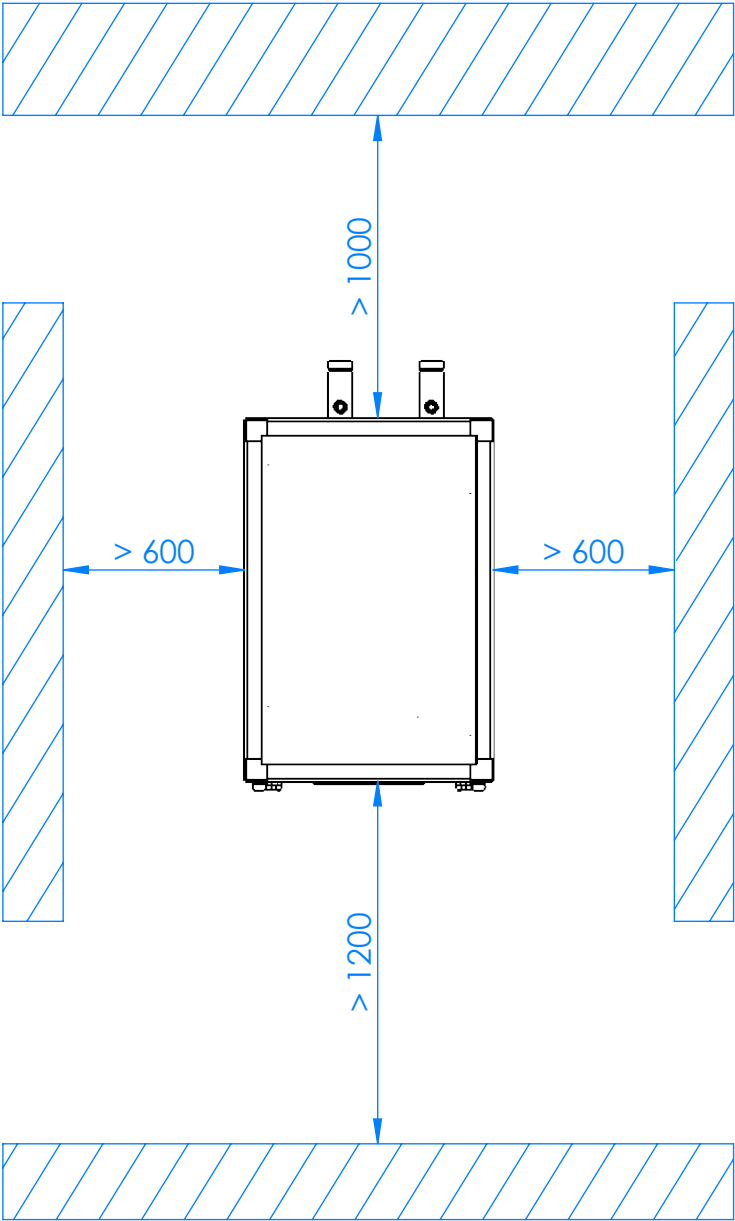

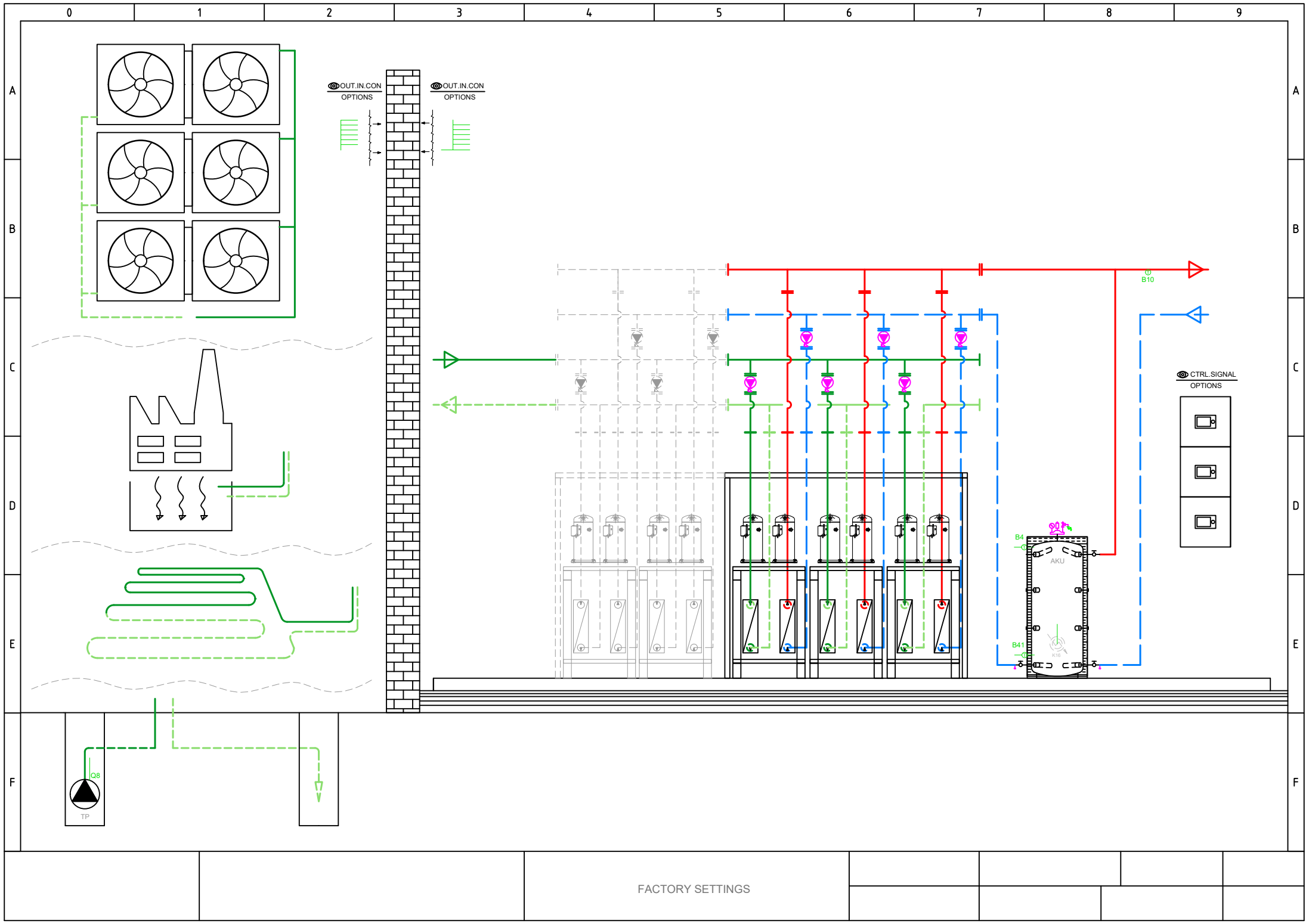

Total: max 6A
1 x QX...: max 2A

Netzanschluss 230V / 50 Hz
Erde
Nullleiter

- E9 Niederdruckwächter E9
- E10 Hochdruckwächter E10
- E15 Ström'wächter Quelle E15
- E24 Ström'wächter Verbrau E24
- E6 EW Sperre E6
- E12 Überlast Verdichter 2 E12
- E21 Drehstrom E21
- E22 Drehstrom E22
- E23 Drehstrom E23
- E11 Überlast Verdichter 1 E11
- K1 Verdichterstufe 1 K1

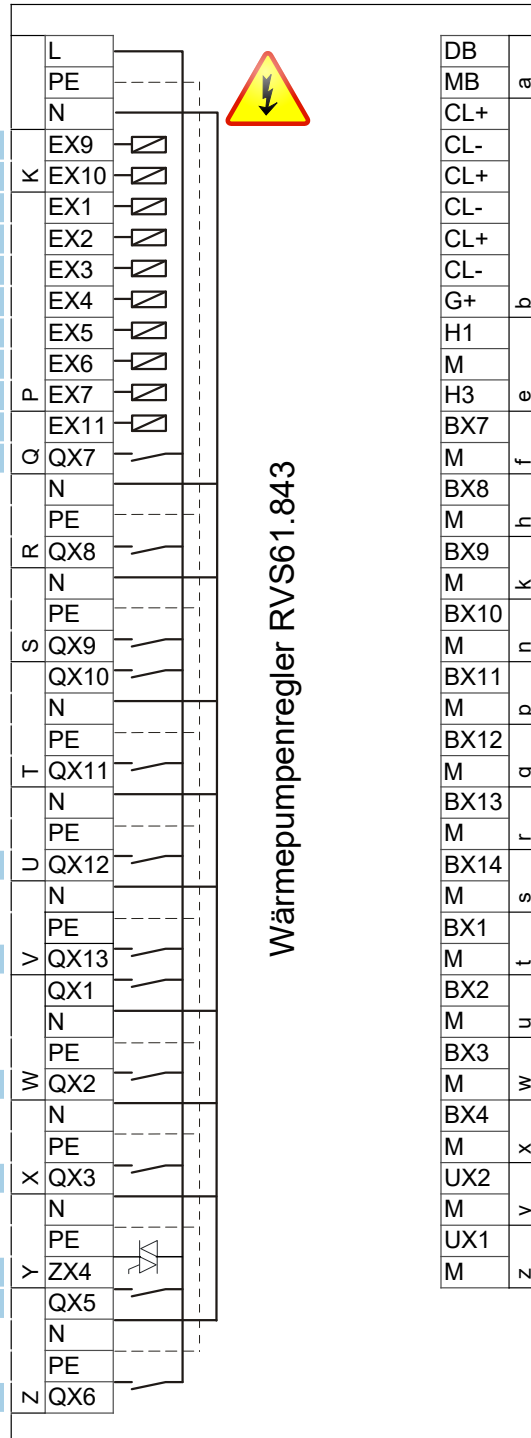

Wärmepumpenregler RVS61.843

Q8 Quellpumpe Q8

Q9 Kondensatorpumpe Q9

K10 Alarmausgang K10

K40 Ölumpfheizung K40

K81 Ventil Verdampfer K81

K82 Ventil EVI K82

K2 Verdichterstufe 2 K2

- DB LPB Bus Data
- MB LPB Bus Masse
- CL+ Raumgerät QAA...
- CL- Raumgerät QAA...
- CL+ Raumgerät QAA... 2.
- CL- Raumgerät QAA... 2.
- CL+ Raumgerät QAA... 3.
- CL- Raumgerät QAA... 3.
- G+ 12V Versorgung → AUS
- H1
- M
- H3 Verbr'anforderung VK1
- BX7 B81 Heissgasfühler K1 B81
- M
- BX8
- M
- BX9
- M
- BX10 B21 WP Vorlauffühler B21
- M
- BX11
- M
- BX12 B71 WP Rücklauffühler B71
- M
- BX13 B91 Quelleneintrittfühler B91
- M
- BX14 B84 Quellenaust'fühler B92/B84
- M
- BX1
- M
- BX2
- M
- BX3 B83 Kältemittelfühler flüssig B83
- M
- BX4 B82 Heissgasfühler K2 B82
- M
- UX2 Kondensatorpumpe Q9
- M
- UX1 0..10V Analogsignal
- M
- UX1 Quell'pumpe Q8
- M
- UX1 0..10V Analogsignal



- AVS75.390
- AVS75.391
- AVS75.370

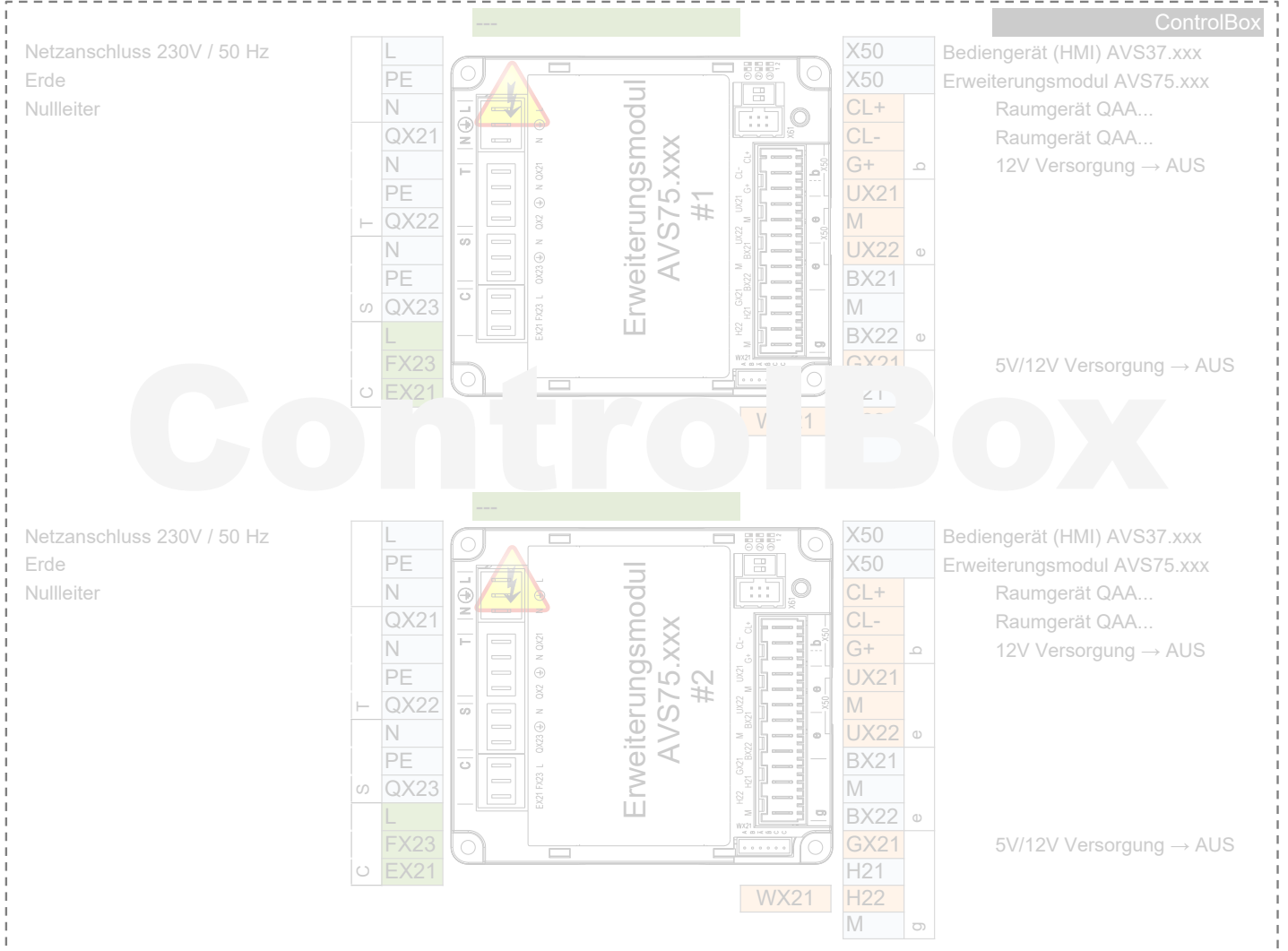

HEAT PUMP

EXTERNAL
INTERNAL

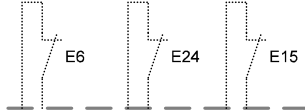

K1

K2

K82

K81

K40

K10

Q8 UX1

Q9 UX2

E11
KRW1
F1K
E11

E12
KRW2
F2K
E12

E6

Q9 ERR
F1S
E24

Q8 ERR
F1Z
E15

E10

E9

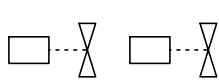

230V,50Hz max 6A

0...10V



DO



0...10V



DO



0...10V



DO



0...10V



DO



0...10V



DO



0...10V



DO



0...10V



DO



0...10V



DO



0...10V



DO



0...10V



DO



0...10V



DO



0...10V



DO

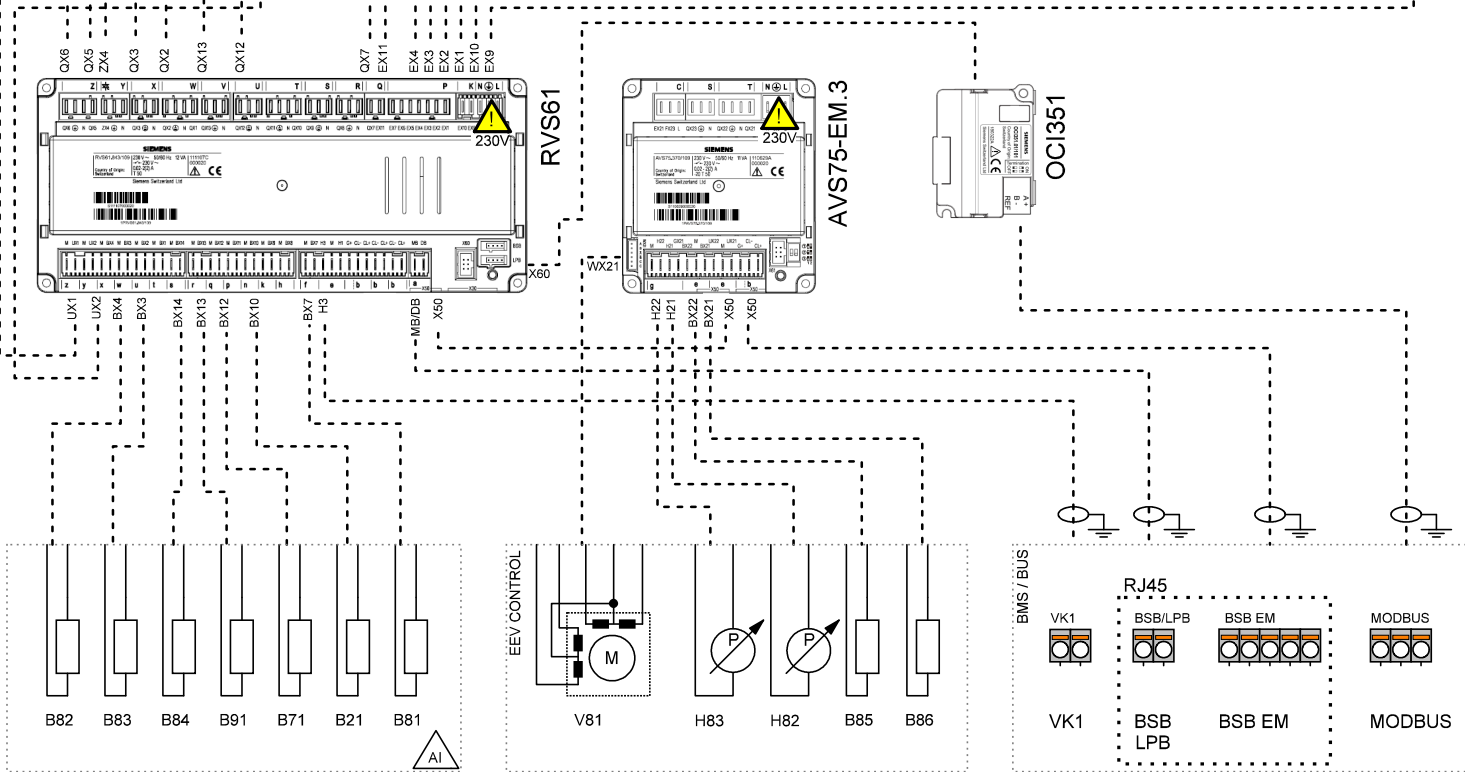
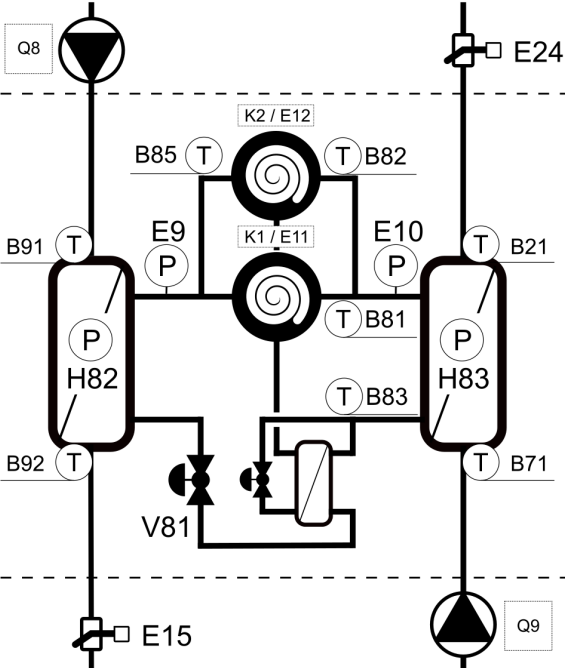

PWR SPLY: 3~ 400V, 50 Hz
CTRL: 1~ 230V, 50 HZ

Company	Title	Version / Note	Number	Created by	Date	Page
	TBW-TWW	05/2024				1



Company	Title	Version / Note	Number	Created by	Date	Page
	CONTROL BOX	05/2024				1



Company	Title	Version / Note	Number	Created by	Date	Page
	CONTROL BOX	05/2024				2



Company	Title	Version / Note	Number	Created by	Date	Page
	CONTROL BOX	05/2024				3



Company	Title	Version / Note	Number	Created by	Date	Page
	CONTROL BOX	05/2024				4



- AVS75.390
- AVS75.391
- AVS75.370

- AVS75.370**
 Netzanschluss 230V / 50 Hz
 Erde
 Nullleiter
Y1 Mischer Auf

Y2 Mischer Zu

Q2 Heizkreispumpe HK1 Q2

L Faze 230V
E61 Smart Grid E61

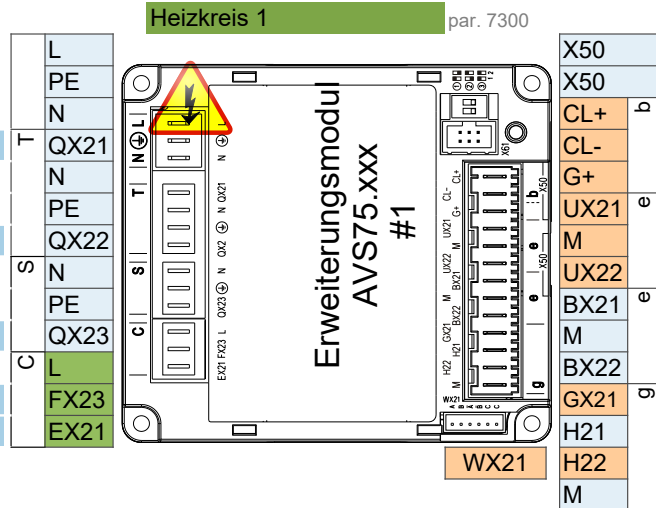

- Erweiterungsmodul AVS75.xxx
 Raumgerät QAA...
 Raumgerät QAA...

B1 Vorlauffühler 1

Impulszählung

- AVS75.370**
 Netzanschluss 230V / 50 Hz
 Erde
 Nullleiter
Q3 Trinkwasserstellglied Q3

K6 Elektroeinsatz TWW K6

Q6 Heizkreispumpe HK2 Q6

L Faze 230V
E62 Smart Grid E62

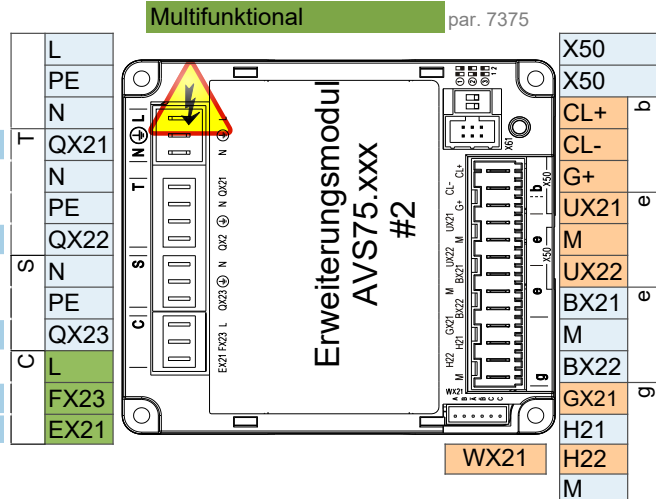

- Bediengerät (HMI) AVS37.xxx
 Erweiterungsmodul AVS75.xxx
 Raumgerät QAA...
 Raumgerät QAA...

B3 Trinkwasserfühler B3

B4 Pufferspeicherfühler B4

- Netzanschluss 230V / 50 Hz
 Erde
 Nullleiter

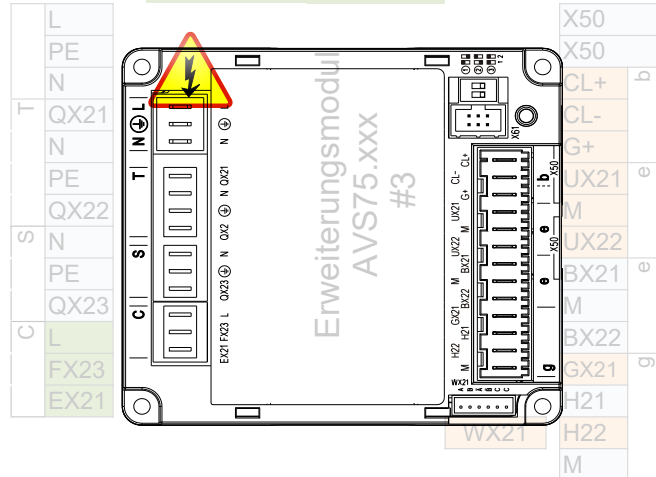

- Bediengerät (HMI) AVS37.xxx
 Erweiterungsmodul AVS75.xxx
 Raumgerät QAA...
 Raumgerät QAA...

Vorsicht: Erweiterungsmodul 3 ist in der Wärmepumpe

Anschlussmöglichkeiten für die Steuerung

1 ControlBox

ControlBox, mit zwei eingebauten Erweiterungsmodulen, ermöglicht zahlreiche Optionen für die Anwendungssteuerung auf der Verbraucherseite hinter der Wärmepumpe. Weitere Informationen finden Sie im Schaltplan der ControlBox und im Blatt mit den Anwendungsdiagrammen.

2 Fixer Sollwert Vorlauftemperatur - Ein / Aus potentialfreier Kontakt

2-adriges abgeschirmtes Kabel 2 x 0,5 mm² - Sollwert = 45°C (editierbar über Parameter 1859)

Anschlussklemme - siehe Schaltplan

3 Analog 0..10V Vorlauftemperatur-Sollwertregelung

2 Adern geschirmtes Kabel 2 x 0,5 mm² - Sollwert: 0V = 16°C ~ 10V = 60°C (editierbar im Parametersatz)

Anschlussklemme - siehe Schaltplan

4 ModBus RTU-Kommunikationsbefehl

3-adriges abgeschirmtes Kabel min. 3 x 0,25mm²

Für die ModBus-Zuordnungstabelle wenden Sie sich bitte an den technischen Support

5 MQTT IoT-Kommunikationsprotokoll

Für weitere Informationen wenden Sie sich bitte an den technischen Support