

Grundlegende Leistungsdaten - WAMAK TWW 110 WHR HeavyDuty 2L1

Heizen - EN 14511		
Wärmeleistung [kW]	W10 / W35 (max)	60.7 (30.4 / 60.7)
	W10 / W35 (min)	30.4 (30.4 / 60.7)
	W10 / W34	61.1 (30.5 / 61.1)
Leistungsaufnahme [kW]	W10 / W35 (max)	10.3 (5.1 / 10.3)
	W10 / W35 (min)	5.1 (5.1 / 10.3)
	W10 / W34	10.1 (5.0 / 10.1)
Leistungszahl Heizen [COP]	W10 / W35 (max)	5.89
	W10 / W35 (min)	6.00
	W10 / W34	6.04
Jahreszeitbedingte Raumheizungs-Energieeffizienz - SCOP EN 14825		
Klimazone Durchschnitt / Niedrigtemp. [35°C]	SCOP	6.66
	η [%]	266.5
	Label	A+++
	Qhe [kWh]	18475.0
	Pdesignh [kW]	60.7
	Tbivalent [°C]	-7
Kühlung		
Kühlleistung - [kW]	A35 / W23-18	46.0
	A25 / W23-18	51.7
	A35 / W12-7	29.9
	A25 / W12-7	29.9
Jahreszeitbedingte Raumkühlungs-Energieeffizienz - SEER EN 14825		
[W 23 / 18°C]	SEER	5.30
	Qce [kWh]	17940.0
	η_c [%]	212.1
Schall EN 12102		
Schalleistungspegel - Lw	dB(A)	61.6
Schalldruckpegel - Lp	1 m dB(A)	53.6
	5 m dB(A)	39.6
	10 m dB(A)	33.6
Mechanische und Betriebs-Informationen		
Verdichterbauart (3~ 400/50)	SCROLL / 2 /	Ein/Aus
Kältemittel	R513A (GWP - 631)	11.2 kg
Einsatzgrenze Heizungswasser - (min / max) [°C]		45 / 85
Einsatzgrenze Wärmequelle - (min / max) [°C]		-10 / 50
Gewicht		620 kg

Wichtigste technische Daten - WAMAK TWW 110 WHR HeavyDuty 2L1

Gehäuse Bezeichnung		HD2L1		Daten von Wärmeabgabe		
Grundlegende Abmessungen	Hohe [mm]	2000		Einsatzgrenze	MAX [°C]	85
	Breite [mm]	820		Heizungswasser	MIN [°C]	45
	Länge [mm]	1200		genauer siehe Betriebsgrenzendiagramm		
Gewicht [kg]	620		Kondensator	Anschlussdimension	VIC 2.1/2 "	
Gehäuse Farbe	Grau			Bauart	BPHE	
Gehäuse IP Klasse	IP20			Anzahl	1	
				Material	AISI 316	
Kältekreis				Maximaler Überdruck - Kältemittel [bar]	32	
Verdichter	Bauart	Scroll		Maximaler Überdruck - Wasser [bar]	6	
	Leistungstufen	2		Prüfdruck [bar]	70	
	Ein/Aus			Wärmeträger	Wasser	
	Leistungsfaktor Cosφ	0.63		Volumenstrom @ dT 5K (nom) - Wasser [m3/h]	7.28 ~ 14.55	
	Wicklungswiderstand	1.23 Ohm		Interne Druckdifferenz - Wasser [kPa]	20	
Kältemittel		R513A		Temperaturdifferenz	@ 35°C (nom)	5 K
	Menge	11.2 kg			@ 55°C	8 K
	GWP	631			@ 65°C	10 K
	Sicherheitsklasse	A1		Daten von Erneuerbarer Energiequelle		
Kältemittelöl	POE RL32-3MAF			Einsatzgrenze	MIN [°C]	-10
	Ölmenge	2 x 3.25 L		Wärmequelle	MAX [°C]	50
Maximaler Hochdruck - Kältemittel [bar]		32		genauer siehe Betriebsgrenzendiagramm		
	PED Klasse	2		Verdampfer	Anschlussdimension	VIC 2.1/2 "
EVI - Dampfeinspritzung mit Economiser			Bauart		BPHE	
Daten von Elektroanschluss			Anzahl		1	
Einspeisung [#~ V/Hz]	3~ 400/50		Material		AISI 316	
Strom	Nominal [A]	34.44		Maximaler Überdruck - Kältemittel [bar]	20	
	Maximal [A]	44.60		Wärmeträger	Wasser	
	Start [A]	12.9		Maximaler Überdruck - Wasser [bar]	6	
Sanftanlasser			Volumenstrom - Wasser [m3/h]	6.84 ~ 13.69		
Hauptsicherung	C80		Interne Druckdifferenz - Wasser [kPa]	20		
Steuerungssystem			Temperaturdifferenz - Wasser	4 K		
Hauptregler	SIEMENS	RVS 61				
Erweiterungsmo- dul	AVS75.3xx	AVS75.3xx	AVS75.372			
Bus Clip-In			Modbus OCI353			
Online-Verbindung	Web server OZW672		ToSyMo			
EEV Regelung			SEC61			

*** mit Zubehör

WAMAK TWW 110 WHR HeavyDuty 2L1

ErP (EU) No 811/2013: Technische Parameter für Wärmepumpen-Raumheizgeräte

Modell	TWW 110 WHR HeavyDuty 2L1
Luft-Wasser-Wärmepumpe	nein
Sole/Wasser-Wärmepumpe	nein
Wasser/Wasser-Wärmepumpe	ja
Niedertemperatur-Wärmepumpe	nein
Ausgestattet mit einer Zusatzheizung	nein
Wärmepumpen-Kombi-Heizgerät	nein
Temperaturanwendung	niedrig (35 °C - 30 °C)
Klimaverhältnisse	durchschnittlich

Angabe	Symbol	Wert	Ein.	Angabe	Symbol	Wert	Ein.
Nennwärmeleistung bei Tdesignh	Prated	60.7	kW	Jahreszeitbedingte Raumheizungs-Energieeffizienz	η_s	266.5	%
Ausgewiesene Heizleistung für Teillast bei einer Innentemperatur von 20 °C und einer Außentemperatur von Tj				Deklarierte Leistungszahl oder Primärenergiekennzahl für Teillast bei einer Innentemperatur von 20 °C und einer Außentemperatur von Tj			
Tj = -7 °C	Pdh	61.1	kW	Tj = -7 °C	COPd	6.04	-
Tj = +2 °C	Pdh	62.6	kW	Tj = +2 °C	COPd	6.6	-
Tj = +7 °C	Pdh	63.6	kW	Tj = +7 °C	COPd	7.3	-
Tj = +12 °C	Pdh	64.6	kW	Tj = +12 °C	COPd	7.8	-
Tj = bivalente Temperatur	Pdh	60.7	kW	Tj = bivalente Temperatur	COPd	5.9	-
Tj = Betriebsgrenztemperatur	Pdh	---	kW	Tj = Betriebsgrenztemperatur	COPd	---	-
Bivalente Temperatur	Tbiv	-7	°C	Tj = Betriebsgrenztemperatur	TOL	---	°C
Stromverbrauch in anderen Modi als dem aktiven Modus				Betriebsgrenztemperatur des Heizwassers	WTOL	85	°C
Aus-Zustand	Poff	0.040	kW	Zusatzheizung			
Thermostat-Aus-Modus	Pto	0.010	kW	Nennwärmeleistung	Psup	11.5	kW
Standby-Betrieb	Psb	0.010	kW	Art der Energiezufuhr	elektrisch		
Betriebsart Kurbelwannenheizung	Pck	0.050	kW	Sonstige Angaben			
Leistungsregelung				mehrstufig			
Schalleistungspegel				Für Luft/Wasser-Wärmepumpen: - --- m3/h Nennluftvolumenstrom, Außenbereich			
in Innenräumen	Lwa	62	dB	Für Wasser- oder Sole/Wasser-Wärmepumpen: Nenndurchfluss der Sole oder des Wassers, Wärmetauscher im Freien			
im Freien	Lwa	---	dB	- 6.84 ~ 13.69 m3/h			
Jährlicher Energieverbrauch	QHE	18475.0	kWh				

Angaben zum Kontakt: WAMAK, s.r.o., Orovnic 252, 96652, Orovnic, Slovakia, info@wamak.sk

WAMAK TWW 110 WHR HeavyDuty 2L1

ErP (EU) No 811/2013: Technische Parameter für Wärmepumpen-Raumheizgeräte

Modell	TWW 110 WHR HeavyDuty 2L1
Luft-Wasser-Wärmepumpe	nein
Sole/Wasser-Wärmepumpe	nein
Wasser/Wasser-Wärmepumpe	ja
Niedertemperatur-Wärmepumpe	nein
Ausgestattet mit einer Zusatzheizung	nein
Wärmepumpen-Kombi-Heizgerät	nein
Temperaturanwendung	mittel (55 °C - 47 °C)
Klimaverhältnisse	durchschnittlich

Angabe	Symbol	Wert	Ein.	Angabe	Symbol	Wert	Ein.
Nennwärmeleistung bei Tdesignh	Prated	53.0	kW	Jahreszeitbedingte Raumheizungs-Energieeffizienz	η_s	201.0	%
Ausgewiesene Heizleistung für Teillast bei einer Innentemperatur von 20 °C und einer Außentemperatur von Tj				Deklarierte Leistungszahl oder Primärenergiekennzahl für Teillast bei einer Innentemperatur von 20 °C und einer Außentemperatur von Tj			
Tj = -7 °C	Pdh	55.4	kW	Tj = -7 °C	COPd	3.97	-
Tj = +2 °C	Pdh	59.8	kW	Tj = +2 °C	COPd	5.3	-
Tj = +7 °C	Pdh	61.9	kW	Tj = +7 °C	COPd	6.2	-
Tj = +12 °C	Pdh	63.6	kW	Tj = +12 °C	COPd	6.9	-
Tj = bivalente Temperatur	Pdh	53.0	kW	Tj = bivalente Temperatur	COPd	3.5	-
Tj = Betriebsgrenztemperatur	Pdh	---	kW	Tj = Betriebsgrenztemperatur	COPd	---	-
Bivalente Temperatur	Tbiv	-7	°C	Tj = Betriebsgrenztemperatur	TOL	---	°C
Stromverbrauch in anderen Modi als dem aktiven Modus				Betriebsgrenztemperatur des Heizwassers	WTOL	85	°C
Aus-Zustand	Poff	0.040	kW	Zusatzheizung			
Thermostat-Aus-Modus	Pto	0.010	kW	Nennwärmeleistung	Psup	11.5	kW
Standby-Betrieb	Psb	0.010	kW	Art der Energiezufuhr	elektrisch		
Betriebsart Kurbelwannenheizung	Pck	0.050	kW				
Sonstige Angaben							
Leistungsregelung	mehrstufig			Für Luft/Wasser-Wärmepumpen: Nennluftvolumenstrom, Außenbereich	-	---	m ³ /h
Schalleistungspegel				Für Wasser- oder Sole/Wasser-Wärmepumpen: Nenndurchfluss der Sole oder des Wassers, Wärmetauscher im Freien	-	6.84 ~ 13.69	m ³ /h
in Innenräumen	Lwa	62	dB				
im Freien	Lwa	---	dB				
Jährlicher Energieverbrauch	Q _{HE}	21444.7	kWh				

Angaben zum Kontakt: WAMAK, s.r.o., Orovnic 252, 96652, Orovnic, Slovakia, info@wamak.sk



ENERG Y IJA
 енергия - ενεργεια IE IA



TWW 110 WHR
 HeavyDuty 2L1



55 °C

35 °C



A+++

A+++



62 dB



--- dB

■ 56
 ■ 53
 ■ 52
 kW

■ 62
 ■ 61
 ■ 58
 kW



2019

811/2013

TWW 110 WHR
 HeavyDuty 2L1

ErP Data

	55 °C	35 °C
Energy class	A+++	A+++
η [%]	201.0	266.5
P_{rated} [kW]	53	61
Q_{HE} [kWh/y]	21445	18475
SCOP [-]	5.03	6.66
$T_{bivalent}$ [°C]	-7	-7

CONTROLLER



+ QAA55/75
 - QAA55/75

class VII
 class III

3.5% ↓
 1.5% ↓

Heizleistung Daten	Wärmerückgewinnung		
Betriebsbedingungen	Qh	P	COP
W45 / W80	113.2	25.3	4.47
W30 / W70	84.1	20.8	4.04
W25 / W60	93.6	17.2	5.45

Normative Daten: Wasser - Wasser

Quelle - Wasser [10°C] / Niedrigtemp. [35°C]

Betriebsbedingungen	Qh	P	COP
1 W10 / W30-35	60.7	10.3	5.89
2 W10 / W30-35 (MIN)	30.4	5.1	6.00
A W10 / Wxx-34	61.1	10.1	6.04
B W10 / Wxx-30	62.6	9.4	6.65
C W10 / Wxx-27	63.6	8.9	7.26
D W10 / Wxx-24	64.6	8.4	7.79
E W10 / Wxx-35	60.7	10.3	5.89
F W10 / Wxx-35	60.7	10.3	5.89

SCOP DATA EN 14825:2018	
Quelle - Wasser [10°C] / Niedrigtemp. [35°C]	
SCOPon	6.79
SCOPnet	6.79
SCOP	6.66
η [%]	266.54
Label	A+++
Qh [kWh]	18475
Pdesignh [kW]	60.7
Tbivalent [°C]	-7.00

Quelle - Wasser [10°C] / Mitteltemp. [55°C]

Betriebsbedingungen	Qh	P	COP
1 W10 / W47-55	53.0	15.1	3.50
2 W10 / W47-55 (MIN)	26.5	7.4	3.56
A W10 / Wxx-52	55.4	14.0	3.97
B W10 / Wxx-42	59.8	11.3	5.29
C W10 / Wxx-36	61.9	10.2	6.16
D W10 / Wxx-30	63.6	9.4	6.87
E W10 / Wxx-55	53.0	15.1	3.50
F W10 / Wxx-55	53.0	15.1	3.50

SCOP DATA EN 14825:2018	
Quelle - Wasser [10°C] / Mitteltemp. [55°C]	
SCOPon	5.11
SCOPnet	5.11
SCOP	5.03
η [%]	201.01
Label	A+++
Qh [kWh]	21445
Pdesignh [kW]	53.0
Tbivalent [°C]	-7.00

Niedrigtemperatur Kühlung W 12 / 7°C

Betriebsbedingungen				Qc	P	EER	SEER DATA EN 14825:2018 [W 12 / 7°C]	
A	W30-35 / W12-7	32.2	10.9	2.95	SEERon	3.64		
B	W26-xx / W12-7	33.9	10.1	3.35	SEER	3.56		
C	W22-xx / W12-7	35.5	9.4	3.77	Qc [kWh]	17940		
D	W18-xx / W12-7	36.3	9.1	4.00	η [%]	142.41		

Flächenkühlung W 23 / 18°C

Betriebsbedingungen				Qc	P	EER	SEER DATA EN 14825:2018 [W 23 / 18°C]	
A	W50-xx / W23-18	36.2	16.4	2.21	SEERon	5.48		
B	W40-xx / W23-18	42.9	13.3	3.23	SEER	5.30		
C	W30-35 / W23-18	48.9	10.9	4.49	Qc [kWh]	17940		
D	W26-xx / W23-18	51.2	10.1	5.06	η [%]	212.07		

Leistungslinien - Heizen

- Qh-nom-35
- Qh-nom-55
- Qh-nom-60
- Qh-nom-70
- Qh-nom-80
- - - Qh-min-70

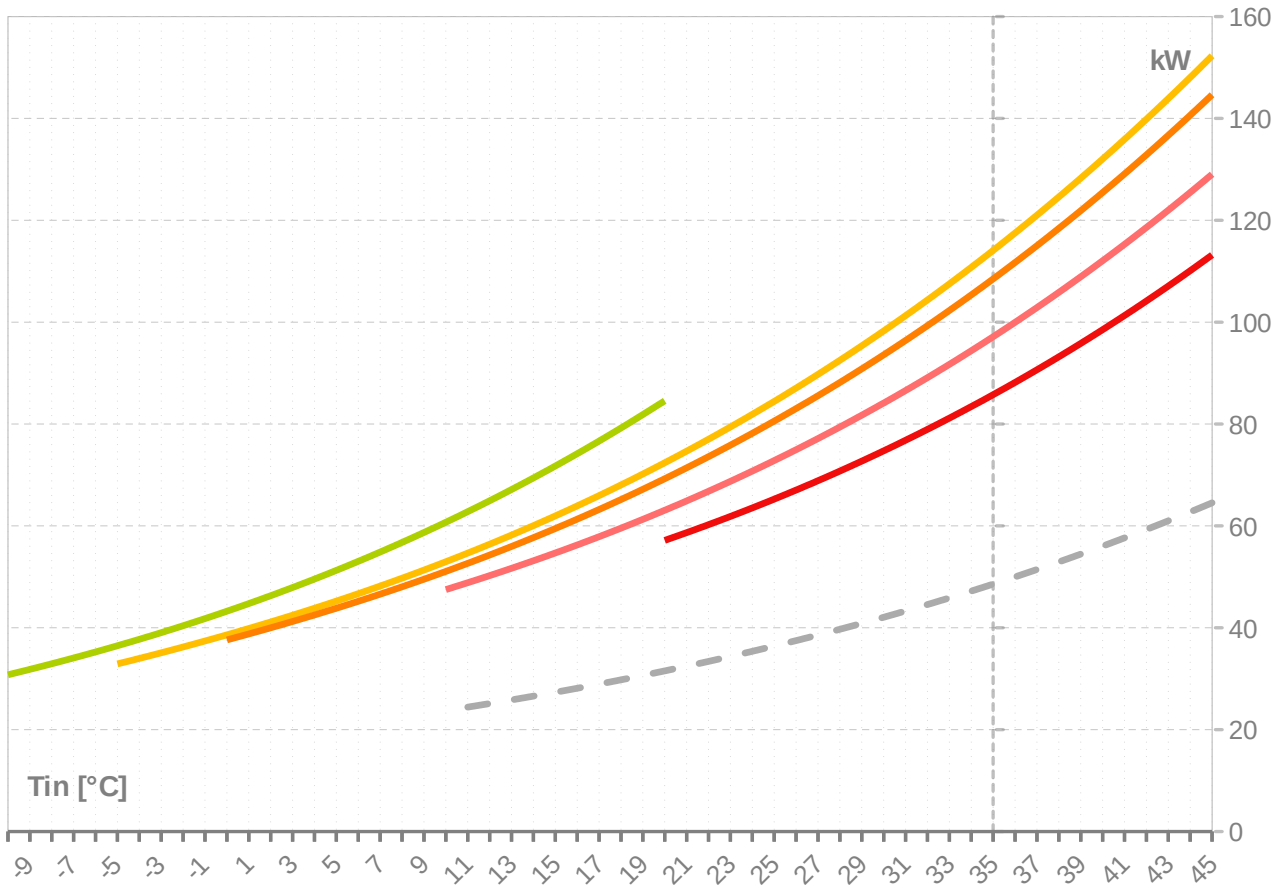

Leistungslinien - Kühlen

- Qc-nom-12-7
- Qc-nom-23-18

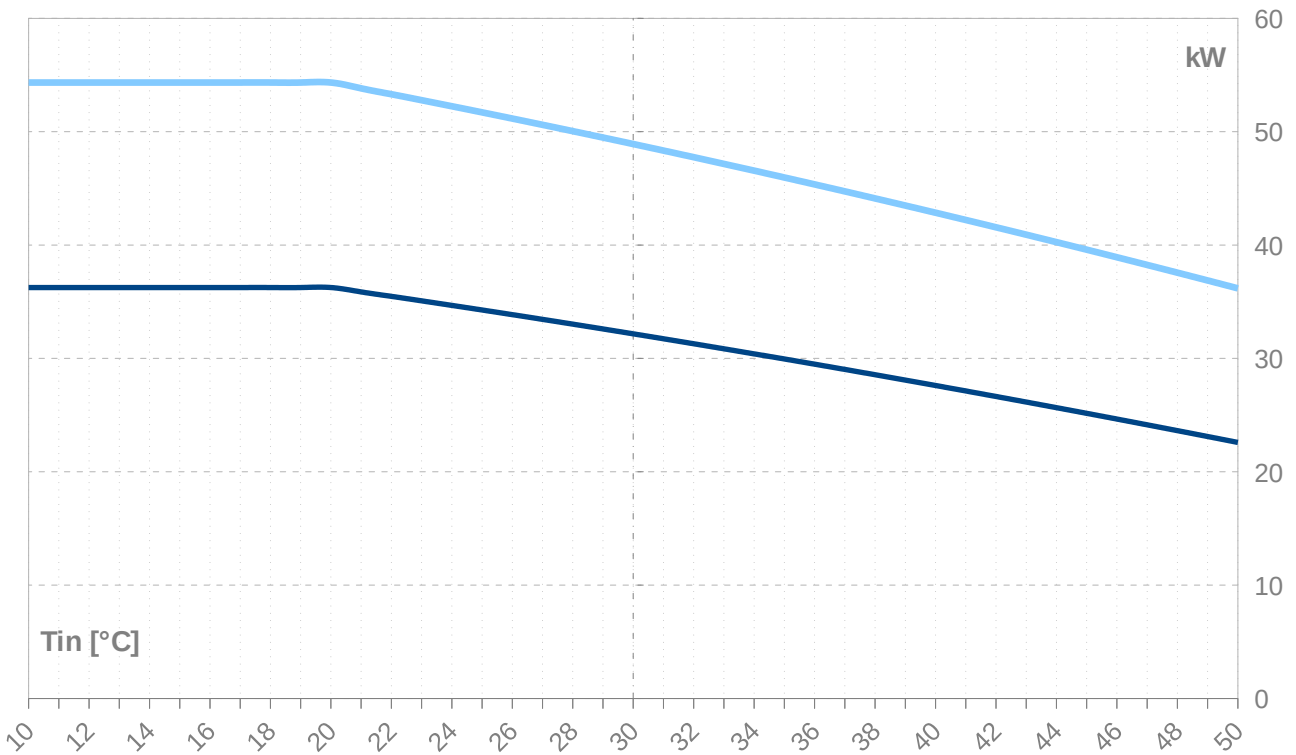

WAMAK TWW 110 WHR HeavyDuty 2L1

Tws -VL		55										
	[°C]	Qh nom	Qh min	Qh max	Pin nom	Pin min	Pin max	COP nom	Qc nom	Qc min	Qc max	I nom
Twq -RL	[°C]	[kW]	[kW]	[kW]	[kW]	[kW]	[kW]	kw / kw	[kW]	[kW]	[kW]	[A]
45	152.3	76.1	152.3	16.3	8.0	16.3	9.32	137.1	68.6	137.1	29.3	
44	148.0	74.0	148.0	16.3	8.0	16.3	9.09	132.9	66.5	132.9	29.3	
43	143.9	71.9	143.9	16.2	8.0	16.2	8.86	128.8	64.4	128.8	29.2	
42	139.8	69.9	139.8	16.2	8.0	16.2	8.64	124.8	62.4	124.8	29.1	
41	135.9	67.9	135.9	16.1	7.9	16.1	8.42	120.9	60.5	120.9	29.1	
40	132.0	66.0	132.0	16.1	7.9	16.1	8.21	117.1	58.6	117.1	29.0	
39	128.3	64.1	128.3	16.0	7.9	16.0	8.00	113.4	56.7	113.4	29.0	
38	124.6	62.3	124.6	16.0	7.9	16.0	7.79	109.8	54.9	109.8	28.9	
37	121.0	60.5	121.0	15.9	7.8	15.9	7.59	106.2	53.1	106.2	28.8	
36	117.5	58.7	117.5	15.9	7.8	15.9	7.39	102.8	51.4	102.8	28.8	
35	114.1	57.0	114.1	15.9	7.8	15.9	7.20	99.4	49.7	99.4	28.7	
34	110.8	55.4	110.8	15.8	7.8	15.8	7.00	96.1	48.0	96.1	28.7	
33	107.5	53.8	107.5	15.8	7.8	15.8	6.82	92.9	46.4	92.9	28.6	
32	104.4	52.2	104.4	15.7	7.7	15.7	6.63	89.8	44.9	89.8	28.6	
31	101.3	50.6	101.3	15.7	7.7	15.7	6.45	86.7	43.4	86.7	28.5	
30	98.3	49.1	98.3	15.7	7.7	15.7	6.28	83.8	41.9	83.8	28.5	
29	95.4	47.7	95.4	15.6	7.7	15.6	6.11	80.9	40.4	80.9	28.5	
28	92.5	46.3	92.5	15.6	7.7	15.6	5.94	78.1	39.0	78.1	28.4	
27	89.8	44.9	89.8	15.5	7.6	15.5	5.77	75.3	37.7	75.3	28.4	
26	87.1	43.5	87.1	15.5	7.6	15.5	5.61	72.7	36.3	72.7	28.3	
25	84.4	42.2	84.4	15.5	7.6	15.5	5.45	70.1	35.0	70.1	28.3	
24	81.9	40.9	81.9	15.4	7.6	15.4	5.30	67.6	33.8	67.6	28.3	
23	79.4	39.7	79.4	15.4	7.6	15.4	5.15	65.1	32.6	65.1	28.2	
22	77.0	38.5	77.0	15.4	7.6	15.4	5.00	62.7	31.4	62.7	28.2	
21	74.7	37.3	74.7	15.4	7.6	15.4	4.86	60.4	30.2	60.4	28.2	
20	72.4	36.2	72.4	15.3	7.5	15.3	4.72	58.2	29.1	58.2	28.1	
19	70.2	35.1	70.2	15.3	7.5	15.3	4.58	56.0	28.0	56.0	28.1	
18	68.0	34.0	68.0	15.3	7.5	15.3	4.45	53.9	26.9	53.9	28.1	
17	65.9	33.0	65.9	15.3	7.5	15.3	4.32	51.8	25.9	51.8	28.0	
16	63.9	32.0	63.9	15.2	7.5	15.2	4.19	49.8	24.9	49.8	28.0	
15	62.0	31.0	62.0	15.2	7.5	15.2	4.07	47.8	23.9	47.8	28.0	
14	60.0	30.0	60.0	15.2	7.5	15.2	3.95	45.9	23.0	45.9	28.0	
13	58.2	29.1	58.2	15.2	7.5	15.2	3.83	44.1	22.1	44.1	27.9	
12	56.4	28.2	56.4	15.2	7.5	15.2	3.72	42.3	21.2	42.3	27.9	
11	54.7	27.3	54.7	15.2	7.4	15.2	3.61	40.6	20.3	40.6	27.9	
10	53.0	26.5	53.0	15.1	7.4	15.1	3.50	38.9	19.5	38.9	27.9	
9	51.3	25.7	51.3	15.1	7.4	15.1	3.39	37.3	18.6	37.3	27.9	
8	49.7	24.9	49.7	15.1	7.4	15.1	3.29	35.7	17.9	35.7	27.9	
7	48.2	24.1	48.2	15.1	7.4	15.1	3.19	34.2	17.1	34.2	27.9	
6	46.7	23.3	46.7	15.1	7.4	15.1	3.09	32.7	16.3	32.7	27.8	
5	45.2	22.6	45.2	15.1	7.4	15.1	3.00	31.3	15.6	31.3	27.8	
4	43.8	21.9	43.8	15.1	7.4	15.1	2.91	29.9	14.9	29.9	27.8	
3	42.5	21.2	42.5	15.1	7.4	15.1	2.82	28.5	14.2	28.5	27.8	
2	41.1	20.6	41.1	15.1	7.4	15.1	2.73	27.2	13.6	27.2	27.8	
1	39.9	19.9	39.9	15.1	7.4	15.1	2.65	25.9	12.9	25.9	27.8	
0	38.6	19.3	38.6	15.1	7.4	15.1	2.57	24.6	12.3	24.6	27.8	
-1	37.4	18.7	37.4	15.0	7.4	15.0	2.48	23.4	11.7	23.4	27.8	
-2	36.2	18.1	36.2	15.0	7.4	15.0	2.41	22.3	11.1	22.3	27.8	
-3	35.1	17.5	35.1	15.0	7.4	15.0	2.33	21.1	10.6	21.1	27.8	
-4	34.0	17.0	34.0	15.1	7.4	15.1	2.26	20.0	10.0	20.0	27.8	
-5	32.9	16.4	32.9	15.1	7.4	15.1	2.19	18.9	9.5	18.9	27.8	

-- Achtung: Betriebsgrenzen beachten - nicht in Tabelle festgehalten

ZR144KRE-TFD_R513A_2_WHR

WAMAK TWW 110 WHR HeavyDuty 2L1

Tws -VL		60										
	[°C]	Qh nom	Qh min	Qh max	Pin nom	Pin min	Pin max	COP nom	Qc nom	Qc min	Qc max	I nom
Twq -RL	[°C]	[kW]	[kW]	[kW]	[kW]	[kW]	[kW]	kw / kw	[kW]	[kW]	[kW]	[A]
45	144.6	72.3	144.6	17.7	8.7	17.7	8.16	128.2	64.1	128.2	31.0	
44	140.6	70.3	140.6	17.7	8.7	17.7	7.95	124.2	62.1	124.2	31.0	
43	136.7	68.3	136.7	17.6	8.7	17.6	7.75	120.3	60.2	120.3	30.9	
42	132.8	66.4	132.8	17.6	8.6	17.6	7.55	116.5	58.3	116.5	30.8	
41	129.1	64.6	129.1	17.6	8.6	17.6	7.36	112.8	56.4	112.8	30.8	
40	125.5	62.7	125.5	17.5	8.6	17.5	7.16	109.2	54.6	109.2	30.7	
39	121.9	60.9	121.9	17.5	8.6	17.5	6.98	105.7	52.8	105.7	30.7	
38	118.4	59.2	118.4	17.4	8.6	17.4	6.79	102.2	51.1	102.2	30.7	
37	115.0	57.5	115.0	17.4	8.6	17.4	6.61	98.9	49.4	98.9	30.6	
36	111.7	55.9	111.7	17.4	8.5	17.4	6.44	95.6	47.8	95.6	30.6	
35	108.5	54.2	108.5	17.3	8.5	17.3	6.26	92.4	46.2	92.4	30.5	
34	105.4	52.7	105.4	17.3	8.5	17.3	6.09	89.3	44.7	89.3	30.5	
33	102.3	51.1	102.3	17.3	8.5	17.3	5.93	86.3	43.1	86.3	30.4	
32	99.3	49.7	99.3	17.2	8.5	17.2	5.77	83.3	41.7	83.3	30.4	
31	96.4	48.2	96.4	17.2	8.5	17.2	5.61	80.5	40.2	80.5	30.4	
30	93.6	46.8	93.6	17.2	8.4	17.2	5.45	77.7	38.8	77.7	30.3	
29	90.8	45.4	90.8	17.1	8.4	17.1	5.30	74.9	37.5	74.9	30.3	
28	88.2	44.1	88.2	17.1	8.4	17.1	5.15	72.3	36.1	72.3	30.3	
27	85.6	42.8	85.6	17.1	8.4	17.1	5.01	69.7	34.9	69.7	30.2	
26	83.0	41.5	83.0	17.1	8.4	17.1	4.87	67.2	33.6	67.2	30.2	
25	80.6	40.3	80.6	17.0	8.4	17.0	4.73	64.8	32.4	64.8	30.2	
24	78.2	39.1	78.2	17.0	8.4	17.0	4.60	62.4	31.2	62.4	30.1	
23	75.8	37.9	75.8	17.0	8.3	17.0	4.47	60.1	30.0	60.1	30.1	
22	73.6	36.8	73.6	17.0	8.3	17.0	4.34	57.9	28.9	57.9	30.1	
21	71.4	35.7	71.4	16.9	8.3	16.9	4.21	55.7	27.8	55.7	30.1	
20	69.3	34.6	69.3	16.9	8.3	16.9	4.09	53.6	26.8	53.6	30.0	
19	67.2	33.6	67.2	16.9	8.3	16.9	3.97	51.5	25.7	51.5	30.0	
18	65.2	32.6	65.2	16.9	8.3	16.9	3.86	49.5	24.8	49.5	30.0	
17	63.2	31.6	63.2	16.9	8.3	16.9	3.75	47.6	23.8	47.6	30.0	
16	61.3	30.7	61.3	16.9	8.3	16.9	3.64	45.7	22.8	45.7	30.0	
15	59.5	29.7	59.5	16.8	8.3	16.8	3.53	43.9	21.9	43.9	30.0	
14	57.7	28.8	57.7	16.8	8.3	16.8	3.43	42.1	21.0	42.1	29.9	
13	56.0	28.0	56.0	16.8	8.3	16.8	3.33	40.4	20.2	40.4	29.9	
12	54.3	27.1	54.3	16.8	8.3	16.8	3.23	38.7	19.3	38.7	29.9	
11	52.6	26.3	52.6	16.8	8.3	16.8	3.13	37.1	18.5	37.1	29.9	
10	51.1	25.5	51.1	16.8	8.3	16.8	3.04	35.5	17.7	35.5	29.9	
9	49.5	24.8	49.5	16.8	8.3	16.8	2.95	34.0	17.0	34.0	29.9	
8	48.0	24.0	48.0	16.8	8.2	16.8	2.86	32.5	16.2	32.5	29.9	
7	46.6	23.3	46.6	16.8	8.2	16.8	2.78	31.0	15.5	31.0	29.9	
6	45.2	22.6	45.2	16.8	8.2	16.8	2.69	29.6	14.8	29.6	29.9	
5	43.8	21.9	43.8	16.8	8.2	16.8	2.61	28.3	14.1	28.3	29.9	
4	42.5	21.3	42.5	16.8	8.2	16.8	2.54	27.0	13.5	27.0	29.9	
3	41.2	20.6	41.2	16.8	8.2	16.8	2.46	25.7	12.8	25.7	29.9	
2	40.0	20.0	40.0	16.8	8.2	16.8	2.39	24.4	12.2	24.4	29.9	
1	38.8	19.4	38.8	16.8	8.2	16.8	2.31	23.2	11.6	23.2	29.9	
0	37.6	18.8	37.6	16.8	8.2	16.8	2.24	22.1	11.0	22.1	29.9	
-1												
-2												
-3												
-4												
-5												

-- Achtung: Betriebsgrenzen beachten - nicht in Tabelle festgehalten

WAMAK TWW 110 WHR HeavyDuty 2L1

Tws -VL	70										
	Twq -RL [°C]	Qh nom [kW]	Qh min [kW]	Qh max [kW]	Pin nom [kW]	Pin min [kW]	Pin max [kW]	COP nom kW / kW	Qc nom [kW]	Qc min [kW]	Qc max [kW]
45	129.0	64.5	129.0	21.0	10.3	21.0	6.13	109.5	54.8	109.5	35.3
44	125.5	62.7	125.5	21.0	10.3	21.0	5.97	106.0	53.0	106.0	35.2
43	122.0	61.0	122.0	21.0	10.3	21.0	5.81	102.5	51.3	102.5	35.2
42	118.6	59.3	118.6	21.0	10.3	21.0	5.65	99.1	49.6	99.1	35.2
41	115.3	57.6	115.3	21.0	10.3	21.0	5.50	95.8	47.9	95.8	35.2
40	112.1	56.0	112.1	20.9	10.3	20.9	5.35	92.6	46.3	92.6	35.1
39	108.9	54.5	108.9	20.9	10.3	20.9	5.20	89.5	44.7	89.5	35.1
38	105.9	52.9	105.9	20.9	10.3	20.9	5.06	86.4	43.2	86.4	35.1
37	102.9	51.4	102.9	20.9	10.3	20.9	4.92	83.5	41.7	83.5	35.1
36	100.0	50.0	100.0	20.9	10.3	20.9	4.79	80.6	40.3	80.6	35.1
35	97.1	48.6	97.1	20.9	10.3	20.9	4.65	77.8	38.9	77.8	35.0
34	94.4	47.2	94.4	20.9	10.3	20.9	4.52	75.0	37.5	75.0	35.0
33	91.7	45.9	91.7	20.9	10.2	20.9	4.40	72.4	36.2	72.4	35.0
32	89.1	44.6	89.1	20.8	10.2	20.8	4.28	69.8	34.9	69.8	35.0
31	86.6	43.3	86.6	20.8	10.2	20.8	4.16	67.3	33.6	67.3	35.0
30	84.1	42.1	84.1	20.8	10.2	20.8	4.04	64.8	32.4	64.8	35.0
29	81.7	40.9	81.7	20.8	10.2	20.8	3.93	62.4	31.2	62.4	35.0
28	79.4	39.7	79.4	20.8	10.2	20.8	3.82	60.1	30.1	60.1	35.0
27	77.1	38.6	77.1	20.8	10.2	20.8	3.71	57.9	28.9	57.9	34.9
26	74.9	37.5	74.9	20.8	10.2	20.8	3.60	55.7	27.8	55.7	34.9
25	72.8	36.4	72.8	20.8	10.2	20.8	3.50	53.5	26.8	53.5	34.9
24	70.7	35.4	70.7	20.8	10.2	20.8	3.40	51.5	25.7	51.5	34.9
23	68.7	34.4	68.7	20.8	10.2	20.8	3.31	49.5	24.7	49.5	34.9
22	66.8	33.4	66.8	20.8	10.2	20.8	3.21	47.5	23.8	47.5	34.9
21	64.9	32.4	64.9	20.8	10.2	20.8	3.12	45.6	22.8	45.6	34.9
20	63.1	31.5	63.1	20.8	10.2	20.8	3.03	43.8	21.9	43.8	34.9
19	61.3	30.6	61.3	20.8	10.2	20.8	2.95	42.0	21.0	42.0	34.9
18	59.6	29.8	59.6	20.8	10.2	20.8	2.87	40.3	20.1	40.3	34.9
17	57.9	28.9	57.9	20.8	10.2	20.8	2.78	38.6	19.3	38.6	34.9
16	56.3	28.1	56.3	20.8	10.2	20.8	2.71	37.0	18.5	37.0	35.0
15	54.7	27.3	54.7	20.8	10.2	20.8	2.63	35.4	17.7	35.4	35.0
14	53.2	26.6	53.2	20.8	10.2	20.8	2.55	33.9	16.9	33.9	35.0
13	51.7	25.8	51.7	20.8	10.2	20.8	2.48	32.4	16.2	32.4	35.0
12	50.2	25.1	50.2	20.8	10.2	20.8	2.41	30.9	15.5	30.9	35.0
11	48.8	24.4	48.8	20.8	10.2	20.8	2.35	29.5	14.8	29.5	35.0
10	47.5	23.7	47.5	20.8	10.2	20.8	2.28	28.2	14.1	28.2	35.0
9											
8											
7											
6											
5											

-- Achtung: Betriebsgrenzen beachten - nicht in Tabelle festgehalten

WAMAK TWW 110 WHR HeavyDuty 2L1

Tws -VL		80										
	[°C]	Qh nom	Qh min	Qh max	Pin nom	Pin min	Pin max	COP nom	Qc nom	Qc min	Qc max	I nom
Twq -RL	[°C]	[kW]	[kW]	[kW]	[kW]	[kW]	[kW]	kW / kW	[kW]	[kW]	[kW]	[A]
45	113.2	56.6	113.2	25.3	12.4	25.3	4.47	89.7	44.9	89.7	41.0	
44	110.1	55.1	110.1	25.3	12.4	25.3	4.35	86.6	43.3	86.6	41.0	
43	107.1	53.5	107.1	25.3	12.4	25.3	4.23	83.6	41.8	83.6	41.0	
42	104.2	52.1	104.2	25.3	12.5	25.3	4.11	80.7	40.3	80.7	41.0	
41	101.3	50.7	101.3	25.3	12.5	25.3	4.00	77.8	38.9	77.8	41.0	
40	98.5	49.3	98.5	25.4	12.5	25.4	3.89	75.0	37.5	75.0	41.0	
39	95.8	47.9	95.8	25.4	12.5	25.4	3.78	72.3	36.2	72.3	41.1	
38	93.2	46.6	93.2	25.4	12.5	25.4	3.67	69.7	34.8	69.7	41.1	
37	90.6	45.3	90.6	25.4	12.5	25.4	3.57	67.1	33.6	67.1	41.1	
36	88.2	44.1	88.2	25.4	12.5	25.4	3.47	64.6	32.3	64.6	41.1	
35	85.8	42.9	85.8	25.4	12.5	25.4	3.37	62.2	31.1	62.2	41.1	
34	83.4	41.7	83.4	25.4	12.5	25.4	3.28	59.8	29.9	59.8	41.1	
33	81.1	40.6	81.1	25.4	12.5	25.4	3.19	57.5	28.8	57.5	41.2	
32	78.9	39.5	78.9	25.5	12.5	25.5	3.10	55.3	27.7	55.3	41.2	
31	76.8	38.4	76.8	25.5	12.5	25.5	3.01	53.2	26.6	53.2	41.2	
30	74.7	37.4	74.7	25.5	12.5	25.5	2.93	51.1	25.5	51.1	41.2	
29	72.7	36.4	72.7	25.5	12.5	25.5	2.85	49.0	24.5	49.0	41.2	
28	70.8	35.4	70.8	25.5	12.6	25.5	2.77	47.1	23.5	47.1	41.3	
27	68.9	34.4	68.9	25.6	12.6	25.6	2.69	45.2	22.6	45.2	41.3	
26	67.0	33.5	67.0	25.6	12.6	25.6	2.62	43.3	21.7	43.3	41.3	
25	65.2	32.6	65.2	25.6	12.6	25.6	2.55	41.5	20.8	41.5	41.3	
24	63.5	31.8	63.5	25.6	12.6	25.6	2.48	39.8	19.9	39.8	41.4	
23	61.9	30.9	61.9	25.6	12.6	25.6	2.41	38.1	19.0	38.1	41.4	
22	60.2	30.1	60.2	25.7	12.6	25.7	2.35	36.4	18.2	36.4	41.4	
21	58.7	29.3	58.7	25.7	12.6	25.7	2.28	34.8	17.4	34.8	41.5	
20	57.2	28.6	57.2	25.7	12.6	25.7	2.22	33.3	16.6	33.3	41.5	
19												
18												
17												
16												
15												
14												
13												
12												
11												
10												
9												
8												
7												
6												
5												

-- Achtung: Betriebsgrenzen beachten - nicht in Tabelle festgehalten

WAMAK TWW 110 WHR HeavyDuty 2L1

Tk -VL	W 12 / 7 °C										
	[°C]	Qc nom [kW]	Qc min [kW]	Qc max [kW]	Pin nom [kW]	Pin min [kW]	Pin max [kW]	EER kW / kW	Qh nom [kW]	Qh min [kW]	Qh max [kW]
40	27.6	13.8	27.6	13.3	6.5	13.3	2.08	39.9	20.0	39.9	25.7
39	28.1	14.0	28.1	13.0	6.4	13.0	2.16	40.1	20.1	40.1	25.4
38	28.6	14.3	28.6	12.7	6.3	12.7	2.24	40.4	20.2	40.4	25.1
37	29.0	14.5	29.0	12.5	6.1	12.5	2.32	40.6	20.3	40.6	24.9
36	29.5	14.7	29.5	12.2	6.0	12.2	2.41	40.8	20.4	40.8	24.6
35	29.9	15.0	29.9	12.0	5.9	12.0	2.49	41.1	20.5	41.1	24.3
34	30.4	15.2	30.4	11.8	5.8	11.8	2.58	41.3	20.7	41.3	24.1
33	30.8	15.4	30.8	11.5	5.7	11.5	2.67	41.6	20.8	41.6	23.8
32	31.3	15.6	31.3	11.3	5.6	11.3	2.76	41.8	20.9	41.8	23.6
31	31.7	15.9	31.7	11.1	5.5	11.1	2.86	42.0	21.0	42.0	23.4
30	32.2	16.1	32.2	10.9	5.4	10.9	2.95	42.3	21.1	42.3	23.2
29	32.6	16.3	32.6	10.7	5.3	10.7	3.05	42.5	21.3	42.5	23.0
28	33.0	16.5	33.0	10.5	5.2	10.5	3.15	42.8	21.4	42.8	22.8
27	33.4	16.7	33.4	10.3	5.1	10.3	3.25	43.0	21.5	43.0	22.6
26	33.9	16.9	33.9	10.1	5.0	10.1	3.35	43.2	21.6	43.2	22.4
25	34.3	17.1	34.3	9.9	4.9	9.9	3.45	43.5	21.7	43.5	22.2
24	34.7	17.3	34.7	9.8	4.8	9.8	3.56	43.7	21.9	43.7	22.0
23	35.1	17.5	35.1	9.6	4.7	9.6	3.66	44.0	22.0	44.0	21.9
22	35.5	17.7	35.5	9.4	4.6	9.4	3.77	44.2	22.1	44.2	21.7
21	35.9	17.9	35.9	9.2	4.5	9.2	3.88	44.4	22.2	44.4	21.6
20	36.3	18.1	36.3	9.1	4.5	9.1	4.00	44.7	22.3	44.7	21.4

Tc [°C]	W 23 / 18 °C										
	[°C]	Qc nom [kW]	Qc min [kW]	Qc max [kW]	Pin nom [kW]	Pin min [kW]	Pin max [kW]	EER kW / kW	Qh nom [kW]	Qh min [kW]	Qh max [kW]
40	42.9	21.4	42.9	13.3	6.5	13.3	3.23	55.3	27.6	51.4	25.9
39	43.5	21.7	43.5	13.0	6.4	13.0	3.34	55.7	27.8	51.8	25.6
38	44.1	22.1	44.1	12.7	6.3	12.7	3.46	56.1	28.0	52.2	25.3
37	44.7	22.4	44.7	12.5	6.1	12.5	3.58	56.5	28.2	52.6	25.0
36	45.4	22.7	45.4	12.2	6.0	12.2	3.70	56.9	28.4	53.0	24.8
35	46.0	23.0	46.0	12.0	5.9	12.0	3.83	57.3	28.6	53.3	24.5
34	46.6	23.3	46.6	11.8	5.8	11.8	3.95	57.6	28.8	53.7	24.3
33	47.2	23.6	47.2	11.5	5.7	11.5	4.08	58.0	29.0	54.1	24.0
32	47.7	23.9	47.7	11.3	5.6	11.3	4.22	58.4	29.2	54.5	23.8
31	48.3	24.2	48.3	11.1	5.5	11.1	4.35	58.8	29.4	54.9	23.6
30	48.9	24.5	48.9	10.9	5.4	10.9	4.49	59.2	29.6	55.3	23.4
29	49.5	24.7	49.5	10.7	5.3	10.7	4.63	59.6	29.8	55.7	23.2
28	50.0	25.0	50.0	10.5	5.2	10.5	4.77	60.0	30.0	56.1	23.0
27	50.6	25.3	50.6	10.3	5.1	10.3	4.91	60.3	30.2	56.5	22.8
26	51.2	25.6	51.2	10.1	5.0	10.1	5.06	60.7	30.4	56.9	22.6
25	51.7	25.9	51.7	9.9	4.9	9.9	5.21	61.1	30.5	57.3	22.4
24	52.2	26.1	52.2	9.8	4.8	9.8	5.36	61.5	30.7	57.6	22.2
23	52.8	26.4	52.8	9.6	4.7	9.6	5.51	61.8	30.9	58.0	22.0
22	53.3	26.7	53.3	9.4	4.6	9.4	5.67	62.2	31.1	58.4	21.9
21	53.8	26.9	53.8	9.2	4.5	9.2	5.83	62.6	31.3	58.8	21.7
20	54.3	27.2	54.3	9.1	4.5	9.1	5.99	62.9	31.5	59.2	21.6

-- Achtung: Betriebsgrenzen beachten - nicht in Tabelle festgehalten

LEGENDE:

Twq-RL: Temperatur Wärmequelle - Eintritt [°C]

Tws-VL: Temperatur Wärmesenke - Vorlauf [°C]

Tk-VL: Temperatur Kältesenke - Vorlauf [°C]

Qh nom: Heizleistung nominal

Qh min: Heizleistung minimal

Qh max: Heizleistung maximal

Pin nom: Aufnahme bei nominaler Heizleistung

Pin min: Aufnahme bei minimaler Heizleistung

Pin max: Aufnahme bei maximaler Heizleistung

COP nom: Arbeitszahl bei nominaler Heizleistung

Qc nom: Kälteleistung/Energieentnahme bei nominaler Heizleistung

Qc min: Kälteleistung/Energieentnahme bei minimaler Heizleistung

Qc max: Kälteleistung/Energieentnahme bei maximaler Heizleistung

I nom: Stromaufnahme bei nominaler Heizleistung

EER: Arbeitszahl bei nominaler Kälteleistung

Betriebsgrenzen

Temp °C

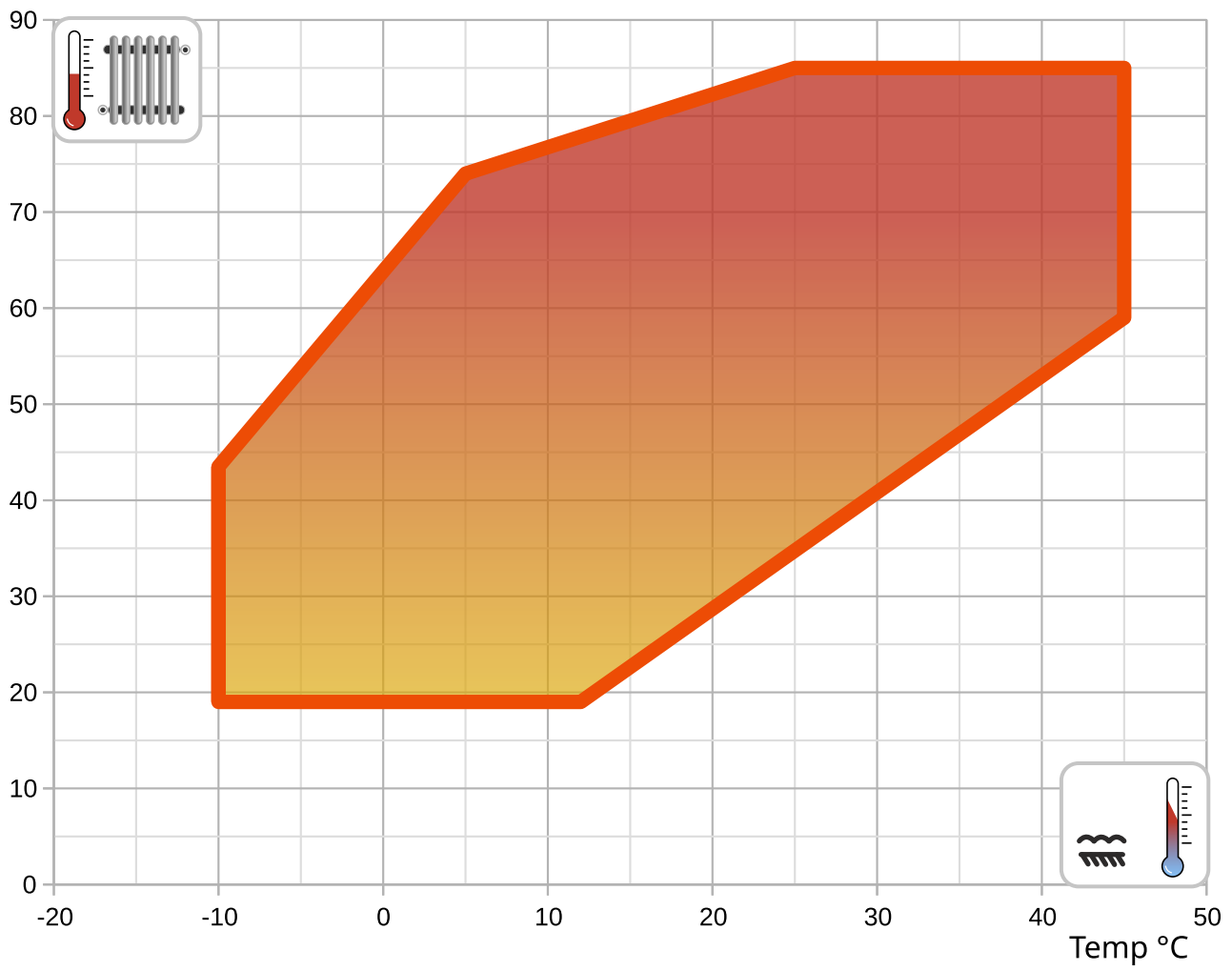

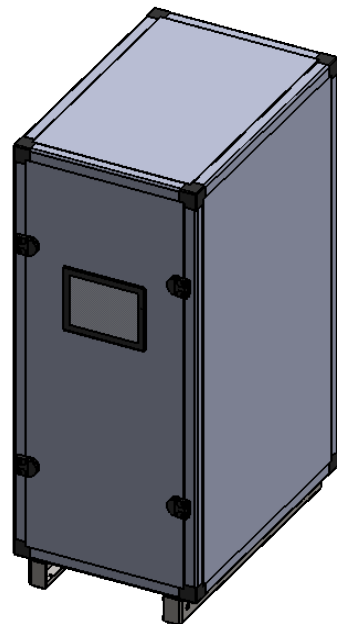
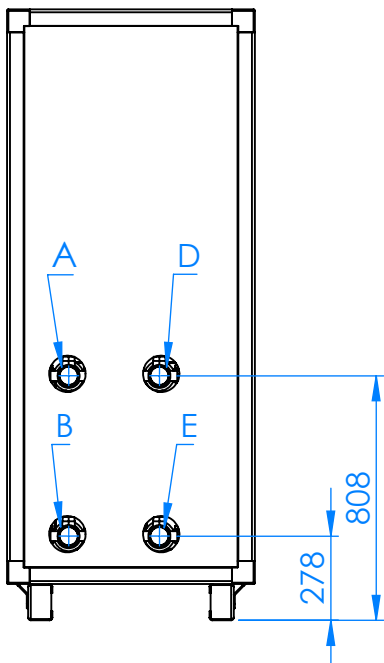
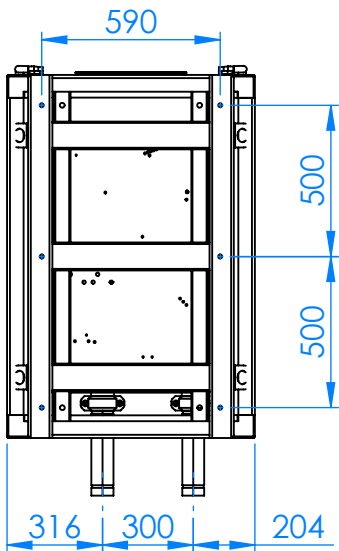
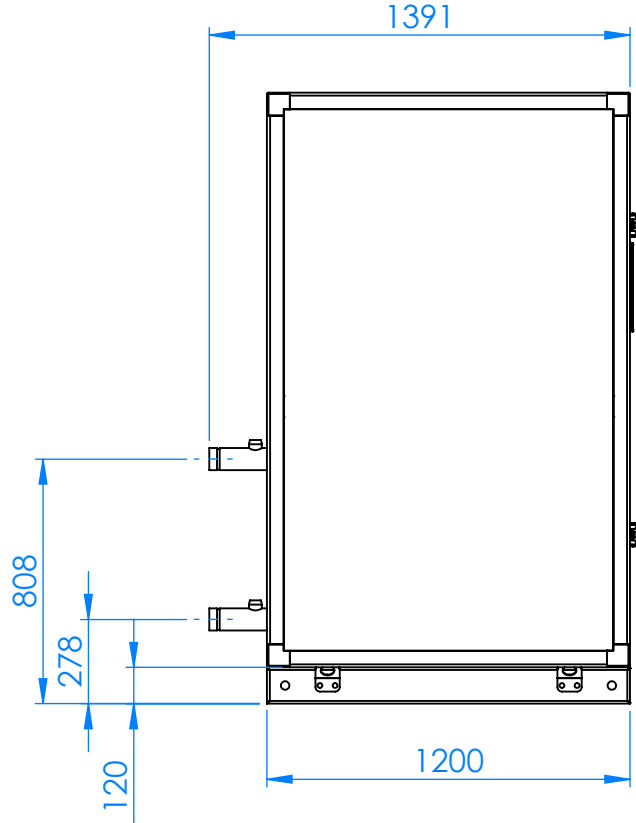
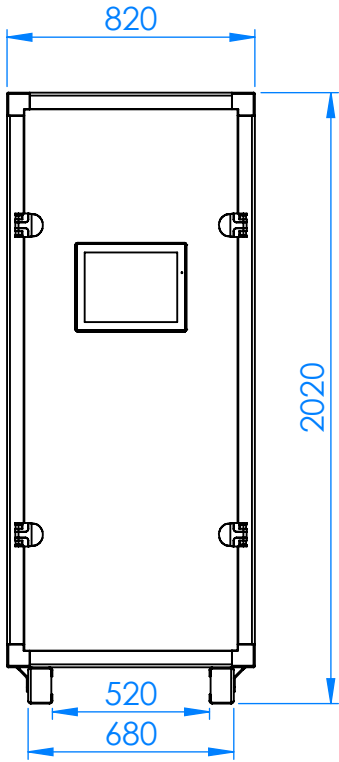

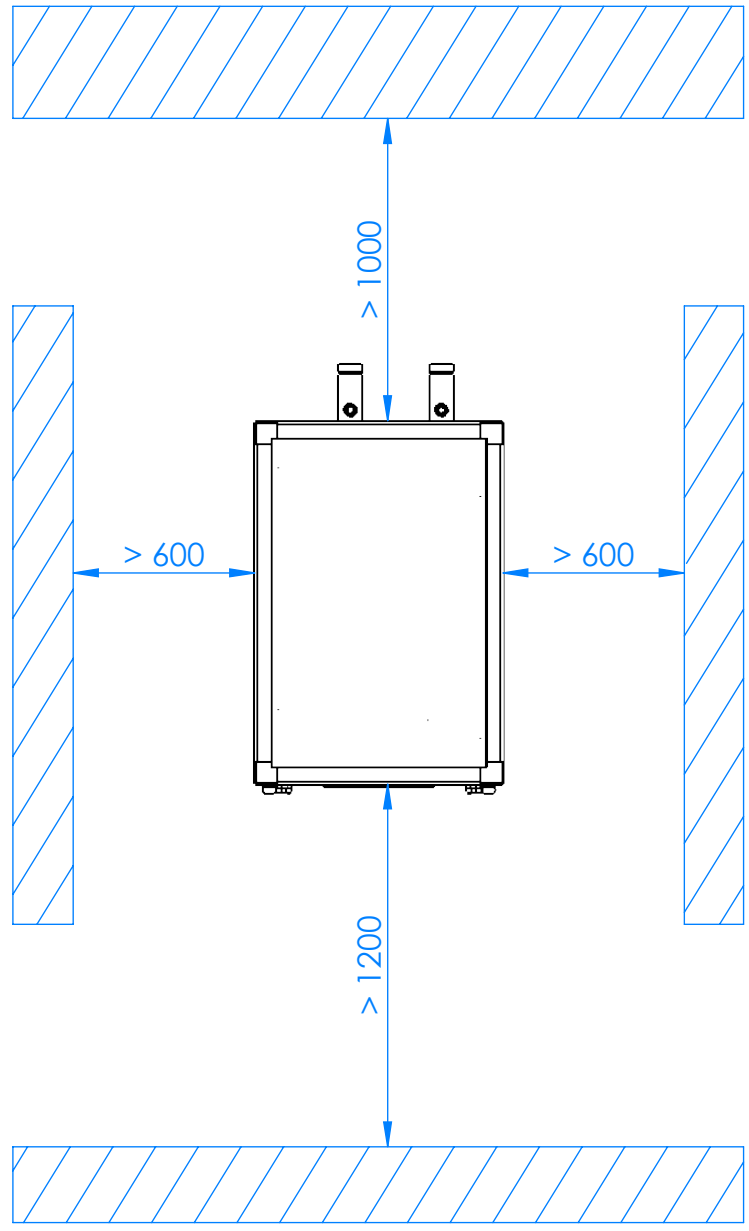

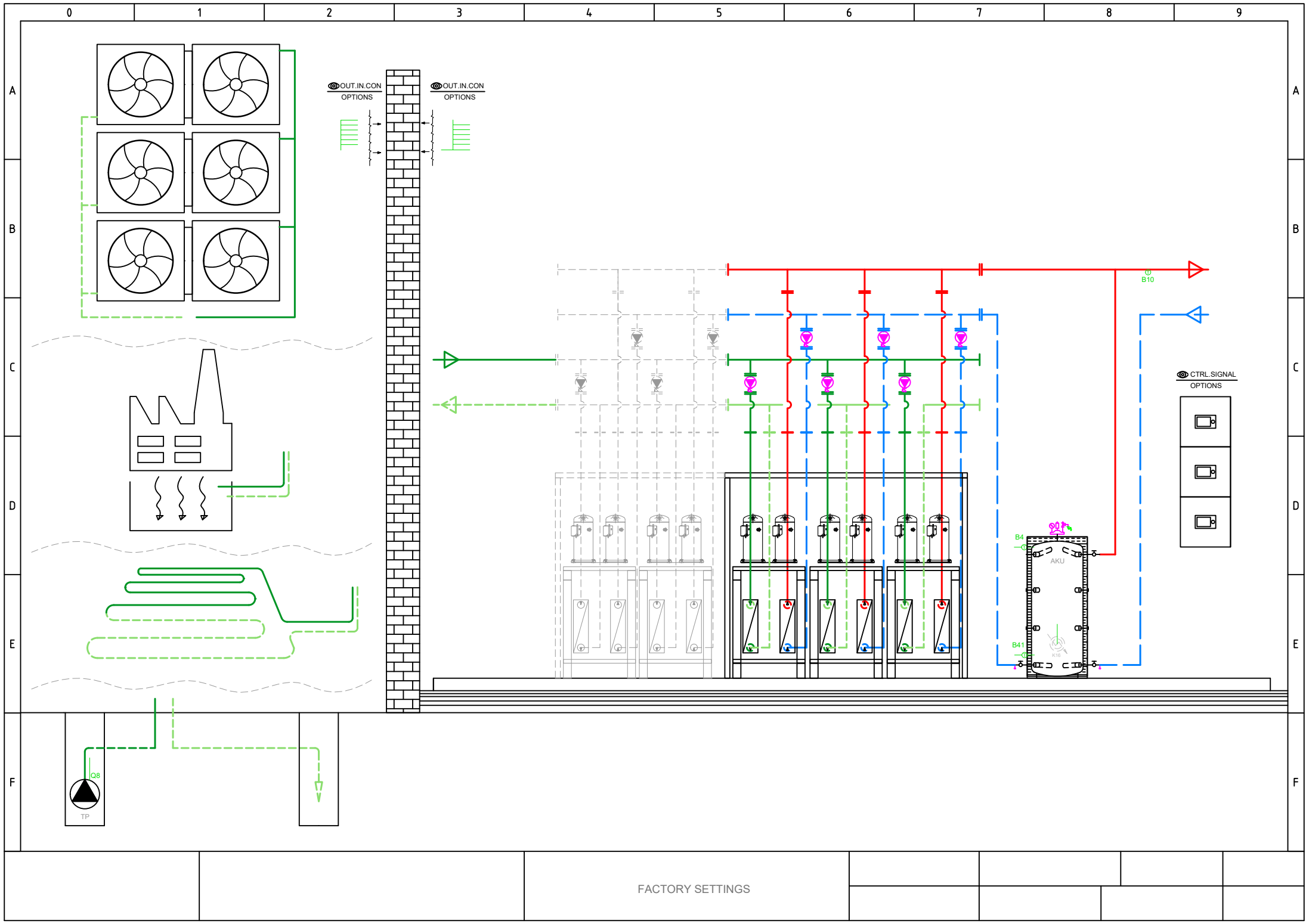

Total: max 6A
1 x QX...: max 2A

Netzanschluss 230V / 50 Hz
Erde
Nullleiter

- E9 Niederdruckwächter E9
- E10 Hochdruckwächter E10
- E15 Ström'wächter Quelle E15
- E24 Ström'wächter Verbrau E24
- E6 EW Sperre E6
- E12 Überlast Verdichter 2 E12
- E21 Drehstrom E21
- E22 Drehstrom E22
- E23 Drehstrom E23
- E11 Überlast Verdichter 1 E11
- K1 Verdichterstufe 1 K1

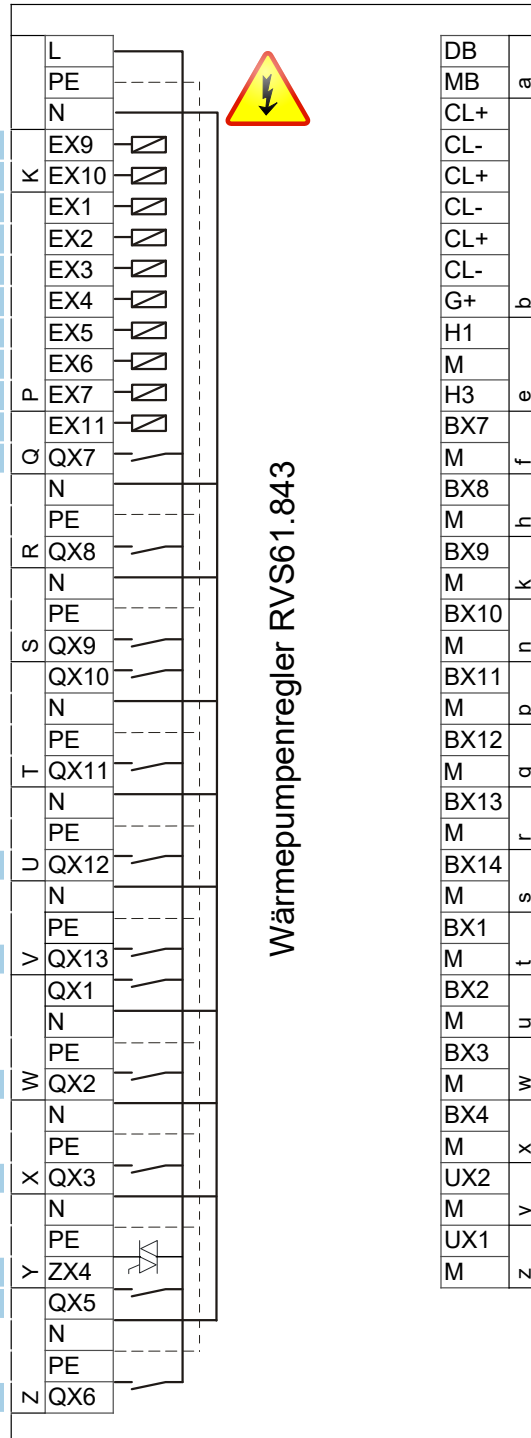

Wärmepumpenregler RVS61.843

Q8 Quellpumpe Q8

Q9 Kondensatorpumpe Q9

K10 Alarmausgang K10

K40 Ölumpfheizung K40

K81 Ventil Verdampfer K81

K82 Ventil EVI K82

K2 Verdichterstufe 2 K2

DB		LPB Bus Data
MB	a	LPB Bus Masse
CL+		Raumgerät QAA...
CL-		Raumgerät QAA... 2.
CL+		Raumgerät QAA... 2.
CL-		Raumgerät QAA... 2.
CL+		Raumgerät QAA... 3.
CL-		Raumgerät QAA... 3.
G+	b	12V Versorgung → AUS
H1		
M		
H3	e	Verbr'anforderung VK1
BX7		B81 Heissgasfühler K1 B81
M	f	
BX8		
M	h	
BX9		
M	k	
BX10		B21 WP Vorlauffühler B21
M	n	
BX11		
M	p	
BX12		B71 WP Rücklauffühler B71
M	q	
BX13		B91 Quelleneintrittfühler B91
M	r	
BX14		B84 Quellenaust'fühler B92/B84
M	s	
BX1		
M	t	
BX2		
M	u	
BX3		B83 Kältemittelfühler flüssig B83
M	w	
BX4		B82 Heissgasfühler K2 B82
M	x	
UX2		Kondensatorpumpe Q9
M	y	0..10V Analogsignal
UX1		Quell'pumpe Q8
M	z	0..10V Analogsignal



- AVS75.390
- AVS75.391
- AVS75.370

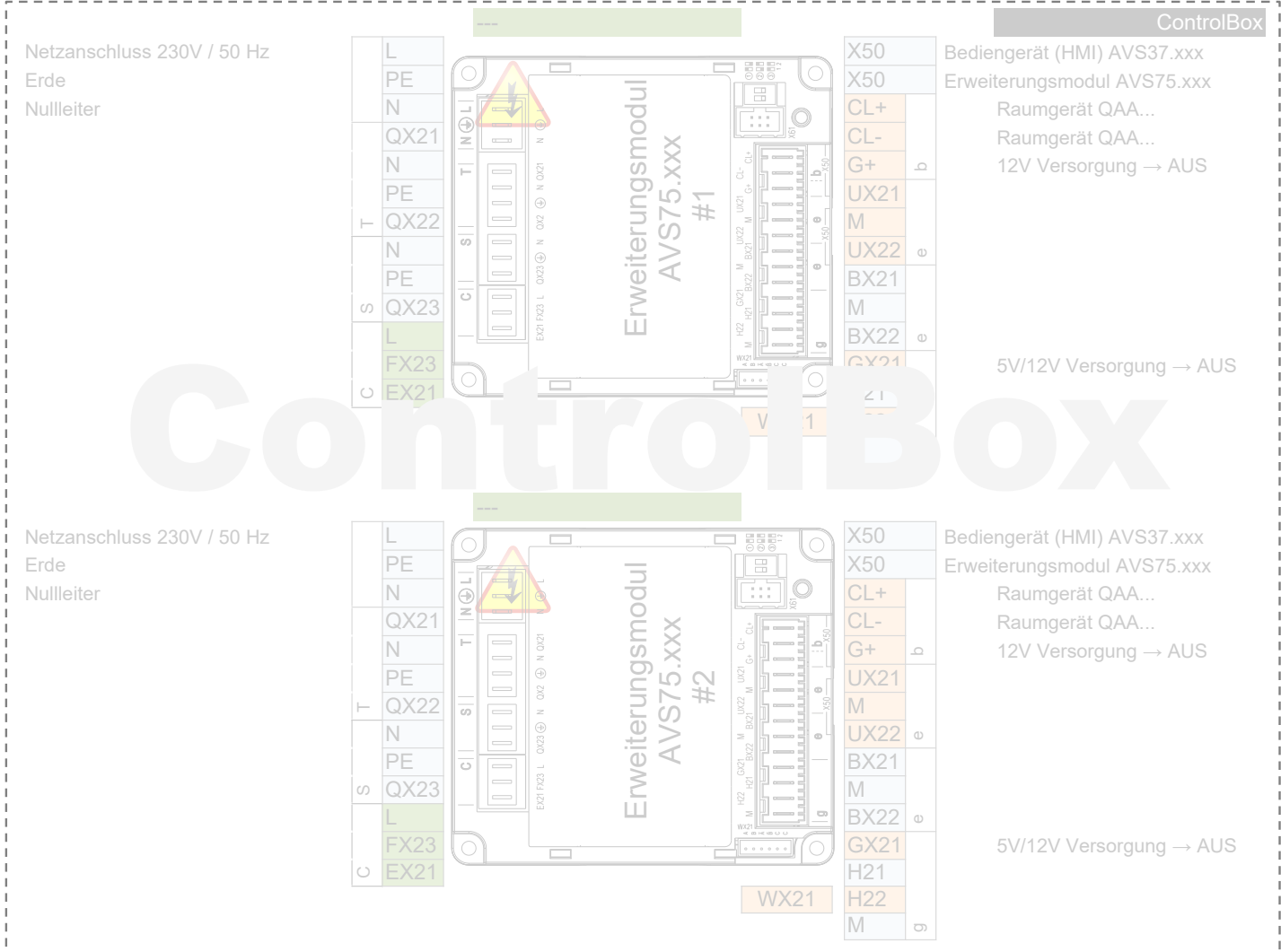

HEAT PUMP

EXTERNAL
INTERNAL

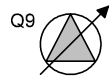
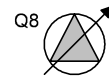

K1

K2

K82

K81

K40

K10

Q8 UX1

Q9 UX2

E11
KRW1
F1K
E11

E12
KRW2
F2K
E12

E6

Q9 ERR
F1S
E24

Q8 ERR
F1Z
E15

E10
E9

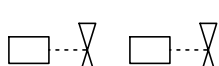

230V, 50Hz max 6A

0...10V



230V, 50Hz max 6A

0...10V

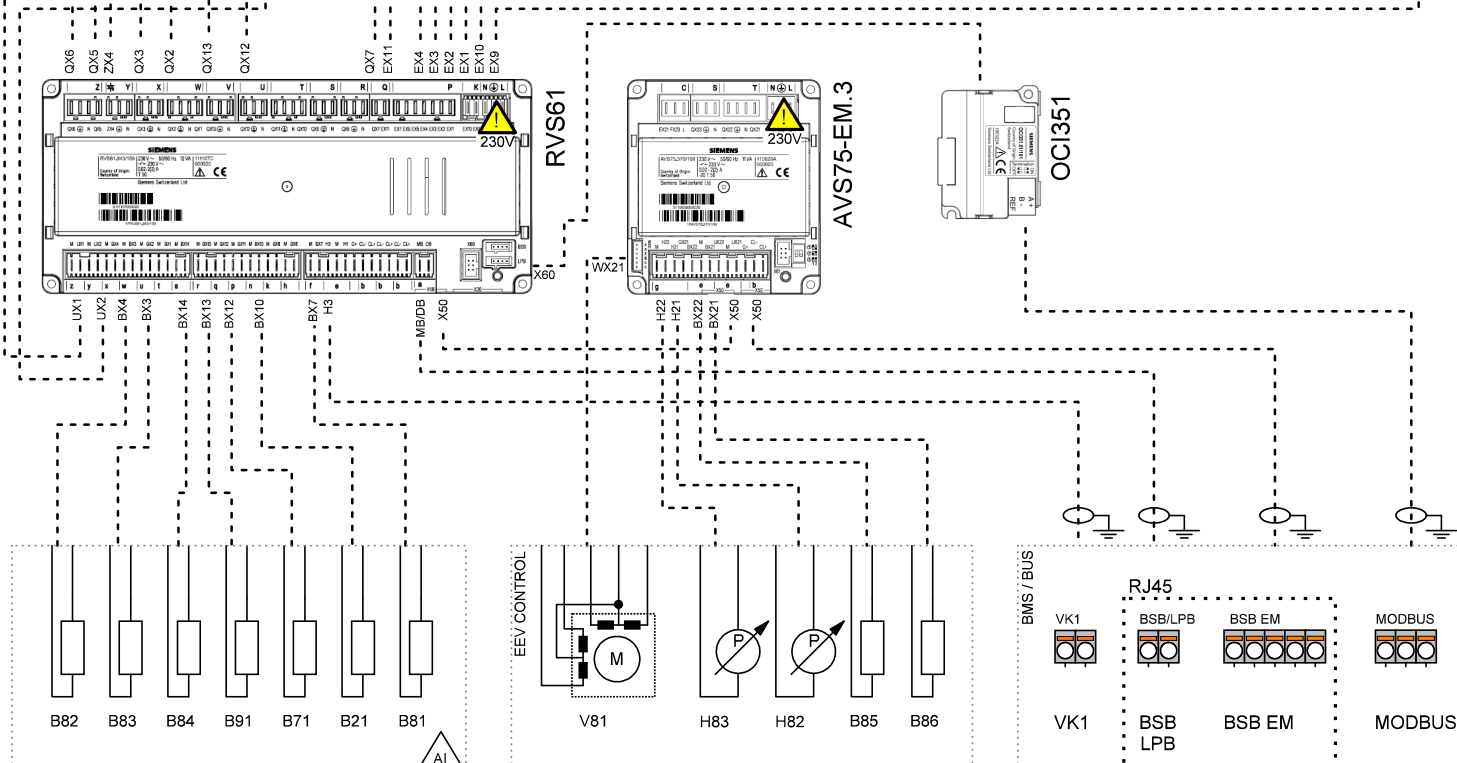
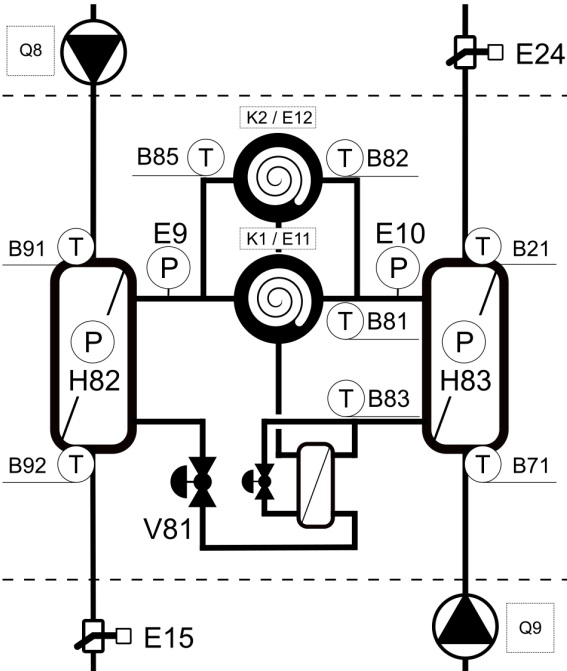

PWR SPLY: 3~ 400V, 50 Hz
CTRL: 1~ 230V, 50 HZ

Company	Title	Version / Note	Number	Created by	Date	Page
	TBW-TWW	05/2024				1



Company	Title	Version / Note	Number	Created by	Date	Page
	CONTROL BOX	05/2024				1



Company	Title	Version / Note	Number	Created by	Date	Page
	CONTROL BOX	05/2024				2



Company	Title	Version / Note	Number	Created by	Date	Page
	CONTROL BOX	05/2024				3



Company	Title	Version / Note	Number	Created by	Date	Page
	CONTROL BOX	05/2024				4



- AVS75.390
- AVS75.391
- AVS75.370

- AVS75.370**
 Netzanschluss 230V / 50 Hz
 Erde
 Nullleiter
Y1 Mischer Auf

Y2 Mischer Zu

Q2 Heizkreispumpe HK1 Q2

L Faze 230V
E61 Smart Grid E61

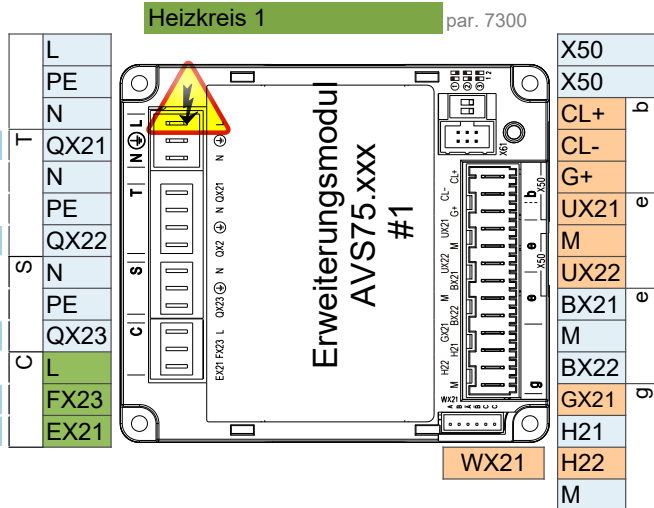

- Erweiterungsmodul AVS75.xxx
 Raumgerät QAA...
 Raumgerät QAA...

B1 Vorlauffühler 1

Impulszählung

- AVS75.370**
 Netzanschluss 230V / 50 Hz
 Erde
 Nullleiter
Q3 Trinkwasserstellglied Q3

K6 Elektroeinsatz TWW K6

Q6 Heizkreispumpe HK2 Q6

L Faze 230V
E62 Smart Grid E62

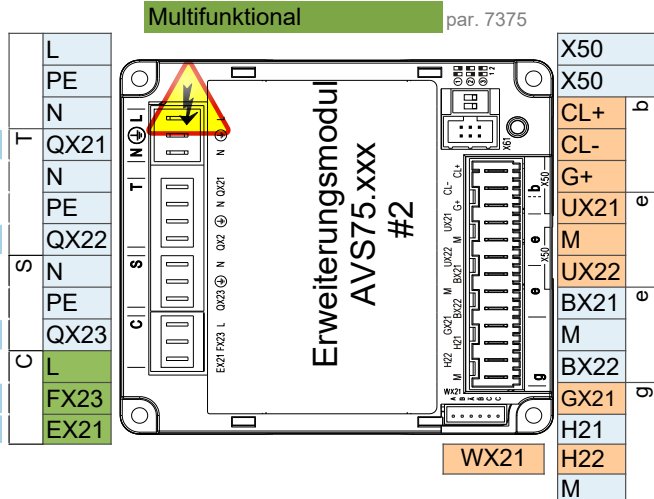

- Bediengerät (HMI) AVS37.xxx
 Erweiterungsmodul AVS75.xxx
 Raumgerät QAA...
 Raumgerät QAA...

B3 Trinkwasserfühler B3

B4 Pufferspeicherfühler B4

- Netzanschluss 230V / 50 Hz
 Erde
 Nullleiter

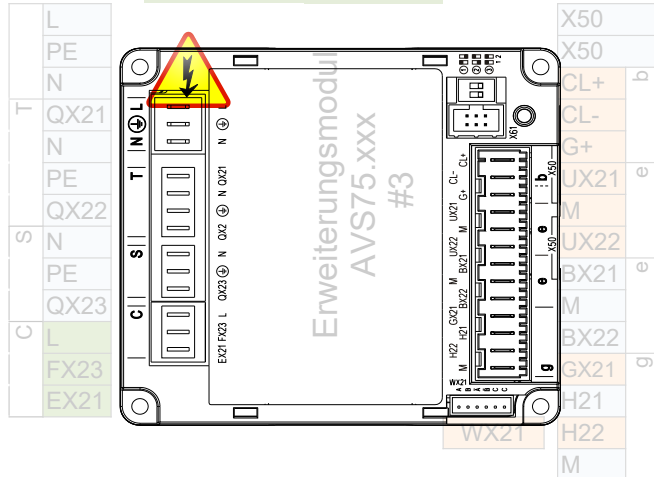

- Bediengerät (HMI) AVS37.xxx
 Erweiterungsmodul AVS75.xxx
 Raumgerät QAA...
 Raumgerät QAA...

Vorsicht: Erweiterungsmodul 3 ist in der Wärmepumpe

Anschlussmöglichkeiten für die Steuerung

1 ControlBox

ControlBox, mit zwei eingebauten Erweiterungsmodulen, ermöglicht zahlreiche Optionen für die Anwendungssteuerung auf der Verbraucherseite hinter der Wärmepumpe. Weitere Informationen finden Sie im Schaltplan der ControlBox und im Blatt mit den Anwendungsdiagrammen.

2 Fixer Sollwert Vorlauftemperatur - Ein / Aus potentialfreier Kontakt

2-adriges abgeschirmtes Kabel 2 x 0,5 mm² - Sollwert = 45°C (editierbar über Parameter 1859)

Anschlussklemme - siehe Schaltplan

3 Analog 0..10V Vorlauftemperatur-Sollwertregelung

2 Adern geschirmtes Kabel 2 x 0,5 mm² - Sollwert: 0V = 16°C ~ 10V = 60°C (editierbar im Parametersatz)

Anschlussklemme - siehe Schaltplan

4 ModBus RTU-Kommunikationsbefehl

3-adriges abgeschirmtes Kabel min. 3 x 0,25mm²

Für die ModBus-Zuordnungstabelle wenden Sie sich bitte an den technischen Support

5 MQTT IoT-Kommunikationsprotokoll

Für weitere Informationen wenden Sie sich bitte an den technischen Support