

Základné údaje o výkone - WAMAK AW 400 EVI HeavyDuty 2L4

Vykurovanie - EN 14511		
Tepelný výkon [kW]	A7 / W35	392.7 (49.1 / 392.7)
	A2 / W35	333.6 (41.7 / 333.6)
	A-7 / W34	279.9 (35.0 / 279.9)
Elektrický príkon [kW]	A7 / W35	91.1 (10.7 / 91.1)
	A2 / W35	91.0 (10.7 / 91.0)
	A-7 / W34	88.4 (10.3 / 88.4)
Tepelná účinnosť [COP]	A7 / W35	4.31
	A2 / W35	3.67
	A-7 / W34	3.17
Sezónna tepelná účinnosť vykurovania - SCOP EN 14825		
Stredná klim. zóna / Nízka teplota [35°C]	SCOP	4.24
	η [%]	169.5
	Label	A+++
	Qhe [kWh]	154395.0
	Pdesignh [kW]	317.4
	Tbivalent [°C]	-7
Chladenie		
Chladiaci výkon - [kW]	A35 / W23-18	387.4
	A25 / W23-18	407.2
	A35 / W12-7	291.0
	A25 / W12-7	291.0
Sezónna účinnosť chladenia - SEER EN 14825		
[W 23 / 18°C]	SEER	4.55
	Qce [kWh]	174600.0
	η_c [%]	182.1
Zvuk EN 12102		
Zvuk - výkon - Lw	dB(A)	75.2
Zvuk - tlak - Lp	1 m dB(A)	67.2
	5 m dB(A)	53.2
	10 m dB(A)	47.2
Strojné a prevádzkové informácie		
Typ kompresoru (3~ 400/50)	SCROLL / 8 /	Zap/Vyp
Chladivo	R410A (GWP - 2088)	8 x 9.6 kg
Prevádzkové hraničné teploty vykurovania - (min / max) [°C]		25 / 65
Prevádzkové hraničné teploty zdroja - (min / max) [°C]		-22 / 40
Váha zariadenia		1980 kg

Hlavné technické údaje - WAMAK AW 400 EVI HeavyDuty 2L4

Označenie krytovania		HD2L4		Údaje strany odovzdania tepelnej energie		
Základné rozmery	Výška [mm]	2000		Prevádzkové hraničné teploty vykurovania	MAX [°C]	65
	Šírka [mm]	2800			MIN [°C]	25
	Dĺžka [mm]	1200		viac vid. diagram prevádzkových limitov		
Váha zariadenia [kg]	1980		Kondenzátor	Pripojovacia dimenzia	8 x 2 "	
Farba krytovania	Sivá			Typ	BPHE	
IP trieda krytovania	IP20			Počet	8	
				Materiál	AISI 316	
Chladivový okruh				Maximálny prevádzkový tlak - chladivo [bar]	50	
Kompresor	Typ	Scroll		Maximálny prevádzkový tlak - Voda [bar]	6	
	Výkonové stupňe	8		Testovací pretlak [bar]	70	
	Zap/Vyp			Teplonosné médium	Voda	
	Účinník Cosφ	0.64		Objemový prietok @ dT 5K (nom) - Voda [m3/h]	8.48 ~ 67.81	
	Odpor vynutia kompresora	0.76 Ohm		Vnútorná tlaková strata - Voda [kPa]	8 x 20	
Chladivo		R410A		Teplotný spád @ 35°C (nom)	5 K	
	Objem	8 x 9.6 kg		@ 55°C	8 K	
	GWP	2088		@ 65°C	10 K	
	Bezpečnostná trieda	A1				
Typ oleja v okruhu	POE RL32-3MAF			Údaje strany odberu obnoviteľnej energie		
	Objem oleja	8 x 3.38 L		Prevádzkové hraničné teploty zdroja	MIN [°C]	-22
Maximálny tlak chladiva [bar]		50			MAX [°C]	40
	PED trieda	2		viac vid. diagram prevádzkových limitov		
EVI - vstrek chladiva s ekonomizérom			Výparník	Pripojovacia dimenzia	8 x (7/8" - 1.3/8") "	
APS systém podchladenia chladiva				Typ	Cu-coil /Al-fin	
Reverzibilný chod (chladenie)				Počet	8	
Reverzibilné odtavenie horúcimi parami				Materiál	Cu/Al	
Ochrana doskového výmenníka horúcimi parami HG-BYPASS			Maximálny prevádzkový tlak - chladivo [bar]	29		
Údaje elektrického pripojenia			Teplonosné médium	Vzduch		
Elektro napájanie [#~ V/Hz]	3~ 400/50		Objemový prietok - Vzduch [m3/h]	15073 ~ 120580		
Prúd	nominálny [A]	188.24		Vnútorná tlaková strata - Vzduch [kPa]	8 x 0.061	
	maximálny [A]	299.20		Teplotný spád - Vzduch	7 K	
	štartovací [A]	57.2		Možné vonkajšie jednotky	4 x VOV900X2-FRAME	
Softštartér	-		8 x VOII-1200-2LOW			
Hlavný istič - charakteristika	C300		8 x VOII-1200-2HIGH			
			8 x VOII-1200-2LOW-DUCT			
			8 x VOII-1200-2HIGH-DUCT			
Riadiaci systém			Slit systém (kompresor v interieri)			
Hlavný regulátor	SIEMENS	RVS 21 AVS 55.199		Dimenzia tekutinové potrubie (do 8 metrov VN/VO)	8 x 7/8"	
Rozširovací modul	AVS75.3xx	AVS75.3xx	AVS75.372	Dimenzia sacie potrubie (do 8 metrov VN/VO)	8 x 1.3/8"	
Bus Clip-In		LPB OCI345	Modbus OCI351	Náplň nad 8 metrov dĺžky prepoja	8 x 0.35 kg/m	
Online pripojenie		Web server OZW672	ToSyMo	pri Split systémoch je vnútorná jednotka TC predplnená iba minimálnym pretlakom chladiva ktoré ostalo v systéme po funkčnej skúške.		
Regulácia EEV	SEC61					

*** s príslušenstvom

WAMAK AW 400 EVI HeavyDuty 2L4

ErP (EU) No 811/2013: Technické parametre vykurovacích zariadení s tepelným čerpadlom

Model	AW 400 EVI HeavyDuty 2L4
Tepelné čerpadlo vzduch-voda	áno
Tepelné čerpadlo soľanka-voda	nie
Tepelné čerpadlo voda-voda	nie
Nízkotepelné tepelné čerpadlo	nie
Vybavené prídavným ohrievačom	nie
Kombinované tepelné čerpadlo s ohrievačom	nie
Teplotné použitie	nízka teplota (35 °C - 30 °C)
Klimatická oblasť	priemerná

Položka	Symbol	Hodnota	mj	Položka	Symbol	Hodnota	mj
Menovitý tepelný výkon pri Tdesignh	Prated	317.4	kW	Sezónna energetická účinnosť vykurovania priestoru	η_s	169.5	%
Deklarovaný výkon vykurovania pri čiastočnom zaťažení pri vnútornej teplote 20 °C a vonkajšej teplote Tj				Deklarovaný súčiniteľ výkonu alebo pomer primárnej energie pre čiastočné zaťaženie pri vnútornej teplote 20 °C a vonkajšej teplote Tj			
Tj = -7 °C	Pdh	279.9	kW	Tj = -7 °C	COPd	3.17	-
Tj = +2 °C	Pdh	330.0	kW	Tj = +2 °C	COPd	4.1	-
Tj = +7 °C	Pdh	388.7	kW	Tj = +7 °C	COPd	5.1	-
Tj = +12 °C	Pdh	459.6	kW	Tj = +12 °C	COPd	6.4	-
Tj = bivalentná teplota	Pdh	275.2	kW	Tj = bivalentná teplota	COPd	3.1	-
Tj = hraničná prevádzková teplota	Pdh	200.7	kW	Tj = hraničná prevádzková teplota	COPd	2.3	-
Bivalentná teplota	Tbiv	-7	°C	Tj = hraničná prevádzková teplota	TOL	-22	°C
Spotreba energie v iných ako aktívnych režimoch				Medzná prevádzková teplota vykurovacej vody	WTOL	65	°C
Vypnuté	Poff	0.040	kW	Prídavný ohrievač			
Režim vypnutia termostatu	Pto	0.010	kW	Menovitý tepelný výkon	Psup	140.7	kW
Pohotovostný režim	Psb	0.010	kW	Typ príkonu energie	elektrická		
Režim ohrevu kľukovej skrine	Pck	0.050	kW				
Ostatné položky							
Regulácia výkonu	viacero stupňov			Pre tepelné čerpadlá vzduch-voda: Menovitý prietok vzduchu, vonku	-	15073 ~ 120580	m ³ /h
Úroveň akustického výkonu				Pre tepelné čerpadlá voda-voda alebo soľanka-voda: Menovitý prietok soľanky alebo vody, vonkajší výmenník tepla	-	---	m ³ /h
v interiéri	Lwa	75	dB				
vonku	Lwa	80	dB				
Ročná spotreba energie	Q _{HE}	154395.0	kWh				

Kontaktné údaje: WAMAK, s.r.o., Orovnica 252, 96652, Orovnica, Slovakia, info@wamak.sk

WAMAK AW 400 EVI HeavyDuty 2L4

ErP (EU) No 811/2013: Technické parametre vykurovacích zariadení s tepelným čerpadlom

Model	AW 400 EVI HeavyDuty 2L4
Tepelné čerpadlo vzduch-voda	áno
Tepelné čerpadlo soľanka-voda	nie
Tepelné čerpadlo voda-voda	nie
Nízkoteplotné tepelné čerpadlo	nie
Vybavené prídavným ohrievačom	nie
Kombinované tepelné čerpadlo s ohrievačom	nie
Teplotné použitie	stredá teplota (55°C - 47°C)
Klimatická oblasť	priemerná

Položka	Symbol	Hodnota	mj	Položka	Symbol	Hodnota	mj
Menovitý tepelný výkon pri Tdesignh	Prated	333.0	kW	Sezónna energetická účinnosť vykurovania priestoru	η_s	132.6	%
Deklarovaný výkon vykurovania pri čiastočnom zaťažení pri vnútornej teplote 20 °C a vonkajšej teplote Tj				Deklarovaný súčiniteľ výkonu alebo pomer primárnej energie pre čiastočné zaťaženie pri vnútornej teplote 20 °C a vonkajšej teplote Tj			
Tj = -7 °C	Pdh	292.6	kW	Tj = -7 °C	COPd	2.24	-
Tj = +2 °C	Pdh	338.0	kW	Tj = +2 °C	COPd	3.2	-
Tj = +7 °C	Pdh	393.1	kW	Tj = +7 °C	COPd	4.2	-
Tj = +12 °C	Pdh	460.5	kW	Tj = +12 °C	COPd	5.6	-
Tj = bivalentná teplota	Pdh	289.1	kW	Tj = bivalentná teplota	COPd	2.1	-
Tj = hraničná prevádzková teplota	Pdh	211.6	kW	Tj = hraničná prevádzková teplota	COPd	1.6	-
Bivalentná teplota	Tbiv	-7	°C	Tj = hraničná prevádzková teplota	TOL	-22	°C
Spotreba energie v iných ako aktívnych režimoch				Medzná prevádzková teplota vykurovacej vody	WTOL	65	°C
Vypnuté	Poff	0.040	kW	Prídavný ohrievač			
Režim vypnutia termostatu	Pto	0.010	kW	Menovitý tepelný výkon	Psup	140.7	kW
Pohotovostný režim	Psb	0.010	kW	Typ príkonu energie	elektrická		
Režim ohrevu kľukovej skrine	Pck	0.050	kW				
Ostatné položky							
Regulácia výkonu	viacero stupňov			Pre tepelné čerpadlá vzduch-voda: Menovitý prietok vzduchu, vonku	-	15073 ~ 120580	m3/h
Úroveň akustického výkonu				Pre tepelné čerpadlá voda-voda alebo soľanka-voda: Menovitý prietok soľanky alebo vody, vonkajší výmenník tepla	-	---	m3/h
v interiéri	Lwa	75	dB				
vonku	Lwa	80	dB				
Ročná spotreba energie	QHE	207204.4	kWh				

Kontaktné údaje: WAMAK, s.r.o., Orovnica 252, 96652, Orovnica, Slovakia, info@wamak.sk



ENERG Y IIA
 енергия - ενεργεια IE IA



AW 400 EVI

HeavyDuty 2L4

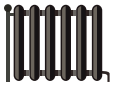

55 °C

35 °C

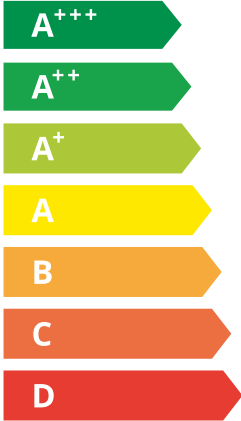

75 dB

80 dB

■ 350	■ 324
■ 333	■ 318
■ 327	■ 302
kW	kW

2019

811/2013

AW 400 EVI HeavyDuty
2L4

ErP Data

	55 °C	35 °C
Energy class	A++	A+++
η [%]	132.6	169.5
P_{rated} [kW]	333	318
Q_{HE} [kWh/y]	207205	154395
SCOP [-]	3.31	4.24
$T_{bivalent}$ [°C]	-7	-7

CONTROLLER



+ QAA55/75 class VII 3.5% ↓
 - QAA55/75 class III 1.5% ↓

Tepelný výkon - prevádzkové dáta

Version: v2024.004-AW

Stredná klim. zóna / Nízka teplota [35°C]

ZHI46K1P-TWD_R410A_8_AW

Prevádzkové podmienky	Qh	P	COP
1 A7 / W30-35	392.7	91.1	4.31
2 A2 / W35	333.6	91.0	3.67
3 A-22 / W35	200.7	86.7	2.31
A A-7 / W34	279.9	88.4	3.17
B A2 / W30	330.0	81.3	4.06
C A7 / W27	388.7	76.1	5.11
D A12 / W24	459.6	71.7	6.41
E A-10 / W35	275.2	90.2	3.05
F A-7 / W34	279.9	88.4	3.17

SCOP DATA EN 14825:2018	
Stredná klim. zóna / Nízka teplota [35°C]	
SCOPon	4.25
SCOPnet	4.29
SCOP	4.24
η [%]	169.48
Label	A+++
Qh [kWh]	655748.40
Pdesignh [kW]	317.4
Tbivalent [°C]	-7.00

Stredná klim. zóna / Stredná teplota [55°C]

Prevádzkové podmienky	Qh	P	COP
1 A7 / W47-55	400.7	142.8	2.81
2 A2 / W55	345.7	141.8	2.44
3 A-22 / W55	211.6	121.3	1.62
A A-7 / W52	292.6	130.6	2.24
B A2 / W42	338.0	106.1	3.18
C A7 / W36	393.1	93.1	4.22
D A12 / W30	460.5	81.7	5.64
E A-10 / W55	289.1	139.1	2.08
F A-7 / W55	294.5	139.5	2.11

SCOP DATA EN 14825:2018	
Stredná klim. zóna / Stredná teplota [55°C]	
SCOPon	3.32
SCOPnet	3.34
SCOP	3.31
η [%]	132.57
Label	A++
Qh [kWh]	687978.00
Pdesignh [kW]	333.0
Tbivalent [°C]	-7.00

Chladiaci výkon - prevádzkové dáta

Nízkoteplotné chladenie W 12 / 7°C

Prevádzkové podmienky	Qc	P	EER
A A35 / W12-7	291.0	108.7	2.68
B A30 / W12-7	299.1	97.3	3.07
C A25 / W12-7	305.9	87.1	3.51
D A20 / W12-7	311.5	77.8	4.00

SEER DATA EN 14825:2018 [W 12 / 7°C]	
SEERon	3.43
SEER	3.42
Qc [kWh]	174600.00
η [%]	136.86

Plošné chladenie W 23 / 18°C

Prevádzkové podmienky	Qc	P	EER
A A35 / W23-18	387.4	108.7	3.56
B A30 / W23-18	398.0	90.1	4.09
C A25 / W23-18	407.2	80.9	4.67
D A20 / W23-18	415.3	72.8	5.34

SEER DATA EN 14825:2018 [W 23 / 18°C]	
SEERon	4.57
SEER	4.55
Qc [kWh]	174600.00
η [%]	182.09

Výkonové kryvky - vykurovanie

- Qh-nom-35 — Qh-min-35 - - - Qh-max-65 — Qh-nom-45 — Qh-nom-55
- Qh-nom-65 — Pratedh-35 — Pratedh-55

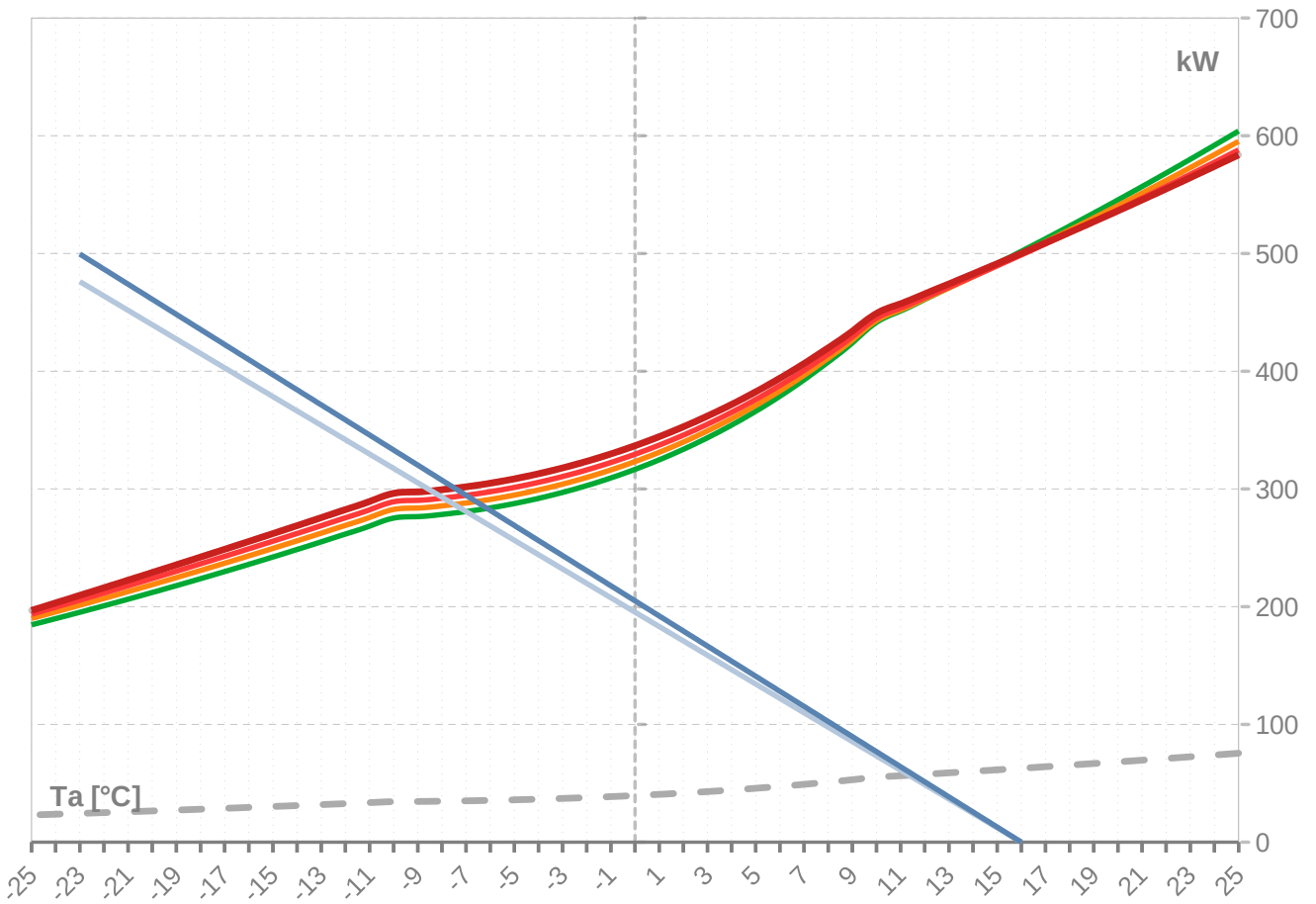

Výkonové kryvky - chladenie

- Pratedc — Qc-12/7 — Qc-23/18

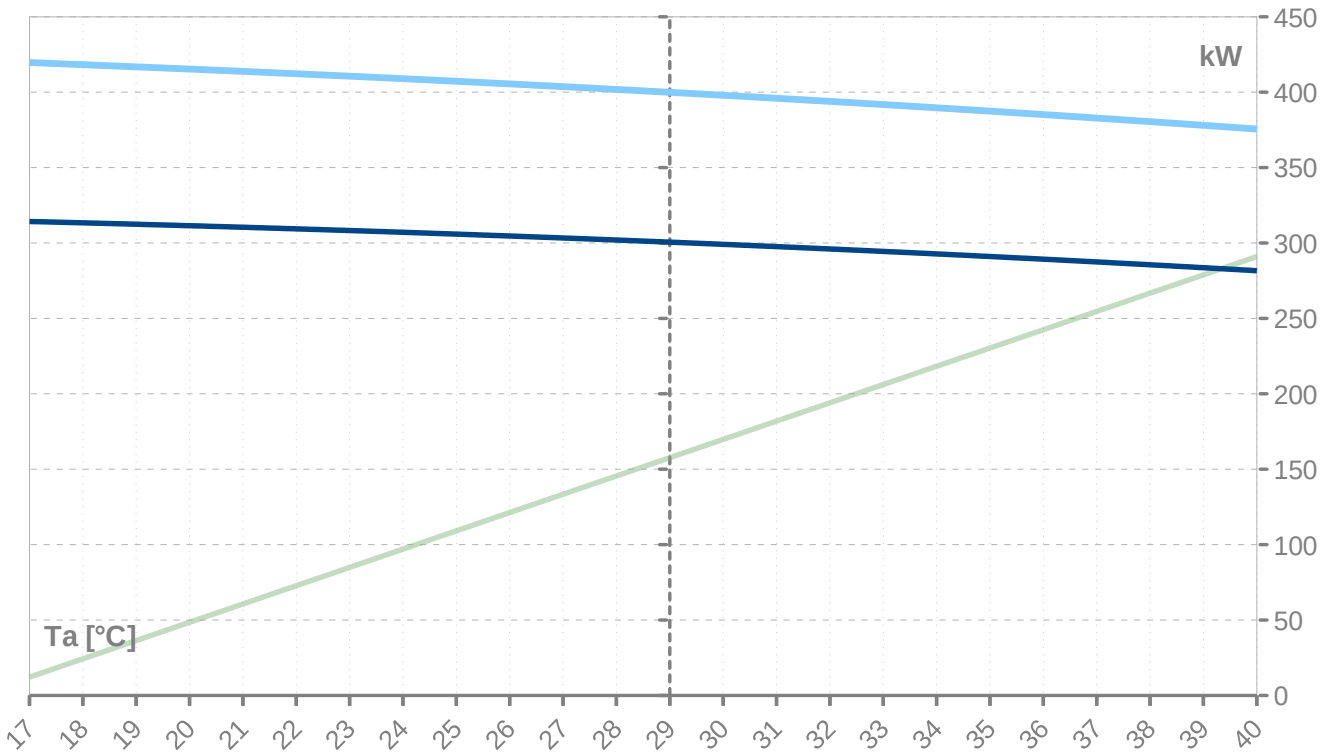

Th [°C]		35 °C								
Ta [°C]	Qh nom [kW]	Qh min [kW]	Qh max [kW]	Pin nom [kW]	Pin-min [kW]	Pin-max [kW]	COP kW / kW	I nom [A]	I min [A]	I max [A]
25	512.5	64.1		91.1	10.7		5.62	186.2	23.3	
24	512.5	64.1		91.1	10.7		5.62	186.2	23.3	
23	512.5	64.1		91.1	10.7		5.62	186.2	23.3	
22	512.5	64.1		91.1	10.7		5.62	186.2	23.3	
21	512.5	64.1		91.1	10.7		5.62	186.2	23.3	
20	512.5	64.1		91.1	10.7		5.62	186.2	23.3	
19	512.5	64.1		91.1	10.7		5.62	186.2	23.3	
18	512.5	64.1		91.1	10.7		5.62	186.2	23.3	
17	512.5	64.1		91.1	10.7		5.62	186.2	23.3	
16	501.8	62.7	501.8	91.1	10.7	91.1	5.51	186.3	23.3	186.3
15	491.4	61.4	491.4	91.1	10.7	91.1	5.40	186.5	23.3	186.5
14	481.1	60.1	481.1	91.1	10.7	91.1	5.28	186.6	23.3	186.6
13	470.9	58.9	470.9	91.0	10.7	91.0	5.17	186.8	23.4	186.8
12	460.9	57.6	460.9	91.0	10.7	91.0	5.06	187.0	23.4	187.0
11	451.1	56.4	451.1	91.0	10.7	91.0	4.96	187.2	23.4	187.2
10	441.5	55.2	441.5	91.0	10.7	91.0	4.85	187.4	23.4	187.4
9	424.0	53.0	424.0	91.1	10.7	91.1	4.66	187.8	23.5	187.8
8	407.8	51.0	407.8	91.1	10.7	91.1	4.48	188.2	23.5	188.2
7	392.7	49.1	392.7	91.1	10.7	91.1	4.31	188.6	23.6	188.6
6	378.8	47.3	378.8	91.1	10.7	91.1	4.16	188.9	23.6	188.9
5	366.0	45.7	366.0	91.1	10.7	91.1	4.02	189.2	23.7	189.2
4	354.2	44.3	354.2	91.0	10.7	91.0	3.89	189.4	23.7	189.4
3	343.4	42.9	343.4	91.0	10.7	91.0	3.77	189.6	23.7	189.6
2	333.6	41.7	333.6	91.0	10.7	91.0	3.67	189.8	23.7	189.8
1	324.7	40.6	324.7	90.9	10.6	90.9	3.57	189.9	23.7	189.9
0	316.6	39.6	316.6	90.8	10.6	90.8	3.49	190.0	23.7	190.0
-1	309.3	38.7	309.3	90.8	10.6	90.8	3.41	190.0	23.7	190.0
-2	302.8	37.9	302.8	90.7	10.6	90.7	3.34	190.0	23.7	190.0
-3	297.0	37.1	297.0	90.6	10.6	90.6	3.28	190.0	23.7	190.0
-4	292.0	36.5	292.0	90.5	10.6	90.5	3.22	189.9	23.7	189.9
-5	287.6	35.9	287.6	90.5	10.6	90.5	3.18	189.9	23.7	189.9
-6	283.8	35.5	283.8	90.4	10.6	90.4	3.14	189.8	23.7	189.8
-7	280.8	35.1	280.8	90.3	10.6	90.3	3.11	189.8	23.7	189.8
-8	278.3	34.8	278.3	90.3	10.6	90.3	3.08	189.7	23.7	189.7
-9	276.5	34.6	276.5	90.2	10.6	90.2	3.06	189.7	23.7	189.7
-10	275.2	34.4	275.2	90.2	10.6	90.2	3.05	189.7	23.7	189.7
-11	268.4	33.5	268.4	90.1	10.5	90.1	2.98	189.5	23.7	189.5
-12	261.6	32.7	261.6	89.9	10.5	89.9	2.91	189.3	23.7	189.3
-13	255.0	31.9	255.0	89.7	10.5	89.7	2.84	189.0	23.6	189.0
-14	248.5	31.1	248.5	89.4	10.5	89.4	2.78	188.6	23.6	188.6
-15	242.2	30.3	242.2	89.2	10.4	89.2	2.72	188.3	23.5	188.3
-16	235.9	29.5	235.9	88.9	10.4	88.9	2.65	187.8	23.5	187.8
-17	229.8	28.7	229.8	88.6	10.4	88.6	2.59	187.3	23.4	187.3
-18	223.7	28.0	223.7	88.3	10.3	88.3	2.53	186.8	23.3	186.8
-19	217.8	27.2	217.8	87.9	10.3	87.9	2.48	186.2	23.3	186.2
-20	212.0	26.5	212.0	87.6	10.3	87.6	2.42	185.5	23.2	185.5
-21	206.3	25.8	206.3	87.1	10.2	87.1	2.37	184.7	23.1	184.7
-22	200.7	25.1	200.7	86.7	10.2	86.7	2.31	183.9	23.0	183.9
-23	195.2	24.4	195.2	86.2	10.1	86.2	2.26	183.0	22.9	183.0
-24	189.8	23.7	189.8	85.7	10.0	85.7	2.21	182.0	22.8	182.0
-25	184.5	23.1	184.5	85.2	10.0	85.2	2.17	181.0	22.6	181.0

* pozor: pracovný rozsah nie je zohľadnený v tabuľke

ZHI46K1P-TWD_R410A_8_AW

Th [°C]		45 °C								
Ta [°C]	Qh nom [kW]	Qh min [kW]	Qh max [kW]	Pin nom [kW]	Pin-min [kW]	Pin-max [kW]	COP kW / kW	I nom [A]	I min [A]	I max [A]
25	595.2	74.4	595.2	112.9	13.2	112.9	5.27	212.2	26.5	212.2
24	584.0	73.0	584.0	112.9	13.2	112.9	5.17	212.2	26.5	212.2
23	572.9	71.6	572.9	112.9	13.2	112.9	5.07	212.2	26.5	212.2
22	562.0	70.2	562.0	113.0	13.2	113.0	4.98	212.2	26.5	212.2
21	551.2	68.9	551.2	113.0	13.2	113.0	4.88	212.2	26.5	212.2
20	540.6	67.6	540.6	113.0	13.2	113.0	4.78	212.2	26.5	212.2
19	530.2	66.3	530.2	113.1	13.2	113.1	4.69	212.3	26.5	212.3
18	519.9	65.0	519.9	113.1	13.2	113.1	4.60	212.3	26.5	212.3
17	509.8	63.7	509.8	113.2	13.3	113.2	4.50	212.4	26.6	212.4
16	499.8	62.5	499.8	113.3	13.3	113.3	4.41	212.5	26.6	212.5
15	490.0	61.2	490.0	113.3	13.3	113.3	4.32	212.6	26.6	212.6
14	480.3	60.0	480.3	113.4	13.3	113.4	4.24	212.7	26.6	212.7
13	470.7	58.8	470.7	113.4	13.3	113.4	4.15	212.8	26.6	212.8
12	461.3	57.7	461.3	113.5	13.3	113.5	4.07	212.9	26.6	212.9
11	452.1	56.5	452.1	113.5	13.3	113.5	3.98	212.9	26.6	212.9
10	443.0	55.4	443.0	113.6	13.3	113.6	3.90	213.0	26.6	213.0
9	426.4	53.3	426.4	113.6	13.3	113.6	3.75	213.1	26.6	213.1
8	411.0	51.4	411.0	113.7	13.3	113.7	3.62	213.2	26.7	213.2
7	396.6	49.6	396.6	113.7	13.3	113.7	3.49	213.2	26.7	213.2
6	383.3	47.9	383.3	113.7	13.3	113.7	3.37	213.2	26.7	213.2
5	371.0	46.4	371.0	113.7	13.3	113.7	3.26	213.1	26.6	213.1
4	359.7	45.0	359.7	113.6	13.3	113.6	3.17	213.0	26.6	213.0
3	349.3	43.7	349.3	113.5	13.3	113.5	3.08	212.8	26.6	212.8
2	339.8	42.5	339.8	113.4	13.3	113.4	3.00	212.6	26.6	212.6
1	331.1	41.4	331.1	113.3	13.3	113.3	2.92	212.3	26.5	212.3
0	323.2	40.4	323.2	113.1	13.2	113.1	2.86	212.0	26.5	212.0
-1	316.1	39.5	316.1	113.0	13.2	113.0	2.80	211.7	26.5	211.7
-2	309.7	38.7	309.7	112.8	13.2	112.8	2.74	211.4	26.4	211.4
-3	304.1	38.0	304.1	112.7	13.2	112.7	2.70	211.1	26.4	211.1
-4	299.1	37.4	299.1	112.5	13.2	112.5	2.66	210.8	26.4	210.8
-5	294.8	36.8	294.8	112.4	13.2	112.4	2.62	210.5	26.3	210.5
-6	291.1	36.4	291.1	112.3	13.1	112.3	2.59	210.3	26.3	210.3
-7	288.0	36.0	288.0	112.2	13.1	112.2	2.57	210.0	26.3	210.0
-8	285.6	35.7	285.6	112.1	13.1	112.1	2.55	209.8	26.2	209.8
-9	283.8	35.5	283.8	112.0	13.1	112.0	2.53	209.7	26.2	209.7
-10	282.6	35.3	282.6	112.0	13.1	112.0	2.52	209.6	26.2	209.6
-11	275.7	34.5	275.7	111.7	13.1	111.7	2.47	209.0	26.1	209.0
-12	269.0	33.6	269.0	111.4	13.0	111.4	2.42	208.3	26.0	208.3
-13	262.4	32.8	262.4	111.0	13.0	111.0	2.36	207.6	25.9	207.6
-14	255.9	32.0	255.9	110.6	13.0	110.6	2.31	206.8	25.8	206.8
-15	249.5	31.2	249.5	110.2	12.9	110.2	2.26	205.9	25.7	205.9
-16	243.1	30.4	243.1	109.8	12.9	109.8	2.21	205.0	25.6	205.0
-17	236.9	29.6	236.9	109.3	12.8	109.3	2.17	204.0	25.5	204.0
-18	230.7	28.8	230.7	108.8	12.7	108.8	2.12	202.9	25.4	202.9
-19	224.7	28.1	224.7	108.3	12.7	108.3	2.07	201.7	25.2	201.7
-20	218.7	27.3	218.7	107.7	12.6	107.7	2.03	200.5	25.1	200.5
-21	212.8	26.6	212.8	107.1	12.5	107.1	1.99	199.1	24.9	199.1
-22	207.0	25.9	207.0	106.4	12.5	106.4	1.94	197.7	24.7	197.7
-23	201.2	25.2	201.2	105.8	12.4	105.8	1.90	196.3	24.5	196.3
-24	195.6	24.4	195.6	105.0	12.3	105.0	1.86	194.7	24.3	194.7
-25	190.0	23.7	190.0	104.2	12.2	104.2	1.82	193.0	24.1	193.0

* pozor: pracovný rozsah nie je zohľadnený v tabuľke

WAMAK AW 400 EVI HeavyDuty 2L4

Th [°C]		55 °C								
Ta [°C]	Qh nom [kW]	Qh min [kW]	Qh max [kW]	Pin nom [kW]	Pin-min [kW]	Pin-max [kW]	COP kW / kW	I nom [A]	I min [A]	I max [A]
25	588.0	73.5	588.0	141.8	16.6	141.8	4.15	245.2	30.7	245.2
24	577.5	72.2	577.5	141.9	16.6	141.9	4.07	245.3	30.7	245.3
23	567.2	70.9	567.2	142.0	16.6	142.0	3.99	245.4	30.7	245.4
22	557.0	69.6	557.0	142.1	16.6	142.1	3.92	245.4	30.7	245.4
21	547.0	68.4	547.0	142.2	16.6	142.2	3.85	245.5	30.7	245.5
20	537.1	67.1	537.1	142.3	16.7	142.3	3.77	245.6	30.7	245.6
19	527.3	65.9	527.3	142.4	16.7	142.4	3.70	245.7	30.7	245.7
18	517.7	64.7	517.7	142.5	16.7	142.5	3.63	245.8	30.7	245.8
17	508.1	63.5	508.1	142.5	16.7	142.5	3.56	245.9	30.7	245.9
16	498.8	62.3	498.8	142.6	16.7	142.6	3.50	245.9	30.7	245.9
15	489.5	61.2	489.5	142.7	16.7	142.7	3.43	246.0	30.8	246.0
14	480.4	60.0	480.4	142.8	16.7	142.8	3.36	246.1	30.8	246.1
13	471.3	58.9	471.3	142.8	16.7	142.8	3.30	246.1	30.8	246.1
12	462.4	57.8	462.4	142.9	16.7	142.9	3.24	246.2	30.8	246.2
11	453.7	56.7	453.7	142.9	16.7	142.9	3.17	246.2	30.8	246.2
10	445.0	55.6	445.0	142.9	16.7	142.9	3.11	246.2	30.8	246.2
9	429.3	53.7	429.3	142.9	16.7	142.9	3.00	246.1	30.8	246.1
8	414.5	51.8	414.5	142.9	16.7	142.9	2.90	246.0	30.7	246.0
7	400.7	50.1	400.7	142.8	16.7	142.8	2.81	245.8	30.7	245.8
6	387.9	48.5	387.9	142.7	16.7	142.7	2.72	245.5	30.7	245.5
5	376.0	47.0	376.0	142.5	16.7	142.5	2.64	245.1	30.6	245.1
4	365.1	45.6	365.1	142.3	16.7	142.3	2.57	244.7	30.6	244.7
3	355.0	44.4	355.0	142.1	16.6	142.1	2.50	244.2	30.5	244.2
2	345.7	43.2	345.7	141.8	16.6	141.8	2.44	243.7	30.5	243.7
1	337.2	42.1	337.2	141.5	16.6	141.5	2.38	243.1	30.4	243.1
0	329.4	41.2	329.4	141.2	16.5	141.2	2.33	242.5	30.3	242.5
-1	322.4	40.3	322.4	141.0	16.5	141.0	2.29	241.9	30.2	241.9
-2	316.1	39.5	316.1	140.7	16.5	140.7	2.25	241.4	30.2	241.4
-3	310.5	38.8	310.5	140.4	16.4	140.4	2.21	240.8	30.1	240.8
-4	305.6	38.2	305.6	140.1	16.4	140.1	2.18	240.3	30.0	240.3
-5	301.3	37.7	301.3	139.9	16.4	139.9	2.15	239.8	30.0	239.8
-6	297.6	37.2	297.6	139.7	16.4	139.7	2.13	239.3	29.9	239.3
-7	294.5	36.8	294.5	139.5	16.3	139.5	2.11	238.9	29.9	238.9
-8	292.1	36.5	292.1	139.3	16.3	139.3	2.10	238.6	29.8	238.6
-9	290.3	36.3	290.3	139.2	16.3	139.2	2.09	238.4	29.8	238.4
-10	289.1	36.1	289.1	139.1	16.3	139.1	2.08	238.2	29.8	238.2
-11	282.2	35.3	282.2	138.7	16.2	138.7	2.04	237.2	29.7	237.2
-12	275.5	34.4	275.5	138.1	16.2	138.1	1.99	236.2	29.5	236.2
-13	268.8	33.6	268.8	137.6	16.1	137.6	1.95	235.0	29.4	235.0
-14	262.1	32.8	262.1	137.0	16.0	137.0	1.91	233.8	29.2	233.8
-15	255.6	31.9	255.6	136.4	16.0	136.4	1.87	232.5	29.1	232.5
-16	249.1	31.1	249.1	135.7	15.9	135.7	1.84	231.2	28.9	231.2
-17	242.7	30.3	242.7	135.0	15.8	135.0	1.80	229.7	28.7	229.7
-18	236.4	29.5	236.4	134.2	15.7	134.2	1.76	228.1	28.5	228.1
-19	230.1	28.8	230.1	133.4	15.6	133.4	1.72	226.5	28.3	226.5
-20	223.9	28.0	223.9	132.6	15.5	132.6	1.69	224.8	28.1	224.8
-21	217.7	27.2	217.7	131.7	15.4	131.7	1.65	222.9	27.9	222.9
-22	211.6	26.4	211.6	130.8	15.3	130.8	1.62	221.0	27.6	221.0
-23	205.5	25.7	205.5	129.8	15.2	129.8	1.58	219.0	27.4	219.0
-24	199.5	24.9	199.5	128.8	15.1	128.8	1.55	216.8	27.1	216.8
-25	193.6	24.2	193.6	127.7	15.0	127.7	1.52	214.6	26.8	214.6

* pozor: pracovný rozsah nie je zohľadnený v tabuľke

WAMAK AW 400 EVI HeavyDuty 2L4

Th [°C]		T-Max @ 65 °C								
Ta [°C]	Qh nom [kW]	Qh min [kW]	Qh max [kW]	Pin nom [kW]	Pin-min [kW]	Pin-max [kW]	COP kW / kW	I nom [A]	I min [A]	I max [A]
25	583.7	73.0	583.7	180.8	21.2	180.8	3.23	289.1	36.1	289.1
24	574.0	71.8	574.0	180.9	21.2	180.9	3.17	289.3	36.2	289.3
23	564.4	70.5	564.4	181.0	21.2	181.0	3.12	289.5	36.2	289.5
22	554.9	69.4	554.9	181.1	21.2	181.1	3.06	289.8	36.2	289.8
21	545.5	68.2	545.5	181.2	21.2	181.2	3.01	290.0	36.2	290.0
20	536.2	67.0	536.2	181.3	21.2	181.3	2.96	290.2	36.3	290.2
19	527.0	65.9	527.0	181.3	21.2	181.3	2.91	290.3	36.3	290.3
18	517.9	64.7	517.9	181.4	21.2	181.4	2.86	290.5	36.3	290.5
17	509.0	63.6	509.0	181.4	21.2	181.4	2.81	290.6	36.3	290.6
16	500.1	62.5	500.1	181.5	21.2	181.5	2.76	290.8	36.3	290.8
15	491.4	61.4	491.4	181.5	21.2	181.5	2.71	290.9	36.4	290.9
14	482.7	60.3	482.7	181.5	21.3	181.5	2.66	291.0	36.4	291.0
13	474.1	59.3	474.1	181.5	21.2	181.5	2.61	291.0	36.4	291.0
12	465.7	58.2	465.7	181.4	21.2	181.4	2.57	291.1	36.4	291.1
11	457.3	57.2	457.3	181.4	21.2	181.4	2.52	291.1	36.4	291.1
10	449.0	56.1	449.0	181.3	21.2	181.3	2.48	291.1	36.4	291.1
9	434.0	54.2	434.0	181.1	21.2	181.1	2.40	290.9	36.4	290.9
8	419.8	52.5	419.8	180.9	21.2	180.9	2.32	290.7	36.3	290.7
7	406.5	50.8	406.5	180.6	21.1	180.6	2.25	290.3	36.3	290.3
6	394.0	49.3	394.0	180.2	21.1	180.2	2.19	289.8	36.2	289.8
5	382.5	47.8	382.5	179.8	21.1	179.8	2.13	289.2	36.2	289.2
4	371.8	46.5	371.8	179.4	21.0	179.4	2.07	288.6	36.1	288.6
3	361.9	45.2	361.9	178.9	21.0	178.9	2.02	287.9	36.0	287.9
2	352.7	44.1	352.7	178.4	20.9	178.4	1.98	287.1	35.9	287.1
1	344.4	43.0	344.4	177.9	20.8	177.9	1.94	286.3	35.8	286.3
0	336.7	42.1	336.7	177.5	20.8	177.5	1.90	285.5	35.7	285.5
-1	329.7	41.2	329.7	177.0	20.7	177.0	1.86	284.7	35.6	284.7
-2	323.4	40.4	323.4	176.5	20.7	176.5	1.83	283.9	35.5	283.9
-3	317.8	39.7	317.8	176.0	20.6	176.0	1.81	283.1	35.4	283.1
-4	312.8	39.1	312.8	175.6	20.6	175.6	1.78	282.4	35.3	282.4
-5	308.5	38.6	308.5	175.2	20.5	175.2	1.76	281.8	35.2	281.8
-6	304.8	38.1	304.8	174.9	20.5	174.9	1.74	281.2	35.1	281.2
-7	301.8	37.7	301.8	174.6	20.4	174.6	1.73	280.7	35.1	280.7
-8	299.3	37.4	299.3	174.3	20.4	174.3	1.72	280.2	35.0	280.2
-9	297.5	37.2	297.5	174.1	20.4	174.1	1.71	279.9	35.0	279.9
-10	296.2	37.0	296.2	174.0	20.4	174.0	1.70	279.7	35.0	279.7
-11	289.3	36.2	289.3	173.3	20.3	173.3	1.67	278.4	34.8	278.4
-12	282.4	35.3	282.4	172.5	20.2	172.5	1.64	277.0	34.6	277.0
-13	275.6	34.4	275.6	171.6	20.1	171.6	1.61	275.5	34.4	275.5
-14	268.8	33.6	268.8	170.8	20.0	170.8	1.57	273.9	34.2	273.9
-15	262.0	32.8	262.0	169.8	19.9	169.8	1.54	272.3	34.0	272.3
-16										
-17										
-18										
-19										
-20										
-21										
-22										
-23										
-24										
-25										

* pozor: pracovný rozsah nie je zohľadnený v tabuľke

WAMAK AW 400 EVI HeavyDuty 2L4

Tc [°C]		W 12 / 7 °C								
Ta [°C]	Qc nom [kW]	Qc min [kW]	Qc max [kW]	Pin [kW]	Pin min [kW]	Pin max [kW]	EER kW / kW	I nom [A]	I min [A]	I max [A]
40	281.6	281.6	281.6	121.6	113.9	121.6	2.32	221.9	221.9	221.9
39	283.6	283.6	283.6	118.9	111.4	118.9	2.38	218.9	218.9	218.9
38	285.6	285.6	285.6	116.3	108.9	116.3	2.46	216.0	216.0	216.0
37	287.4	287.4	287.4	113.7	106.5	113.7	2.53	213.2	213.2	213.2
36	289.3	289.3	289.3	111.2	104.2	111.2	2.60	210.5	210.5	210.5
35	291.0	291.0	291.0	108.7	101.9	108.7	2.68	207.8	207.8	207.8
34	292.8	292.8	292.8	106.3	99.6	106.3	2.75	205.3	205.3	205.3
33	294.4	294.4	294.4	104.0	97.4	104.0	2.83	202.7	202.7	202.7
32	296.0	296.0	296.0	101.7	95.3	101.7	2.91	200.3	200.3	200.3
31	297.6	297.6	297.6	99.5	93.2	99.5	2.99	197.9	197.9	197.9
30	299.1	299.1	299.1	97.3	91.2	97.3	3.07	195.5	195.5	195.5
29	300.6	300.6	300.6	95.2	89.2	95.2	3.16	193.2	193.2	193.2
28	302.0	302.0	302.0	93.1	87.2	93.1	3.24	191.0	191.0	191.0
27	303.3	303.3	303.3	91.1	85.3	91.1	3.33	188.8	188.8	188.8
26	304.6	304.6	304.6	89.1	83.4	89.1	3.42	186.6	186.6	186.6
25	305.9	305.9	305.9	87.1	81.6	87.1	3.51	184.5	184.5	184.5
24	307.1	307.1	307.1	85.2	79.8	85.2	3.60	182.4	182.4	182.4
23	308.3	308.3	308.3	83.3	78.0	83.3	3.70	180.3	180.3	180.3
22	309.4	309.4	309.4	81.4	76.3	81.4	3.80	178.3	178.3	178.3
21	310.4	310.4	310.4	79.6	74.6	79.6	3.90	176.2	176.2	176.2
20	311.5	311.5	311.5	77.8	72.9	77.8	4.00	174.2	174.2	174.2
19	312.4	312.4	312.4	76.0	71.2	76.0	4.11	172.2	172.2	172.2
18	313.4	313.4	313.4	74.3	69.6	74.3	4.22	170.2	170.2	170.2
17	314.3	314.3	314.3	72.6	68.0	72.6	4.33	168.2	168.2	168.2

Tc [°C]		W 23 / 18 °C								
Ta [°C]	Qc [kW]	Qh-min [kW]	Qh-max [kW]	Pin [kW]	Pin-min [kW]	Pin-max [kW]	EER kW / kW	I [A]	I-min [A]	I-max [A]
40	375.5	375.5	375.5	121.6	113.9	121.6	3.09	221.7	221.7	221.7
39	378.0	378.0	378.0	118.9	111.4	118.9	3.18	218.6	218.6	218.6
38	380.5	380.5	380.5	116.3	108.9	116.3	3.27	215.6	215.6	215.6
37	382.8	382.8	382.8	113.7	106.5	113.7	3.37	212.6	212.6	212.6
36	385.2	385.2	385.2	111.2	104.2	111.2	3.46	209.8	209.8	209.8
35	387.4	387.4	387.4	108.7	101.9	108.7	3.56	207.0	207.0	207.0
34	389.6	389.6	389.6	106.3	99.6	106.3	3.66	204.2	204.2	204.2
33	391.8	391.8	391.8	104.0	97.4	104.0	3.77	201.6	201.6	201.6
32	393.9	393.9	393.9	101.7	95.3	101.7	3.87	199.0	199.0	199.0
31	396.0	396.0	396.0	99.5	93.2	99.5	3.98	196.4	196.4	196.4
30	398.0	398.0	398.0	97.3	91.2	97.3	4.09	193.9	193.9	193.9
29	399.9	399.9	399.9	95.2	89.2	95.2	4.20	191.4	191.4	191.4
28	401.8	401.8	401.8	93.1	87.2	93.1	4.32	189.0	189.0	189.0
27	403.7	403.7	403.7	91.1	85.3	91.1	4.43	186.6	186.6	186.6
26	405.5	405.5	405.5	89.1	83.4	89.1	4.55	184.2	184.2	184.2
25	407.2	407.2	407.2	87.1	81.6	87.1	4.67	181.9	181.9	181.9
24	408.9	408.9	408.9	85.2	79.8	85.2	4.80	179.6	179.6	179.6
23	410.6	410.6	410.6	83.3	78.0	83.3	4.93	177.3	177.3	177.3
22	412.2	412.2	412.2	81.4	76.3	81.4	5.06	175.0	175.0	175.0
21	413.8	413.8	413.8	79.6	74.6	79.6	5.20	172.8	172.8	172.8
20	415.3	415.3	415.3	77.8	72.9	77.8	5.34	170.5	170.5	170.5
19	416.8	416.8	416.8	76.0	71.2	76.0	5.48	168.3	168.3	168.3
18	418.2	418.2	418.2	74.3	69.6	74.3	5.63	166.0	166.0	166.0
17	419.6	419.6	419.6	72.6	68.0	72.6	5.78	163.8	163.8	163.8

* pozor: pracovný rozsah nie je zohľadnený v tabuľke

LEGENDE:

Tz-VS: Teplota zdroja - vstup [°C]

Tv-VY: Teplota vykurovania - výstup [°C]

Tch-VY: Teplota chladenia - výstup [°C]

Qh nom: Nominálny tepelný výkon

Qh min: Minimálny tepelný výkon

Qh max: Maxmálny tepelný výkon

Pin nom: Príkonnosť pri nominálnom tepelnom výkone

Pin min: Príkonnosť pri minimálnom tepelnom výkone

Pin max: Príkonnosť pri maximálnom tepelnom výkone

COP nom: Koeficient účinnosti pri nominálnom tepelnom výkone

Qc nom: Chladiaci výkon / odobrané teplo pri nominálnom tepelnom výkone

Qc min: Chladiaci výkon / odobrané teplo pri minimálnom tepelnom výkone

Qc max: Chladiaci výkon / odobrané teplo pri maximálnom tepelnom výkone

I nom: Prúd pri nominálnom tepelnom výkone

EER: Koeficient účinnosti pri nominálnom chladiacom výkone

Prevádzkové limity

°C

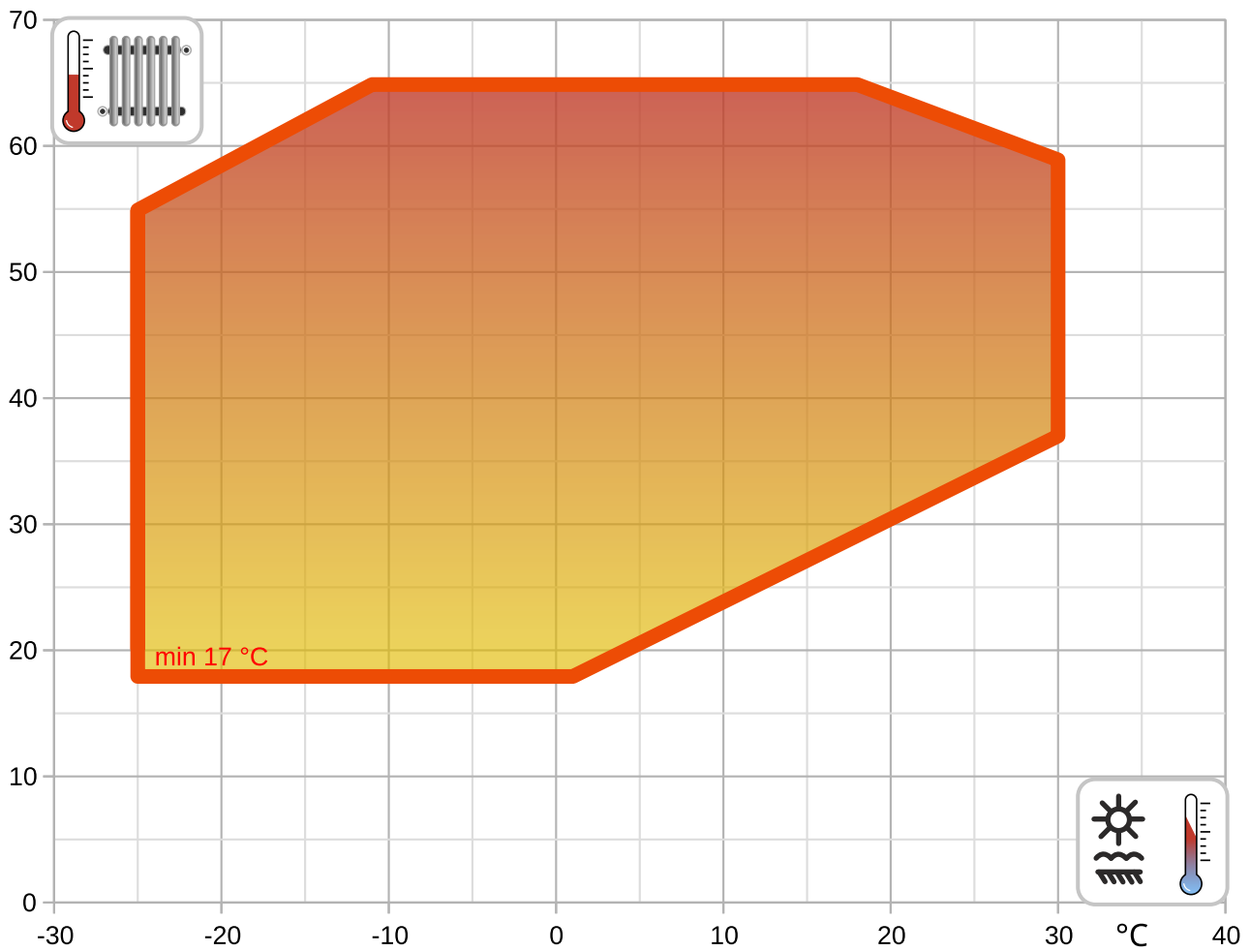

°C

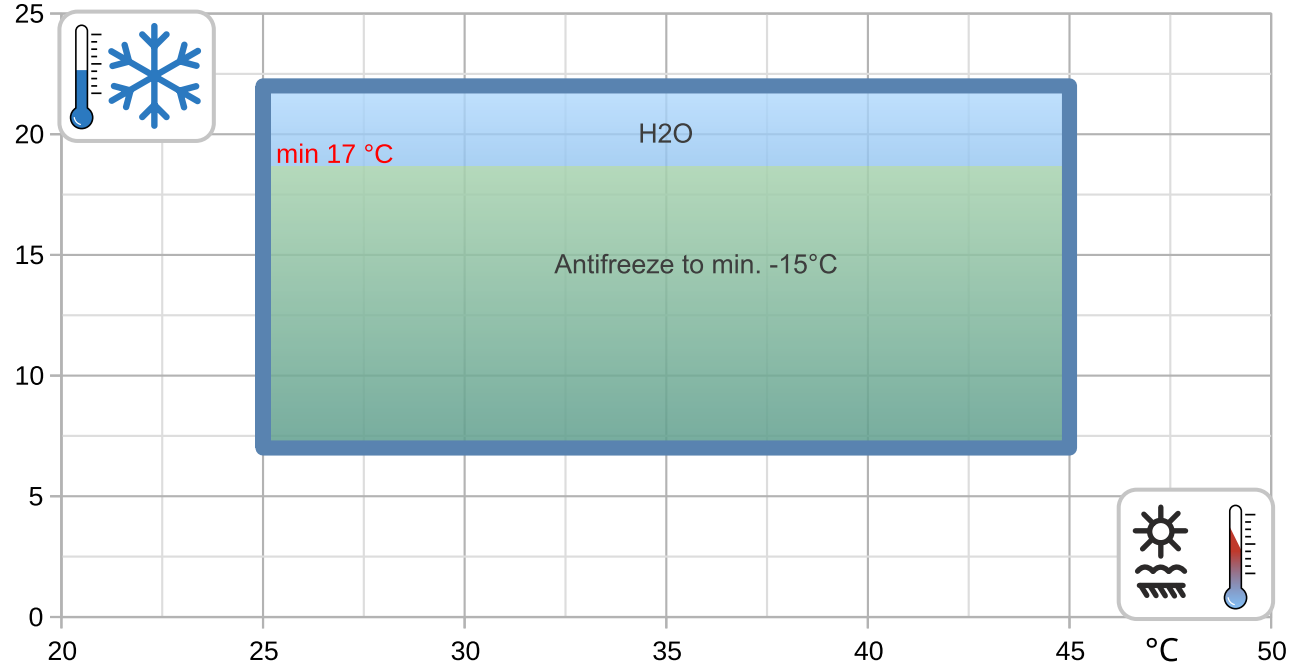

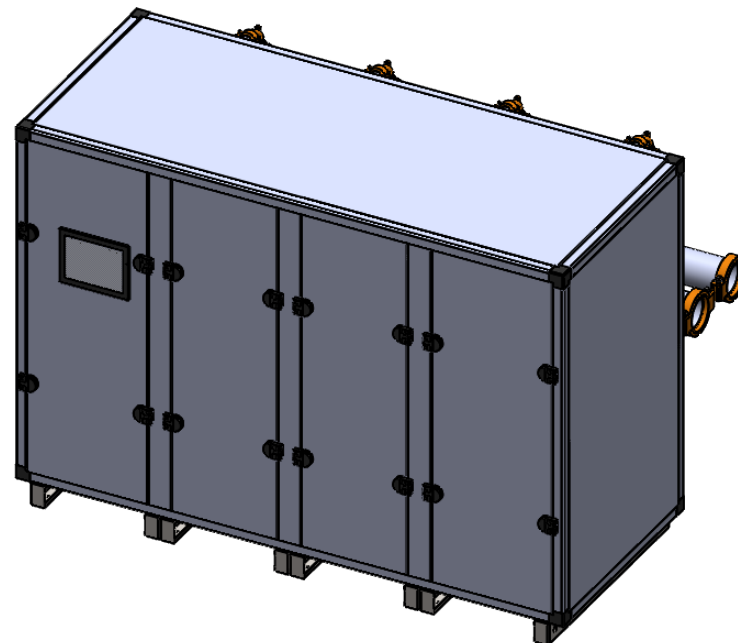
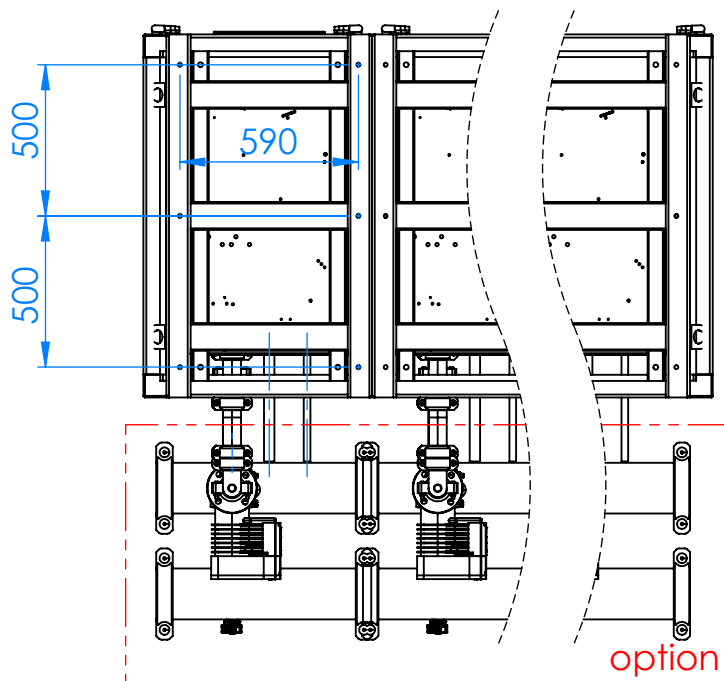
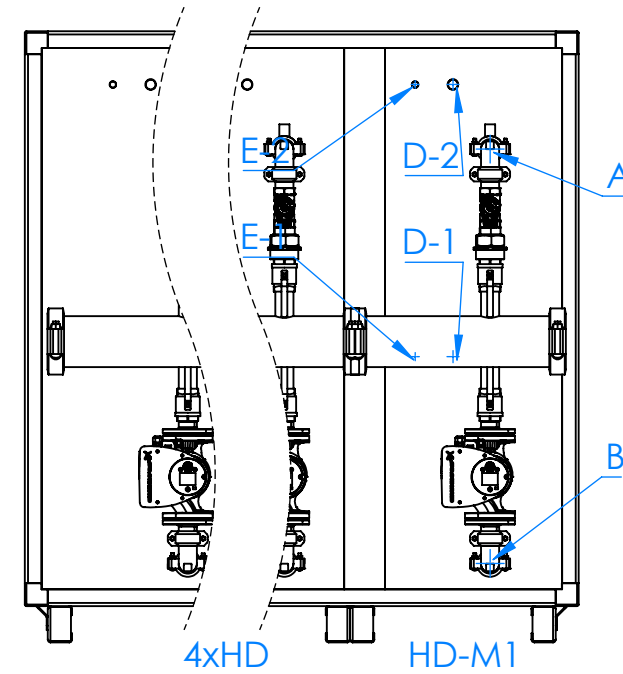
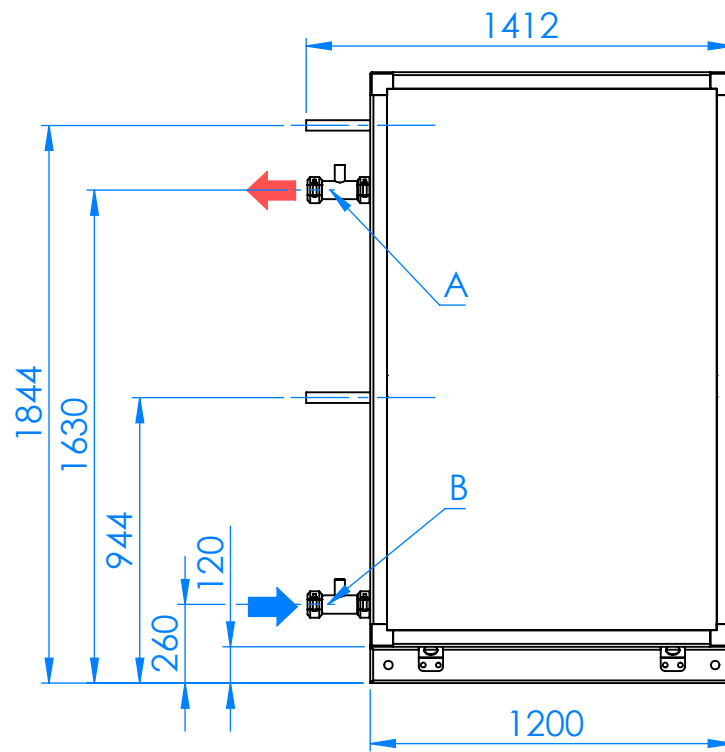
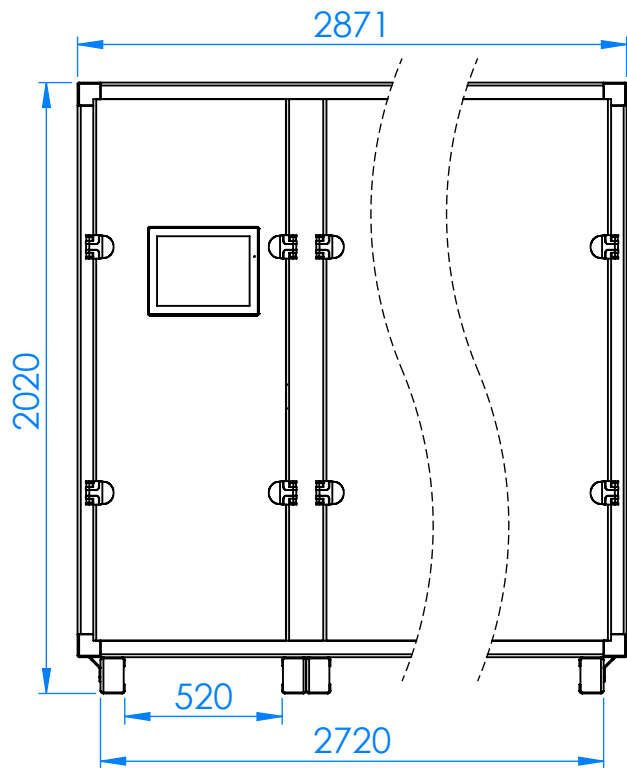

D (1,2,x) - SPLIT - FRIGO GAS
(Modul 1-2-x)

E (1,2,x) - SPLIT - FRIGO LIQUID
(Modul 1-2-x)

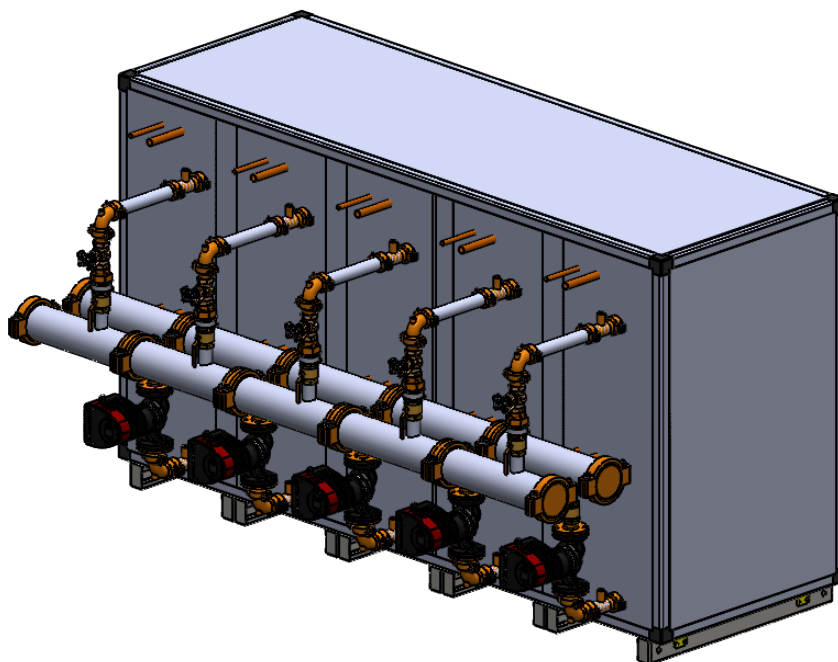
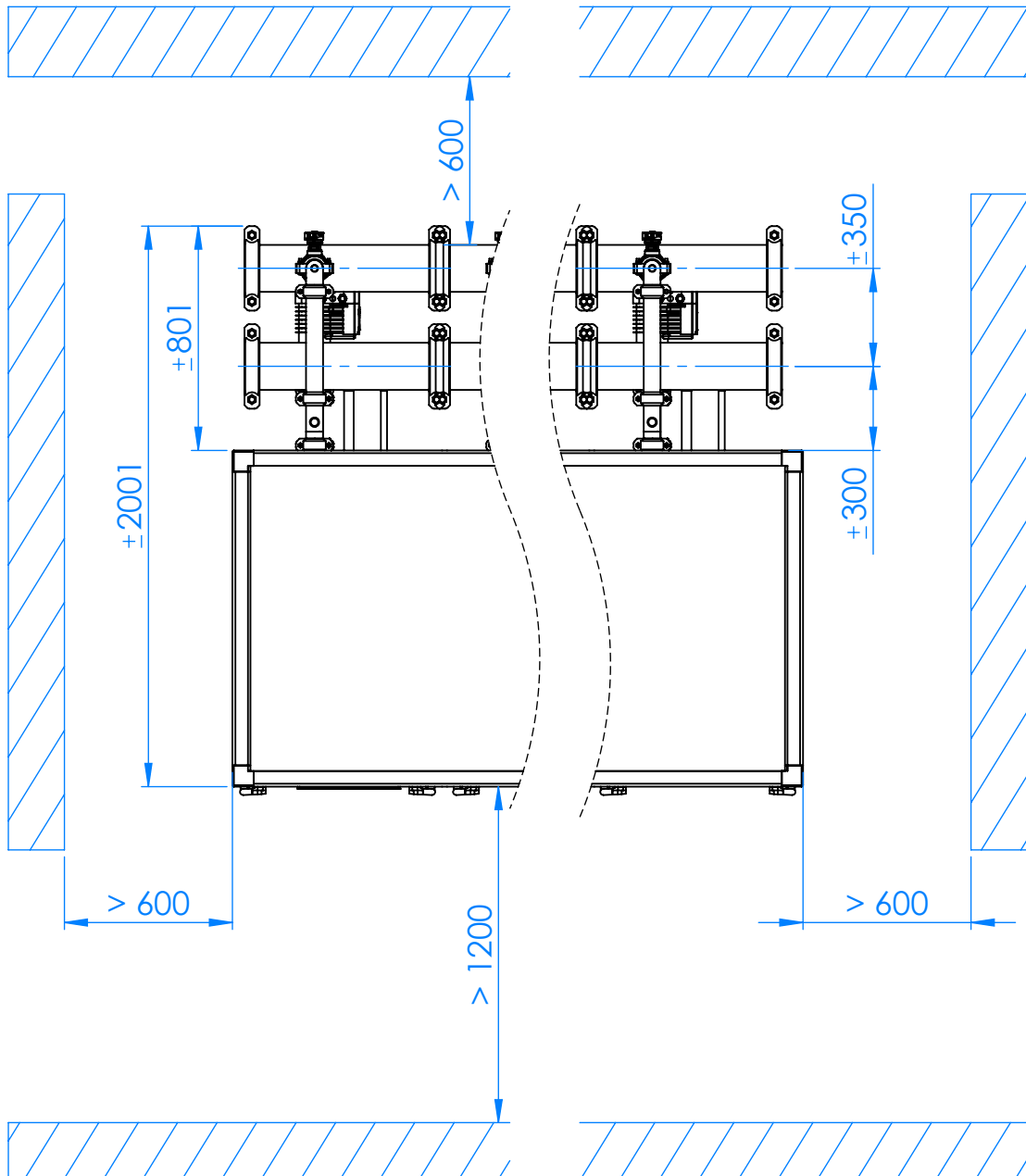

WAMAK AW 400 EVI HeavyDuty 2L4 - Variant Split jednotky: VOV900X2-FRAME

Potrebný počet jednotiek

4



Označenie krytovania: VOV900X2-FRAME			Výparník	
Kód výrobku	WAVV2X90		Typ	Cu-coil /Al-fin "
Základné rozmery	Výška [mm]	1400	Pripojovacia dimenzia	8 x (7/8" - 1.3/8") "
	Šírka [mm]	1500	Teplonosné médium	Vzduch
	Dĺžka [mm]	2300	Objemový prietok - Vzduch [m3/h]	15073 ~ 120580
Váha zariadenia [kg]	430		Vnútorná tlaková strata - Vzduch [kPa]	8 x 0.061
Farba krytovania	Nerez		Teplotný spád - Vzduch	7 K
IP trieda krytovania	IP44		Expanzný ventil	EEV
Ventilátor	800 mm			
Počet ventilátorov	2		Pozícia ventilátora	Vertikálna os
Typ motora ventilátora	EC		Typ ventilátora	Axial
Nominálny prúd ventilátora [A]	1.35		Napájanie ventilátora [V/Hz]	3~ 400/50
Minimálny príkon ventilátora [Watt]	81		Maximálny príkon ventilátora [Watt]	802

Zvuk - výkon Lw

79.5 dB(A)

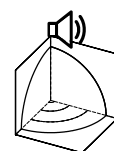
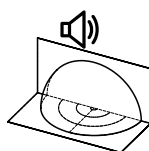
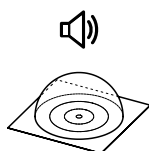

Odstup [m]	1	5	10	15	1	5	10	15	1	5	10	15
Zvuk - tlak Lp [dB(A)]	74.5	60.5	54.5	51	77.5	63.5	57.5	54	71.5	57.5	51.5	48

EC Fan 800mm

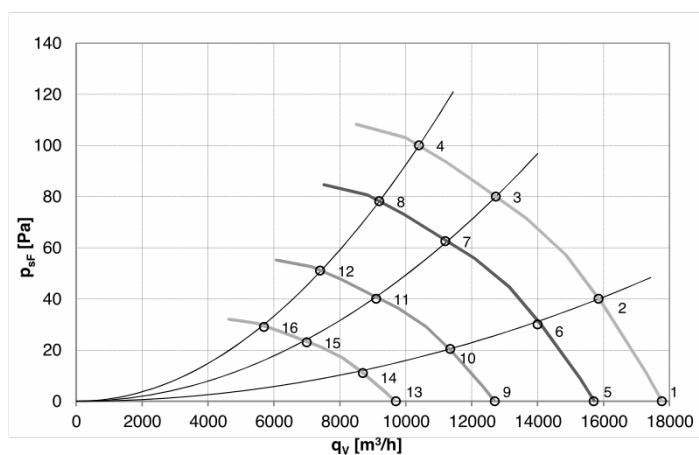

	U [V]	f [Hz]	n [RPM]	qv [m³/h]	PstF [Pa]	Pe [W]	I [A]	LwA out [dB (A)]	Ta max [°C]
1	400	50	735	17770	0	503	0,85	70	60
2	400	50	735	15850	40	612	1,02	66	60
3	400	50	735	12730	80	735	1,18	65	60
4	400	50	735	10400	100	802	1,36	68	60
5	400	50	650	15700	0	348	0,68	67	60
6	400	50	650	14000	30	421	0,80	63	60
7	400	50	650	11200	63	510	0,92	62	60
8	400	50	650	9200	78	554	0,93	65	60
9	400	50	525	12700	0	183	0,38	63	60
10	400	50	525	11350	20	225	0,35	59	60
11	400	50	525	9100	40	265	0,53	58	60
12	400	50	525	7400	51	292	0,57	61	60
13	400	50	400	9700	0	81	0,21	57	60
14	400	50	400	8700	11	97	0,24	53	60
15	400	50	400	7000	23	117	0,27	52	60
16	400	50	400	5700	29	128	0,28	55	60

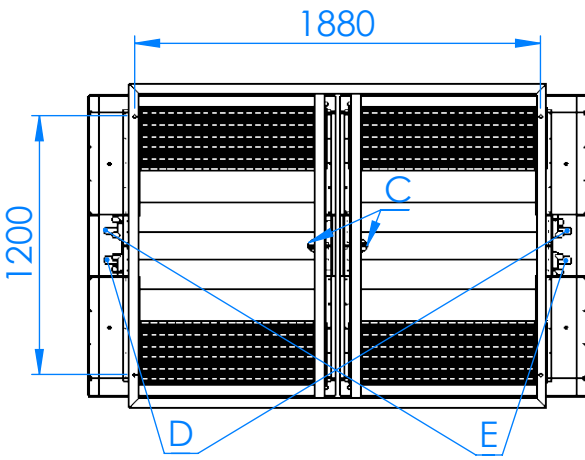
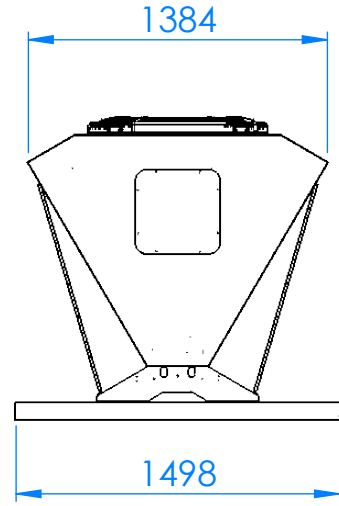
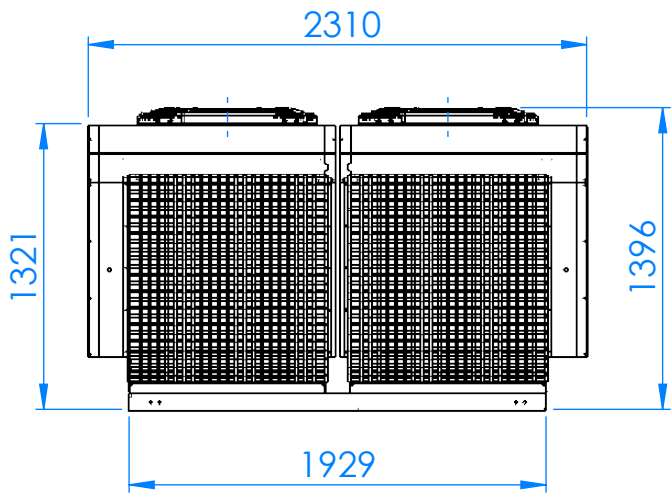

D - FRIGO GAS
E - FRIGO LIQUID
C - CONDENS

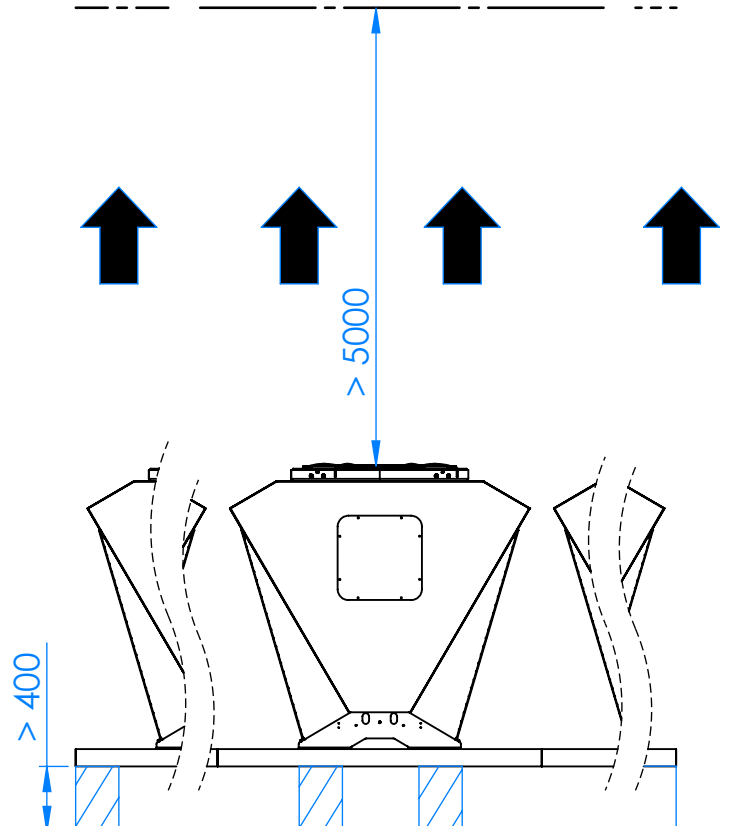
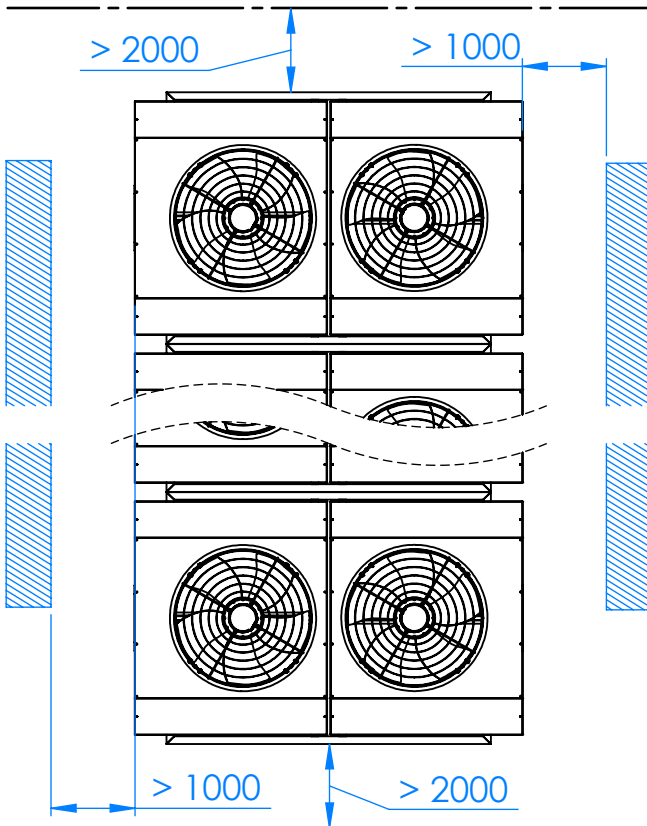
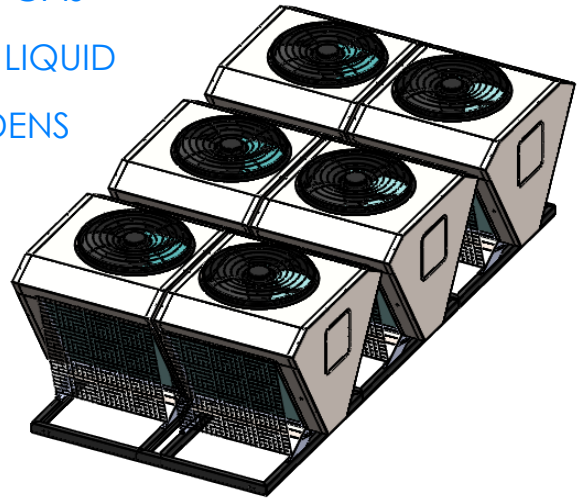

WAMAK AW 400 EVI HeavyDuty 2L4 - Variant Split jednotky: VOII-1200-2LOW

Potrebný počet jednotiek

8

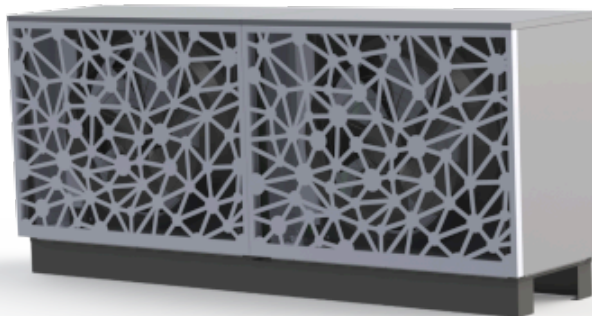

Označenie krytovania: VOII-1200-2LOW			Výparník	
Kód výrobku	WAVII12L		Typ	Cu-coil /Al-fin "
Základné rozmery	Výška [mm]	1240	Pripojovacia dimenzia	8 x (7/8" - 1.3/8") "
	Šírka [mm]	2850	Teplonosné médium	Vzduch
	Dĺžka [mm]	710	Objemový prietok - Vzduch [m3/h]	15073 ~ 120580
Váha zariadenia [kg]	300		Vnútorná tlaková strata - Vzduch [kPa]	8 x 0.061
Farba krytovania	Sivá		Teplotný spád - Vzduch	7 K
IP trieda krytovania	IP44		Expanzný ventil	EEV
Ventilátor	800 mm			
Počet ventilátorov	2		Pozícia ventilátora	Horizontálna os
Typ motora ventilátora	EC		Typ ventilátora	Axial
Nominálny prúd ventilátora [A]	1.35		Napájanie ventilátora [V/Hz]	3~ 400/50
Minimálny príkon ventilátora [Watt]	81		Maximálny príkon ventilátora [Watt]	802

Zvuk - výkon Lw

76.1 dB(A)

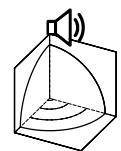
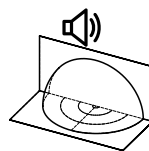
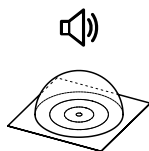

Odstup [m]	1	5	10	15	1	5	10	15	1	5	10	15
Zvuk - tlak Lp [dB(A)]	71.1	57.1	51.1	47.6	74.1	60.1	54.1	50.6	68.1	54.1	48.1	44.6

EC Fan 800mm

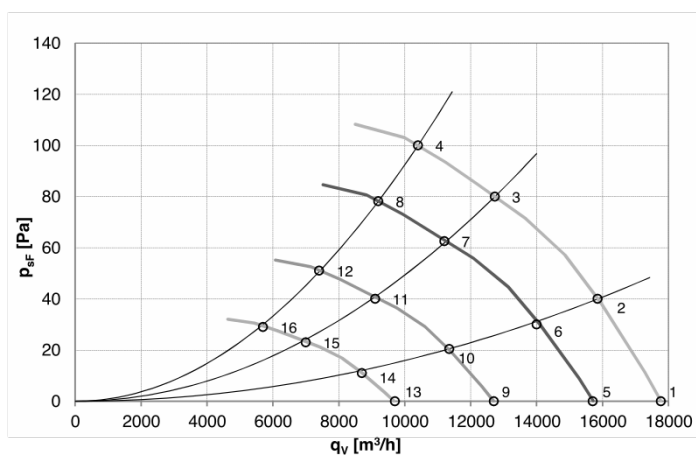

	U	f	n	qv	P _{sF}	P _e	I	L _{WA out}	T _{a max}
	[V]	[Hz]	[RPM]	[m³/h]	[Pa]	[W]	[A]	[dB (A)]	[°C]
1	400	50	735	17770	0	503	0,85	70	60
2	400	50	735	15850	40	612	1,02	66	60
3	400	50	735	12730	80	735	1,18	65	60
4	400	50	735	10400	100	802	1,36	68	60
5	400	50	650	15700	0	348	0,68	67	60
6	400	50	650	14000	30	421	0,80	63	60
7	400	50	650	11200	63	510	0,92	62	60
8	400	50	650	9200	78	554	0,93	65	60
9	400	50	525	12700	0	183	0,38	63	60
10	400	50	525	11350	20	225	0,35	59	60
11	400	50	525	9100	40	265	0,53	58	60
12	400	50	525	7400	51	292	0,57	61	60
13	400	50	400	9700	0	81	0,21	57	60
14	400	50	400	8700	11	97	0,24	53	60
15	400	50	400	7000	23	117	0,27	52	60
16	400	50	400	5700	29	128	0,28	55	60

WAMAK AW 400 EVI HeavyDuty 2L4

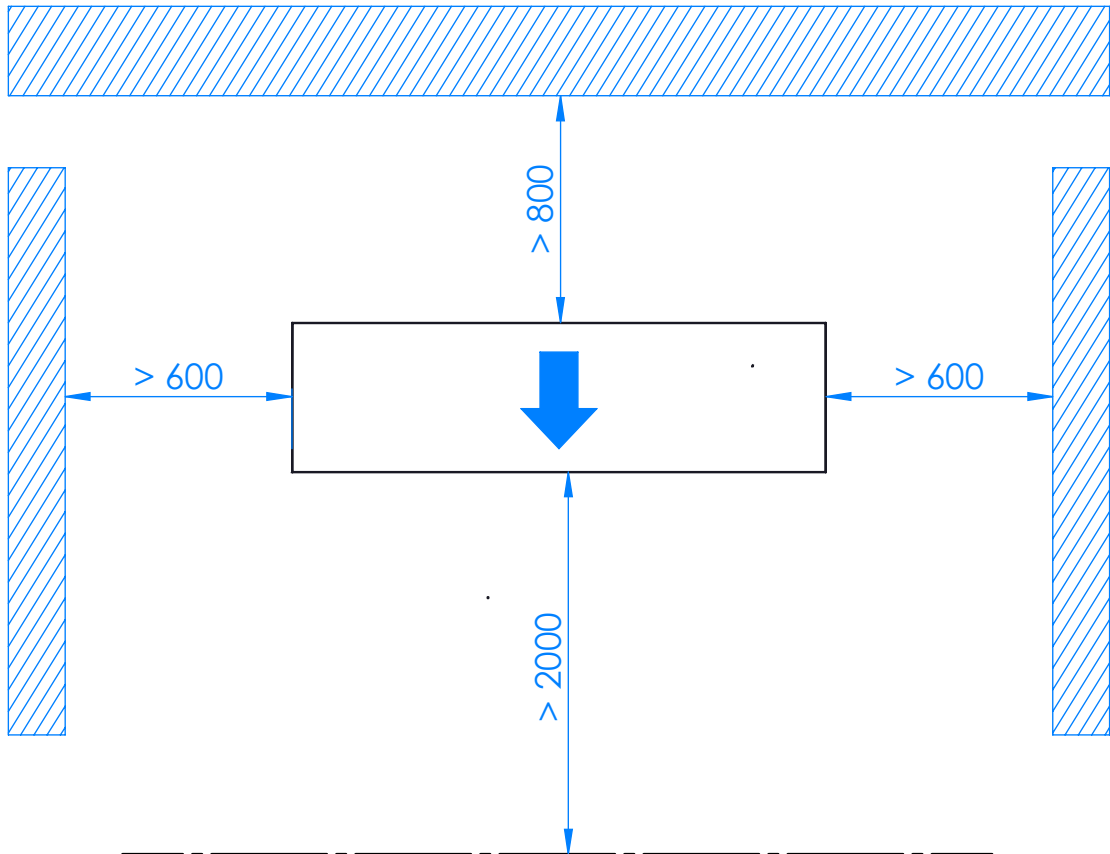
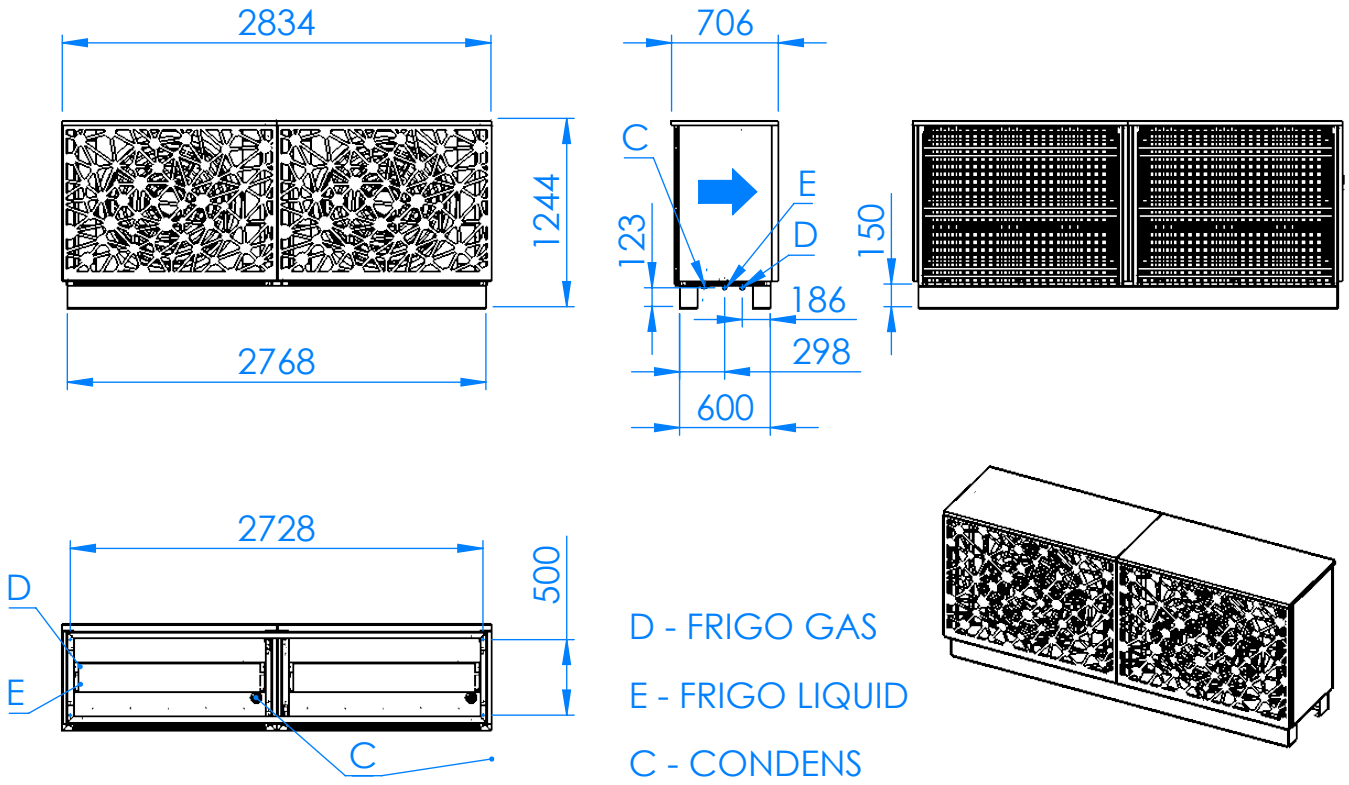

WAMAK AW 400 EVI HeavyDuty 2L4 - Variant Split jednotky: VOII-1200-2HIGH

Potrebný počet jednotiek

8

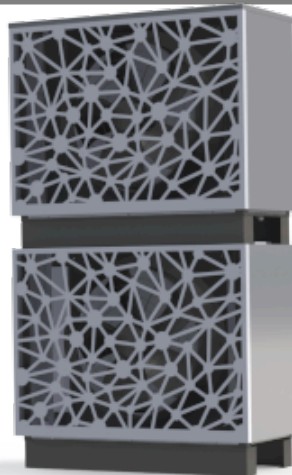

Označenie krytovania: VOII-1200-2HIGH			Výparník	
Kód výrobku	WAVII12H		Typ	Cu-coil /Al-fin "
Základné rozmery	Výška [mm]	2450	Pripojovacia dimenzia	8 x (7/8" - 1.3/8") "
	Šírka [mm]	1420	Teplonosné médium	Vzduch
	Dĺžka [mm]	710	Objemový prietok - Vzduch [m3/h]	15073 ~ 120580
Váha zariadenia [kg]	300		Vnútorná tlaková strata - Vzduch [kPa]	8 x 0.061
Farba krytovania	Sivá		Teplotný spád - Vzduch	7 K
IP trieda krytovania	IP44		Expanzný ventil	EEV
Ventilátor	800 mm			
Počet ventilátorov	2		Pozícia ventilátora	Horizontálna os
Typ motora ventilátora	EC		Typ ventilátora	Axial
Nominálny prúd ventilátora [A]	1.35		Napájanie ventilátora [V/Hz]	3~ 400/50
Minimálny príkon ventilátora [Watt]	81		Maximálny príkon ventilátora [Watt]	802

Zvuk - výkon Lw

76.1 dB(A)

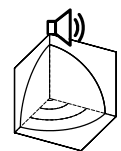
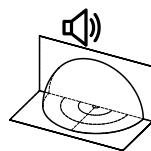
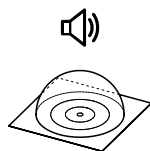

Odstup [m]	1	5	10	15	1	5	10	15	1	5	10	15
Zvuk - tlak Lp [dB(A)]	71.1	57.1	51.1	47.6	74.1	60.1	54.1	50.6	68.1	54.1	48.1	44.6

EC Fan 800mm

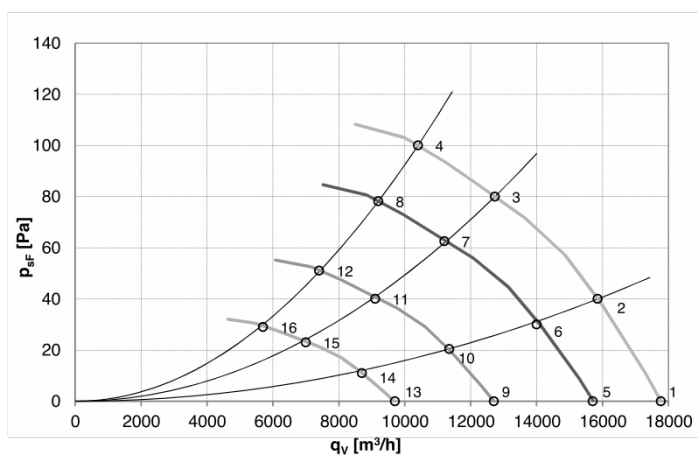

	U	f	n	q _v	P _{sF}	P _e	I	L _{WA out}	T _{a max}
	[V]	[Hz]	[RPM]	[m³/h]	[Pa]	[W]	[A]	[dB (A)]	[°C]
1	400	50	735	17770	0	503	0,85	70	60
2	400	50	735	15850	40	612	1,02	66	60
3	400	50	735	12730	80	735	1,18	65	60
4	400	50	735	10400	100	802	1,36	68	60
5	400	50	650	15700	0	348	0,68	67	60
6	400	50	650	14000	30	421	0,80	63	60
7	400	50	650	11200	63	510	0,92	62	60
8	400	50	650	9200	78	554	0,93	65	60
9	400	50	525	12700	0	183	0,38	63	60
10	400	50	525	11350	20	225	0,35	59	60
11	400	50	525	9100	40	265	0,53	58	60
12	400	50	525	7400	51	292	0,57	61	60
13	400	50	400	9700	0	81	0,21	57	60
14	400	50	400	8700	11	97	0,24	53	60
15	400	50	400	7000	23	117	0,27	52	60
16	400	50	400	5700	29	128	0,28	55	60

WAMAK AW 400 EVI HeavyDuty 2L4

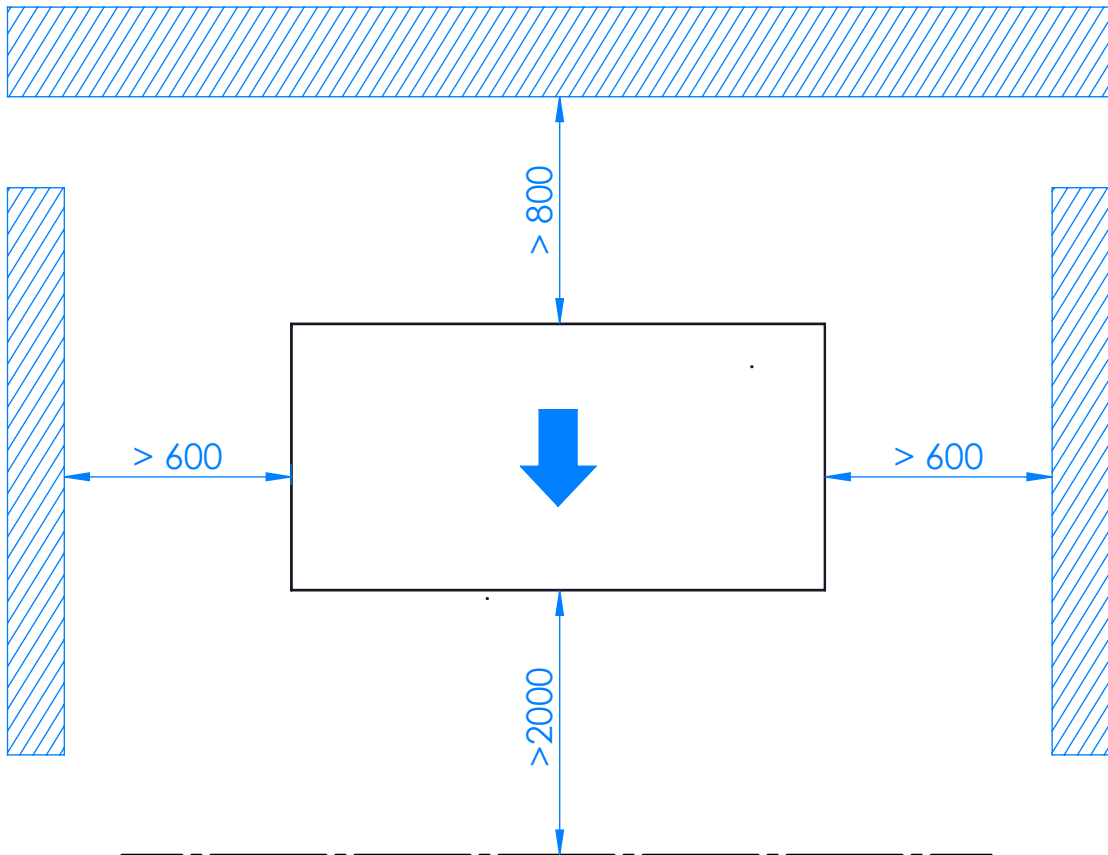
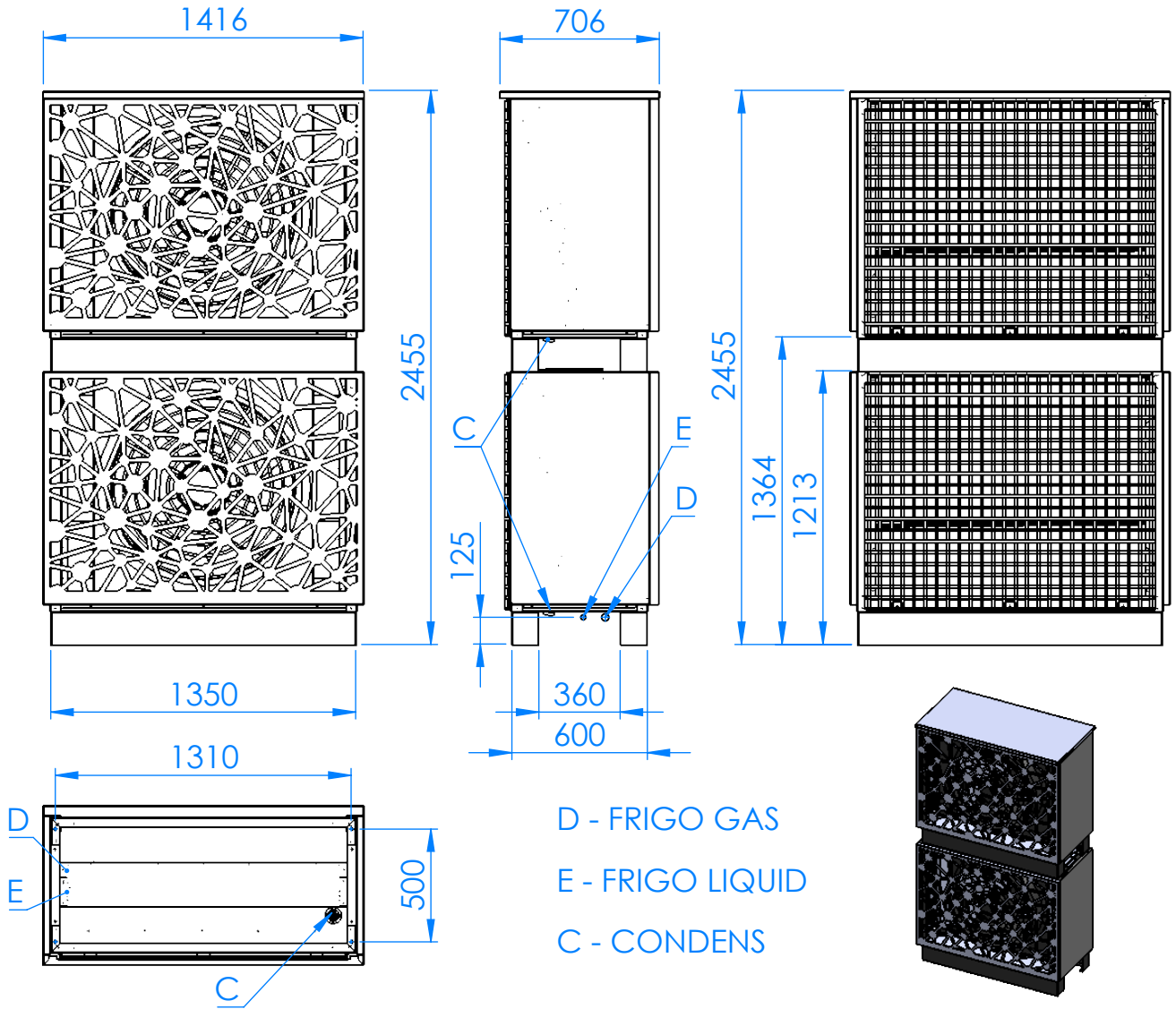

WAMAK AW 400 EVI HeavyDuty 2L4 - Variant Split jednotky: VOII-1200-2LOW-DUCT

Potrebný počet jednotiek

8

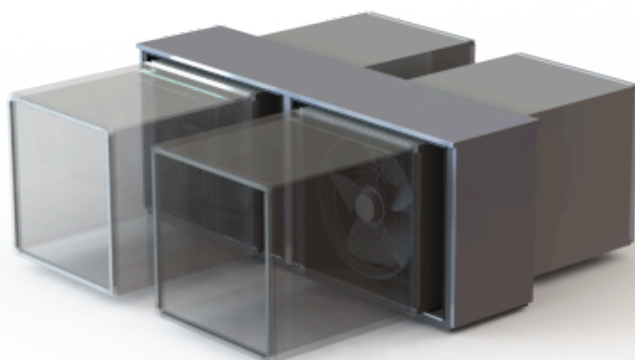

Označenie krytovania: VOII-1200-2LOW-DUCT			Výparník	
Kód výrobku	WAVID12L		Typ	Cu-coil /Al-fin "
Základné rozmery	Výška [mm]	1240	Pripojovacia dimenzia	8 x (7/8" - 1.3/8") "
	Šírka [mm]	2850	Teplonosné médium	Vzduch
	Dĺžka [mm]	710	Objemový prietok - Vzduch [m3/h]	15073 ~ 120580
Váha zariadenia [kg]	300		Vnútorná tlaková strata - Vzduch [kPa]	8 x 0.061
Farba krytovania	Sivá		Teplotný spád - Vzduch	7 K
IP trieda krytovania	IP44		Expanzný ventil	EEV
Ventilátor	800 mm			
Počet ventilátorov	2		Pozícia ventilátora	Horizontálna os
Typ motora ventilátora	EC		Typ ventilátora	Axial
Nominálny prúd ventilátora [A]	1.35		Napájanie ventilátora [V/Hz]	3~ 400/50
Minimálny príkon ventilátora [Watt]	81		Maximálny príkon ventilátora [Watt]	802

Zvuk - výkon Lw

76.1 dB(A)

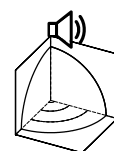
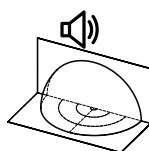
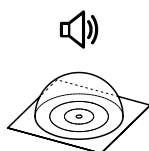

Odstup [m]	1	5	10	15	1	5	10	15	1	5	10	15
Zvuk - tlak Lp [dB(A)]	71.1	57.1	51.1	47.6	74.1	60.1	54.1	50.6	68.1	54.1	48.1	44.6

EC Fan 800mm

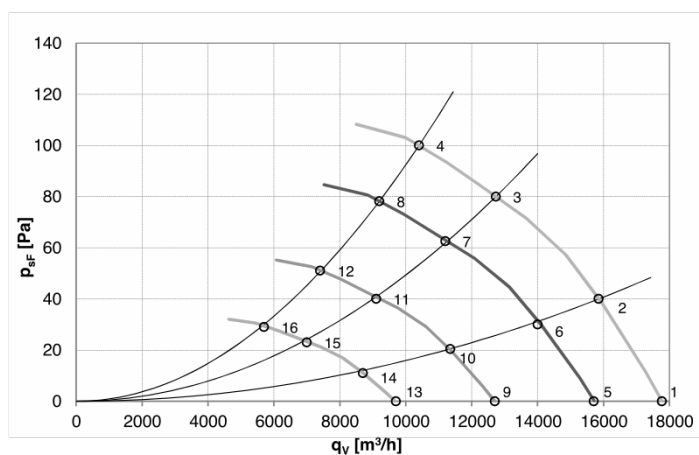

	U [V]	f [Hz]	n [RPM]	qv [m³/h]	PstF [Pa]	Pe [W]	I [A]	LwA out [dB (A)]	Ta max [°C]
1	400	50	735	17770	0	503	0,85	70	60
2	400	50	735	15850	40	612	1,02	66	60
3	400	50	735	12730	80	735	1,18	65	60
4	400	50	735	10400	100	802	1,36	68	60
5	400	50	650	15700	0	348	0,68	67	60
6	400	50	650	14000	30	421	0,80	63	60
7	400	50	650	11200	63	510	0,92	62	60
8	400	50	650	9200	78	554	0,93	65	60
9	400	50	525	12700	0	183	0,38	63	60
10	400	50	525	11350	20	225	0,35	59	60
11	400	50	525	9100	40	265	0,53	58	60
12	400	50	525	7400	51	292	0,57	61	60
13	400	50	400	9700	0	81	0,21	57	60
14	400	50	400	8700	11	97	0,24	53	60
15	400	50	400	7000	23	117	0,27	52	60
16	400	50	400	5700	29	128	0,28	55	60

WAMAK AW 400 EVI HeavyDuty 2L4 - Variant Split jednotky: VOII-1200-2HIGH-DUCT

Potrebný počet jednotiek

8

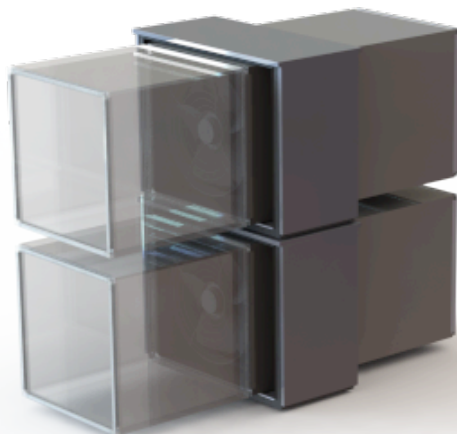

Označenie krytovania: VOII-1200-2HIGH-DUCT			Výparník	
Kód výrobku	WAVID12H		Typ	Cu-coil /Al-fin "
Základné rozmery	Výška [mm]	2450	Pripojovacia dimenzia	8 x (7/8" - 1.3/8") "
	Šírka [mm]	1420	Teplonosné médium	Vzduch
	Dĺžka [mm]	710	Objemový prietok - Vzduch [m3/h]	15073 ~ 120580
Váha zariadenia [kg]	300		Vnútorná tlaková strata - Vzduch [kPa]	8 x 0.061
Farba krytovania	Sivá		Teplotný spád - Vzduch	7 K
IP trieda krytovania	IP44		Expanzný ventil	EEV
Ventilátor	800 mm			
Počet ventilátorov	2		Pozícia ventilátora	Horizontálna os
Typ motora ventilátora	EC		Typ ventilátora	Axial
Nominálny prúd ventilátora [A]	1.35		Napájanie ventilátora [V/Hz]	3~ 400/50
Minimálny príkon ventilátora [Watt]	81		Maximálny príkon ventilátora [Watt]	802

Zvuk - výkon Lw

76.1 dB(A)

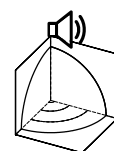
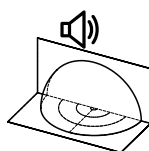
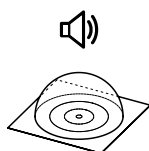

Odstup [m]

Zvuk - tlak Lp [dB(A)]

1	5	10	15	1	5	10	15	1	5	10	15
71.1	57.1	51.1	47.6	74.1	60.1	54.1	50.6	68.1	54.1	48.1	44.6

EC Fan 800mm

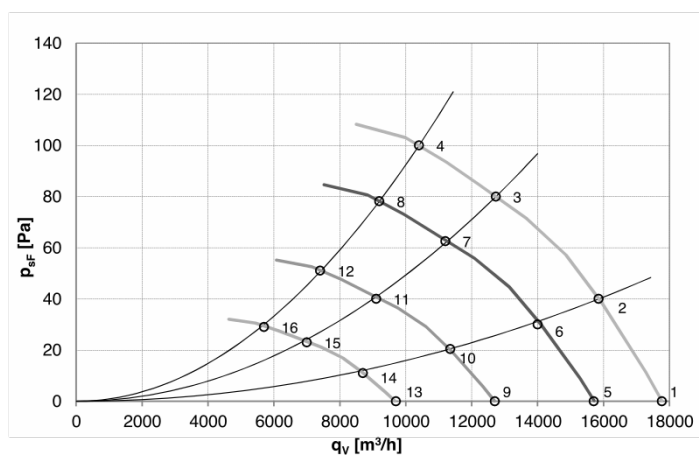

	U	f	n	qv	P _{sF}	P _e	I	L _{WA out}	T _{a max}
	[V]	[Hz]	[RPM]	[m³/h]	[Pa]	[W]	[A]	[dB (A)]	[°C]
1	400	50	735	17770	0	503	0,85	70	60
2	400	50	735	15850	40	612	1,02	66	60
3	400	50	735	12730	80	735	1,18	65	60
4	400	50	735	10400	100	802	1,36	68	60
5	400	50	650	15700	0	348	0,68	67	60
6	400	50	650	14000	30	421	0,80	63	60
7	400	50	650	11200	63	510	0,92	62	60
8	400	50	650	9200	78	554	0,93	65	60
9	400	50	525	12700	0	183	0,38	63	60
10	400	50	525	11350	20	225	0,35	59	60
11	400	50	525	9100	40	265	0,53	58	60
12	400	50	525	7400	51	292	0,57	61	60
13	400	50	400	9700	0	81	0,21	57	60
14	400	50	400	8700	11	97	0,24	53	60
15	400	50	400	7000	23	117	0,27	52	60
16	400	50	400	5700	29	128	0,28	55	60

WAMAK AW 400 EVI HeavyDuty 2L4

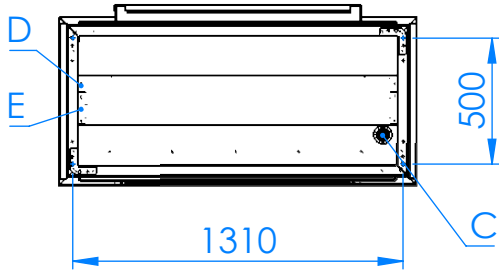
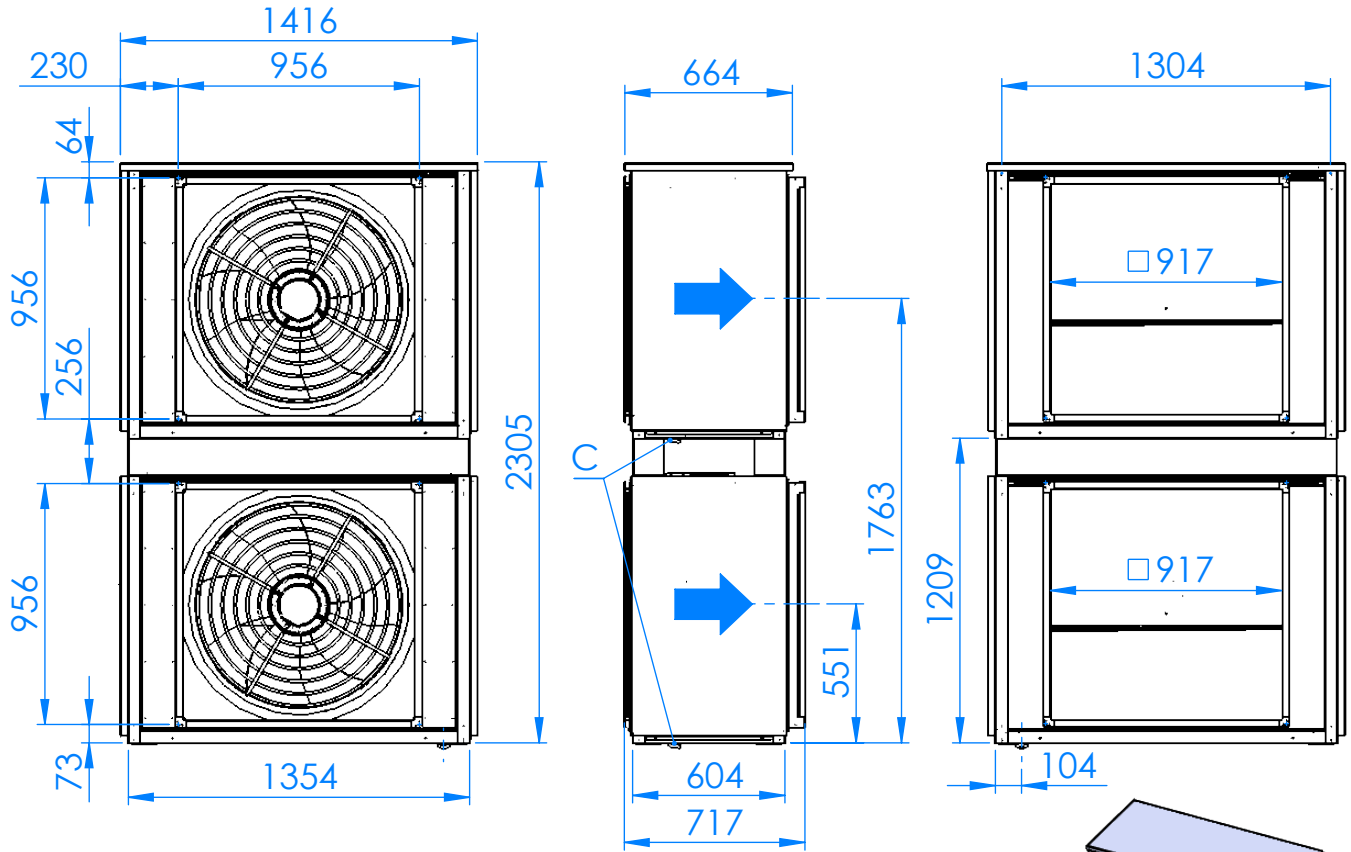

D - FRIGO GAS
 E - FRIGO LIQUID
 C - CONDENS

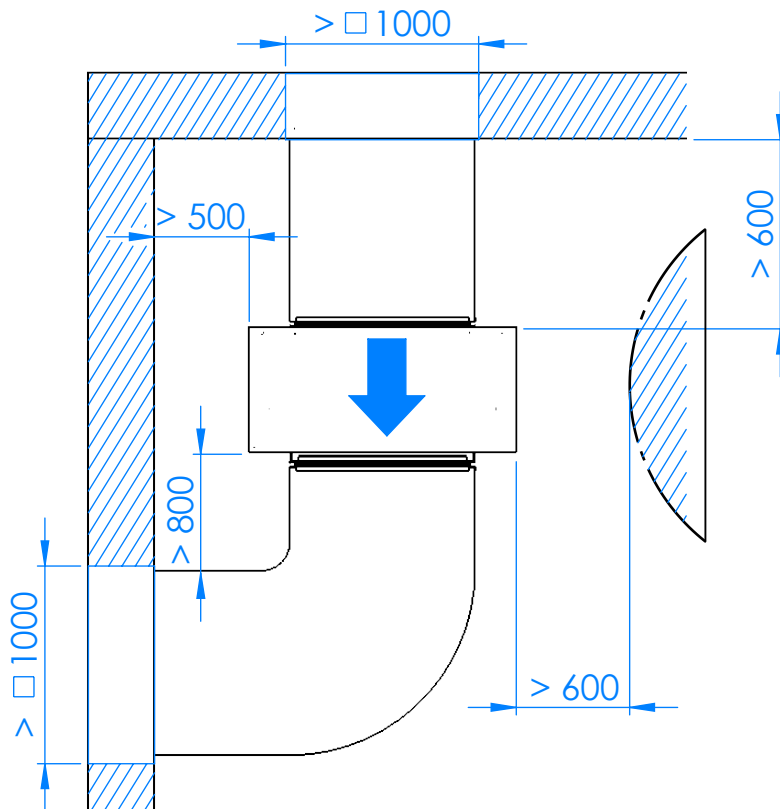
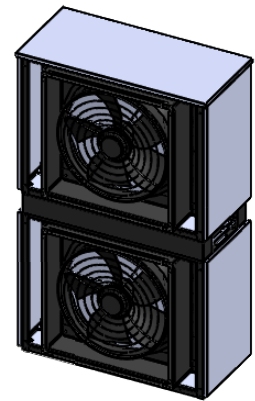

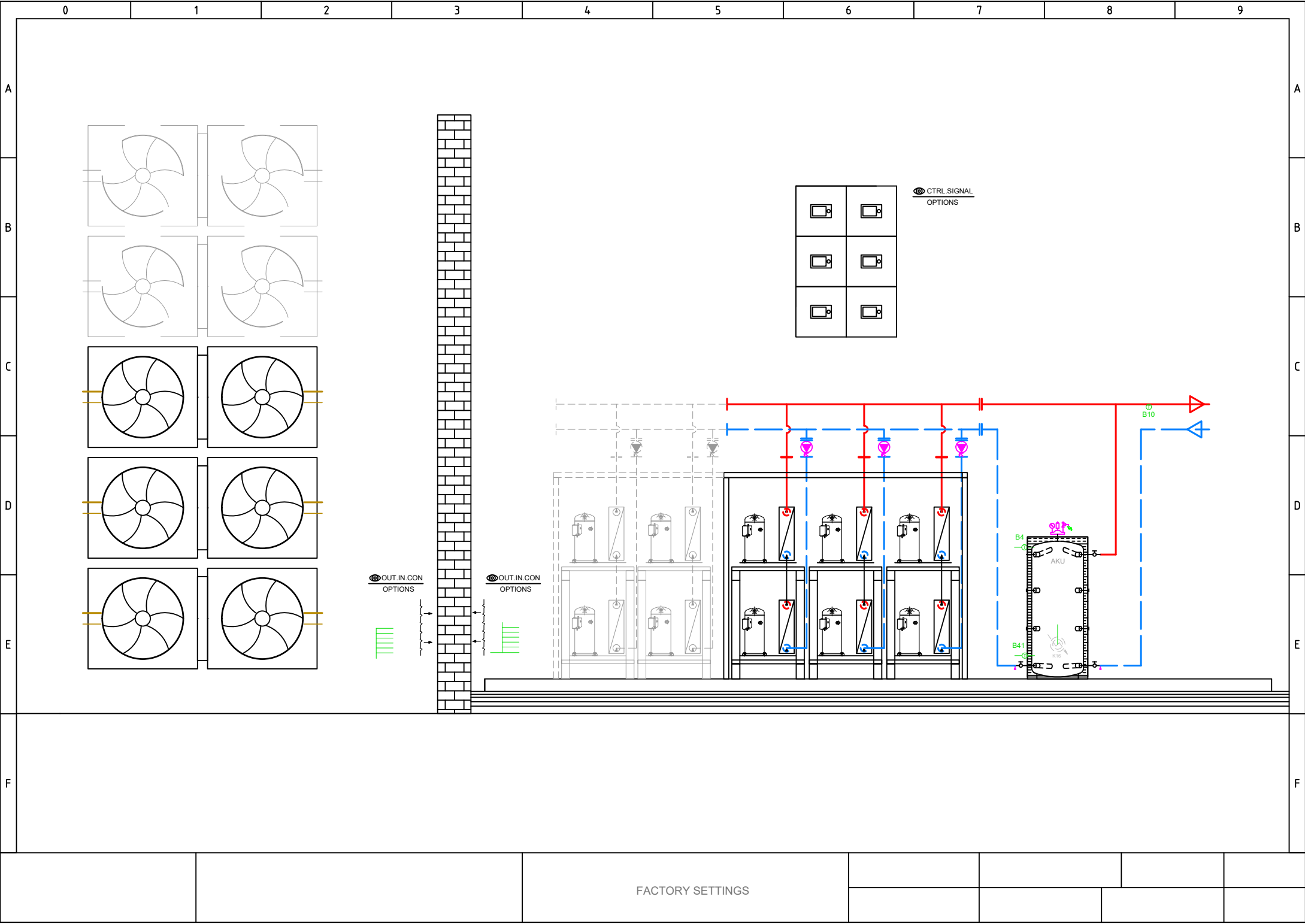

CTRL.SIGNAL
OPTIONS

OUT.IN.CON
OPTIONS

OUT.IN.CON
OPTIONS

B4
AKU
B10
B41
K18

FACTORY SETTINGS



Hlavné napájanie 230V / 50 Hz
 Uzemnenie
 Nulový vodič

- E10 Spínač vysokého tlaku E10
- E11 Preťaženie kompresora E11
- E14 Preťaženie zdroja E14
- E24 Spínač prietoku spotreby E24
- K82 Ventil EVI K82

K40 Ohrev oleja K40

- L Fáza 230V
- K1 Kompresor I. stupeň K1
- Y22 Reverzný ventil Y22

Q9 Čerpadlo kondenzátora Q9

X10	1	L
X10	1	PE
X10	1	N
X11	1	EX1
X11	1	EX2
X11	1	EX3
X11	1	EX4
X12	1	QX1
X12	1	N
X12	1	QX2
X12	1	QX2i
X12	1	N
X12	1	FX3
X15	1	QX3
X15	1	QX4
X15	1	QX4i
X15	1	N
X15	1	QX5
X15	1	N
X15	1	ZX6
X15	1	N
X86	1	GX1
X86	1	H3
X86	1	M
X86	1	H1
X86	1	G+
X86	1	M
X86	1	BSB

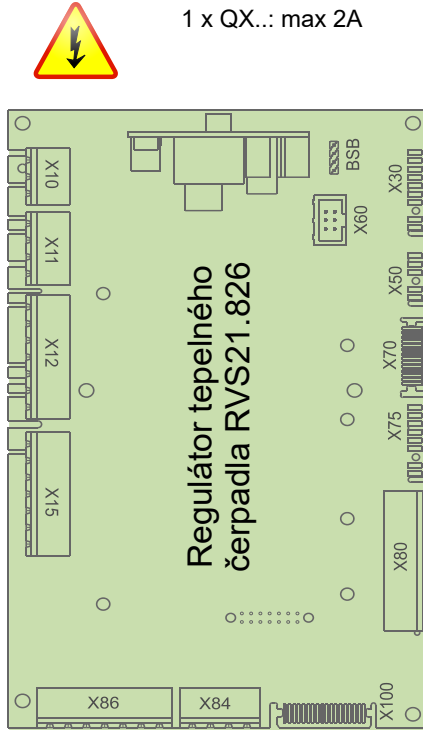

Total: max 6A
 1 x QX...: max 2A

BSB
X30
X60
X50
X70

- Pripojenie Servicetool (OCI700)
- Obslužná jednotka
- Modbus clip-in OCI351.01
- Rozširovací modul AVS75.xxx
- LPB clip-in

D1
D2
D3
UX3
M
DI6
DI7
M

- D1 Digitálny výstup 1 kúrenia
- D2 Digitálny výstup 2 chladenia
- D3 Digitálny výstup 3 TČ Zap./Vyp.

- DI6 Digitálny vstup 6 odmrazenie
- DI7 Digitálny vstup 7 Alarm

BX1
M
BX2
M
UX1
M
UX2
M

- B91 Snímač vstupu zdroja B91
- B84 Snímač výstupu zdroja B92/B84
- K19 Ventilátor K19
- 0..10V analógový signál
- Q9 Čerpadlo kondenzátora Q9
- PWM Signal

BX3
M
BX4
M

- B71 Snímač teploty spiatocky TČ B71
- B9 Snímač vonkajšej teploty B9

Hlavné napájanie 230V / 50 Hz
 Uzemnenie
 Nulový vodič

K10 Alarmový výstup K10

V81 EEV výparníka V81

X10	1	L
X10	1	PE
X10	1	N
X110	1	QX31
X110	1	QX32
X110	1	QX33
X110	1	N
X110	1	QX33
X110	1	ZX34
X110	1	N
X110	1	QX35
X110	1	QX35i
X115	1	N

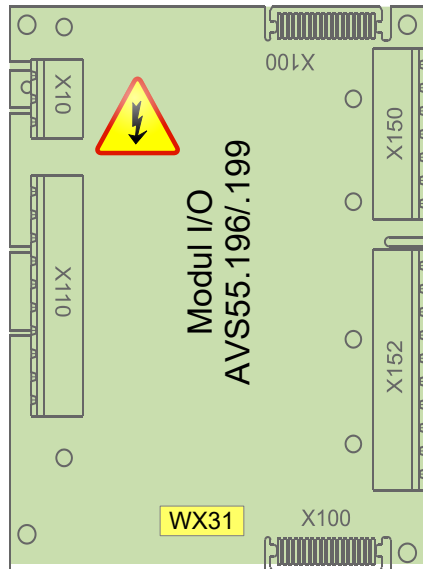

BSB
M
G+
H31
M
H32
GX1
H33
M
BX31
M
BX32
M
BX33
M
BX34
M

- 5V/12V aktívne snímače
- Meranie prietoku 10V
- Nízky tlak 0..10V
- 5V/12V aktívne snímače
- Vysoký tlak 0..10V
- B21 Snímač teploty výstupu TČ B21
- B81 Snímač horúcich plynov B81
- B85 Snímač plynov sania B85
- B83 Snímač chladiaceho média B83



- AVS75.390
- AVS75.391
- AVS75.370

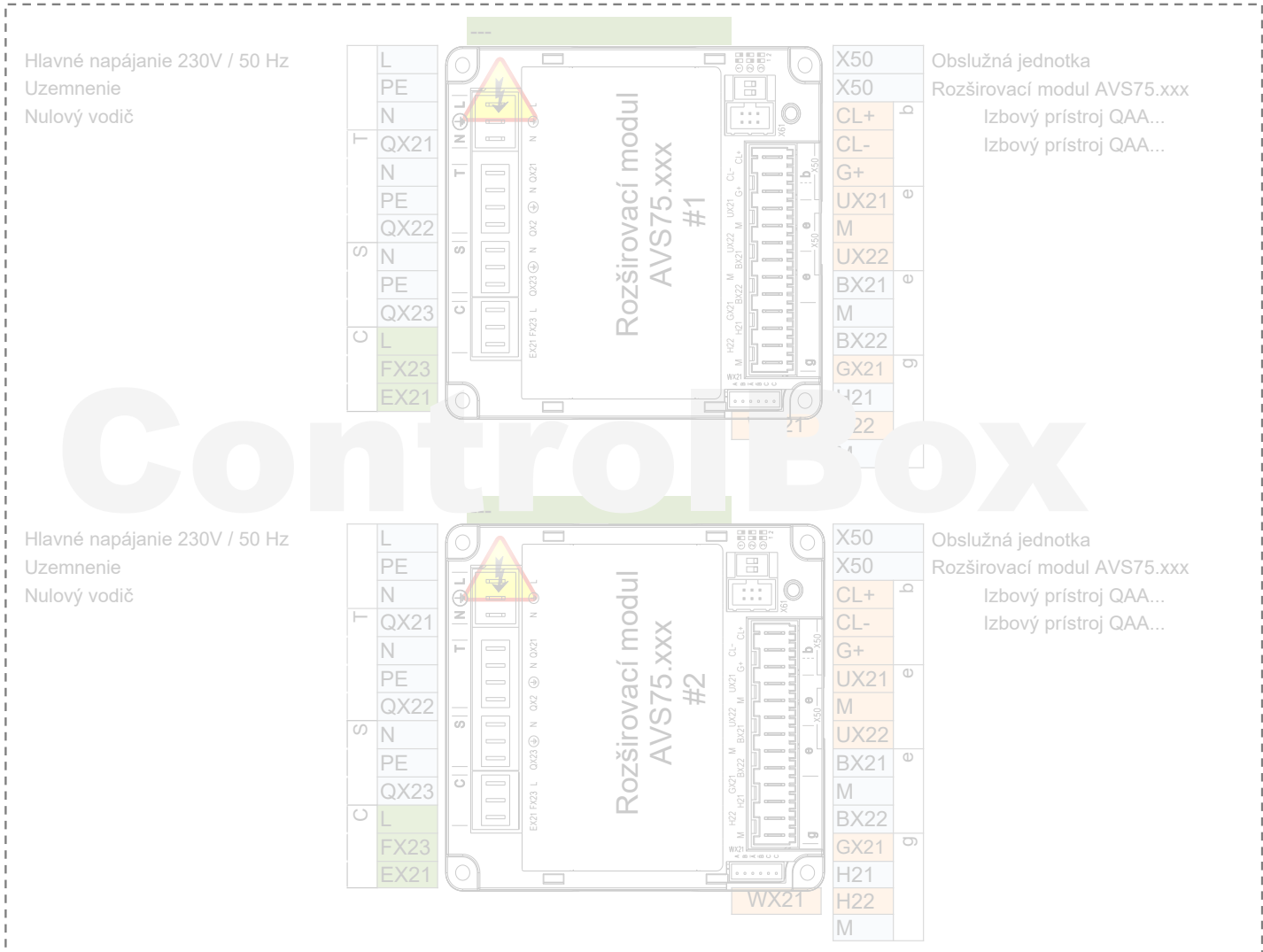

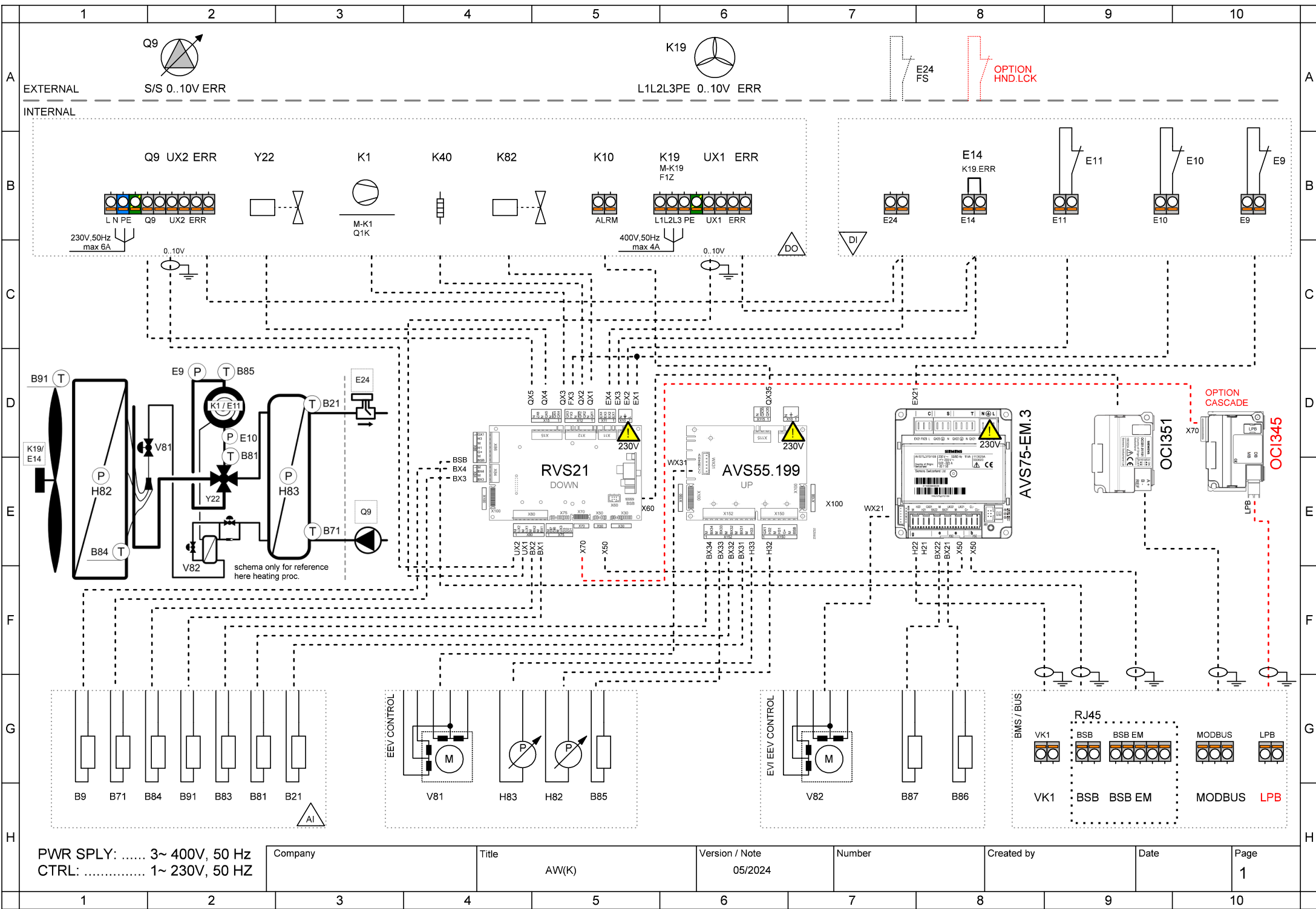

PWR SPLY: 3~ 400V, 50 Hz
CTRL: 1~ 230V, 50 HZ

Company	Title	Version / Note	Number	Created by	Date	Page
	AW(K)	05/2024				1

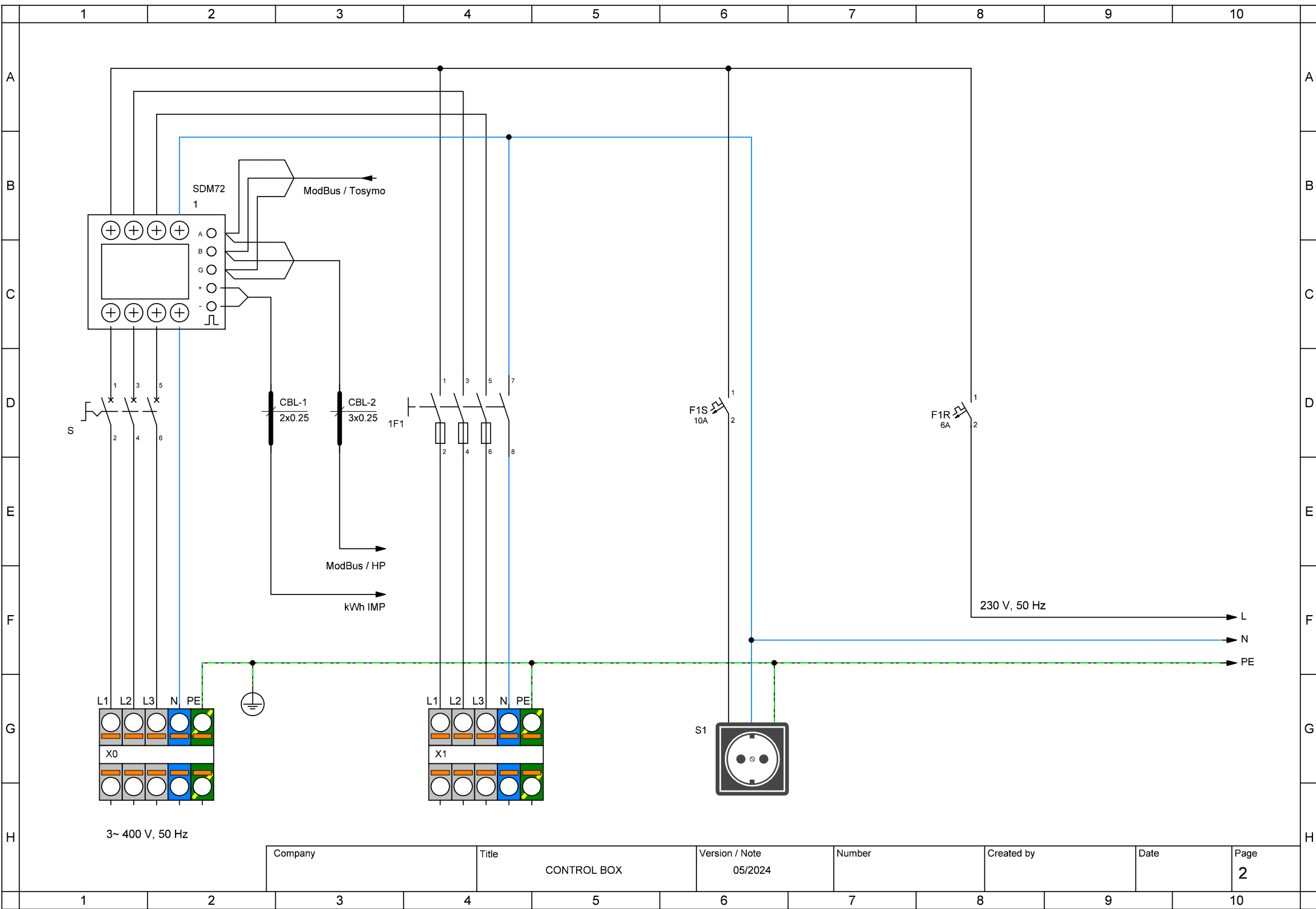

Company	Title	Version / Note	Number	Created by	Date	Page
	CONTROL BOX	05/2024				2

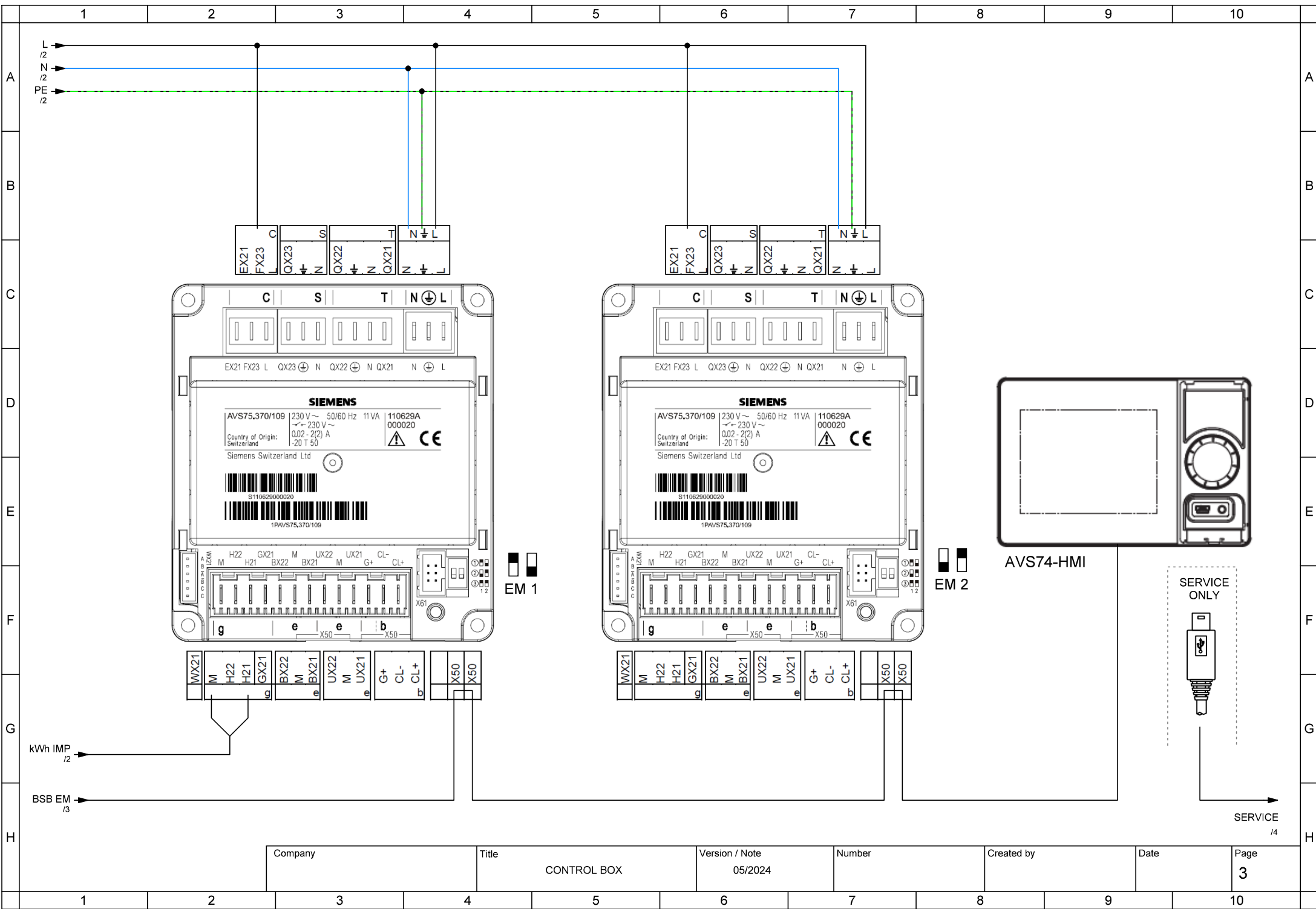

Company	Title	Version / Note	Number	Created by	Date	Page
	CONTROL BOX	05/2024				3

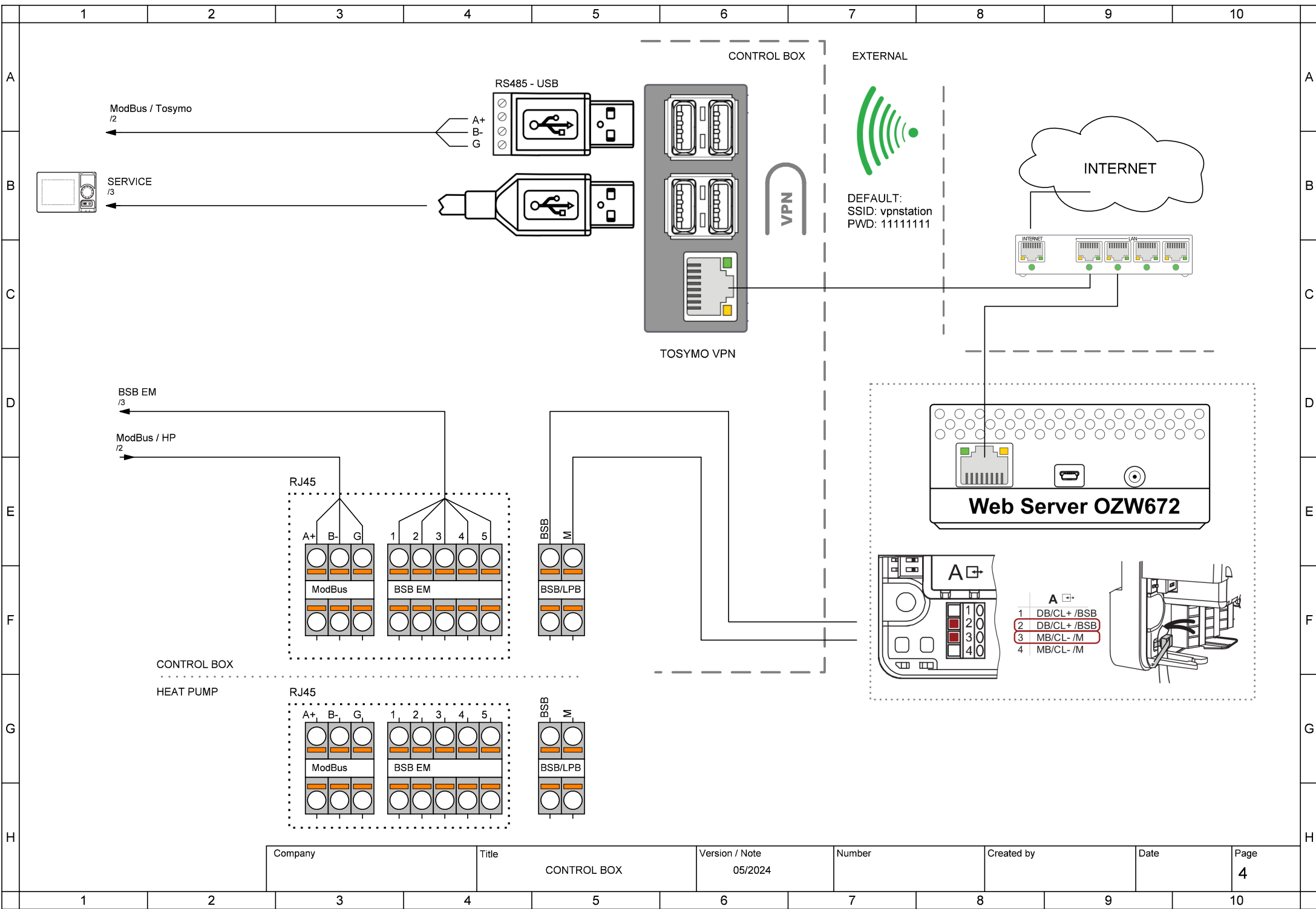

1 ControlBox

ControlBox s dvoma zabudovanými rozširujúcimi modulmi umožňuje početné možnosti ovládania aplikácie na strane spotrebiča za tepelným čerpadlom. Viac informácií nájdete v schéme ControlBoxu a v hárku s aplikačnými schémami.

2 Fixná žiadaná teplota výstupu - Zap / Vyp bezpotenciálny kontakt

2-vodičový tienený kábel 2 x 0,5 mm² - Nastavená hodnota = 45 °C (upraviteľné parametrom 1859)

Pripojovacia svorka - pozri schému zapojenia

3 Analógová regulácia žiadanej teploty výstupu 0..10V

2-vodičový tienený kábel 2 x 0,5 mm² - Nastavená hodnota: 0V = 16°C ~ 10V = 60°C (možnosť úpravy v nastavení parametrov)

Pripojovacia svorka - pozri schému zapojenia

4 ModBus RTU komunikačný príkaz

3 žilový tienený kábel min. 3 x 0,25 mm²

Pre tabuľku mapovania ModBus kontaktujte technickú podporu

5 MQTT IoT komunikačný protokol

Pre viac informácií kontaktujte technickú podporu