

Grundlegende Leistungsdaten - WAMAK AW 300 EVI HeavyDuty 2L3

Heizen - EN 14511		
Wärmeleistung [kW]	A7 / W35	294.5 (49.1 / 294.5)
	A2 / W35	250.2 (41.7 / 250.2)
	A-7 / W34	209.9 (35.0 / 209.9)
Leistungsaufnahme [kW]	A7 / W35	68.3 (10.7 / 68.3)
	A2 / W35	68.2 (10.7 / 68.2)
	A-7 / W34	66.3 (10.4 / 66.3)
Leistungszahl Heizen [COP]	A7 / W35	4.31
	A2 / W35	3.67
	A-7 / W34	3.17
Jahreszeitbedingte Raumheizungs-Energieeffizienz - SCOP EN 14825		
Klimazone Durchschnitt / Niedrigtemp. [35°C]	SCOP	4.23
	η [%]	169.4
	Label	A+++
	Qhe [kWh]	115769.8
	Pdesignh [kW]	238.0
	Tbivalent [°C]	-7
Kühlung		
Kühlleistung - [kW]	A35 / W23-18	290.6
	A25 / W23-18	305.4
	A35 / W12-7	218.3
	A25 / W12-7	218.3
Jahreszeitbedingte Raumkühlungs-Energieeffizienz - SEER EN 14825		
[W 23 / 18°C]	SEER	4.55
	Qce [kWh]	130980.0
	η_c [%]	181.9
Schall EN 12102		
Schalleistungspegel - Lw	dB(A)	72.5
Schalldruckpegel - Lp	1 m dB(A)	64.5
	5 m dB(A)	50.5
	10 m dB(A)	44.5
Mechanische und Betriebs-Informationen		
Verdichterbauart (3~ 400/50)	SCROLL / 6 /	Ein/Aus
Kältemittel	R410A (GWP - 2088)	6 x 9.6 kg
Einsatzgrenze Heizungswasser - (min / max) [°C]		25 / 65
Einsatzgrenze Wärmequelle - (min / max) [°C]		-22 / 40
Gewicht		1495 kg

Wichtigste technische Daten - WAMAK AW 300 EVI HeavyDuty 2L3

Gehäuse Bezeichnung		HD2L3		Daten von Wärmeabgabe	
Grundlegende Abmessungen	Hohe [mm]	2000		Einsatzgrenze Heizungswasser	MAX [°C] 65
	Breite [mm]	2150			MIN [°C] 25
	Länge [mm]	1200		genauer siehe Betriebsgrenzendiagramm	
Gewicht [kg]	1495		Kondensator	Anschlussdimension	6 x 2 "
Gehäuse Farbe	Grau			Bauart	BPHE
Gehäuse IP Klasse	IP20			Anzahl	6
Kältekreis				Material	AISI 316
Verdichter	Bauart	Scroll		Maximaler Überdruck - Kältemittel [bar]	50
	Leistungsstufen	6		Maximaler Überdruck - Wasser [bar]	6
	Ein/Aus			Prüfdruck [bar]	70
	Leistungsfaktor Cosφ	0.64		Wärmeträger	Wasser
	Wicklungswiderstand	0.76 Ohm		Volumenstrom @ dT 5K (nom) - Wasser [m3/h]	8.48 ~ 50.86
Kältemittel		R410A		Interne Druckdifferenz - Wasser [kPa]	6 x 20
	Menge	6 x 9.6 kg		Temperaturdifferenz @ 35°C (nom)	5 K
	GWP	2088		@ 55°C	8 K
	Sicherheitsklasse	A1		@ 65°C	10 K
Kältemittelöl	POE RL32-3MAF			Daten von Erneuerbarer Energiequelle	
	Ölmenge	6 x 3.38 L		Einsatzgrenze Wärmequelle	MIN [°C] -22
Maximaler Hochdruck - Kältemittel [bar]		50			MAX [°C] 40
	PED Klasse	2		genauer siehe Betriebsgrenzendiagramm	
EVI - Dampfeinspritzung mit Ekonomiser					
APS System mit Flüssigkeitsunterkühlung					
Reversibler Betrieb (Kühlung)					
Reversible Abtauung mit Heissgas					
Plattentauscherschutz HG-BYPASS					
Daten von Elektroanschluss					
Einspeisung [#~ V/Hz]		3~ 400/50			
Strom	Nominal [A]	141.18		Verdampfer	Anschlussdimension 6 x (7/8" - 1.3/8") "
	Maximal [A]	224.40			Bauart Cu-coil /Al-fin
	Start [A]	57.2			Anzahl 6
Sanftanlasser	-			Material	Cu/Al
Hauptsicherung	C240		Maximaler Überdruck - Kältemittel [bar]	29	
Steuerungssystem					
Hauptregler	SIEMENS	RVS 21	AVS 55.199	Wärmeträger	Luft
Erweiterungsmo dul	AVS75.3xx	AVS75.3xx	AVS75.372	Volumenstrom - Luft [m3/h]	15073 ~ 90440
Bus Clip-In		LPB OCI347	Modbus OCI353	Interne Druckdifferenz - Luft [kPa]	6 x 0.061
Online-Verbindung		Web server OZW672	ToSyMo	Temperaturdifferenz - Luft	7 K
EEV Regelung			SEC61	Mögliche Ausseneinheiten	3 x VOV900X2-FRAME
*** mit Zubehör					
Split System (Verdichter im Gebäude)					
				6 x VOII-1200-2LOW	
Flussigkeitsleitung (bis 8 Meter IE/AE)				6 x VOII-1200-2HIGH	
Saugleitung (bis 8 Meter IE/AE)				6 x VOII-1200-2LOW-DUCT	
Zusatzfüllung über 8 Meter Leitung				6 x VOII-1200-2HIGH-DUCT	
bei Luft - Wasser SPLIT Anlagen beinhaltet die Inneneinheit von Werk nur leichtes Überdruck vom Kältemittel was nach dem Betriebstest in der Wärmepumpe geblieben ist.					

WAMAK AW 300 EVI HeavyDuty 2L3

ErP (EU) No 811/2013: Technische Parameter für Wärmepumpen-Raumheizgeräte

Modell	AW 300 EVI HeavyDuty 2L3
Luft-Wasser-Wärmepumpe	ja
Sole/Wasser-Wärmepumpe	nein
Wasser/Wasser-Wärmepumpe	nein
Niedertemperatur-Wärmepumpe	nein
Ausgestattet mit einer Zusatzheizung	nein
Wärmepumpen-Kombi-Heizgerät	nein
Temperaturanwendung	niedrig (35 °C - 30 °C)
Klimaverhältnisse	durchschnittlich

Angabe	Symbol	Wert	Ein.	Angabe	Symbol	Wert	Ein.
Nennwärmeleistung bei Tdesignh	Prated	238.0	kW	Jahreszeitbedingte Raumheizungs-Energieeffizienz	η_s	169.4	%
Ausgewiesene Heizleistung für Teillast bei einer Innentemperatur von 20 °C und einer Außentemperatur von Tj				Deklarierte Leistungszahl oder Primärenergiekennzahl für Teillast bei einer Innentemperatur von 20 °C und einer Außentemperatur von Tj			
Tj = -7 °C	Pdh	209.9	kW	Tj = -7 °C	COPd	3.17	-
Tj = +2 °C	Pdh	247.5	kW	Tj = +2 °C	COPd	4.1	-
Tj = +7 °C	Pdh	291.6	kW	Tj = +7 °C	COPd	5.1	-
Tj = +12 °C	Pdh	344.7	kW	Tj = +12 °C	COPd	6.4	-
Tj = bivalente Temperatur	Pdh	206.4	kW	Tj = bivalente Temperatur	COPd	3.1	-
Tj = Betriebsgrenztemperatur	Pdh	150.5	kW	Tj = Betriebsgrenztemperatur	COPd	2.3	-
Bivalente Temperatur	Tbiv	-7	°C	Tj = Betriebsgrenztemperatur	TOL	-22	°C
Stromverbrauch in anderen Modi als dem aktiven Modus				Betriebsgrenztemperatur des Heizwassers			
Aus-Zustand	Poff	0.040	kW	Zusatzheizung			
Thermostat-Aus-Modus	Pto	0.010	kW	Nennwärmeleistung	Psup	105.5	kW
Standby-Betrieb	Psb	0.010	kW	Art der Energiezufuhr			
Betriebsart Kurbelwannenheizung	Pck	0.050	kW	elektrisch			
Sonstige Angaben				Für Luft/Wasser-Wärmepumpen: Nennluftvolumenstrom, Außenbereich			
Leistungsregelung		mehrstufig		Für Wasser- oder Sole/Wasser-Wärmepumpen: Nenndurchfluss der Sole oder des Wassers, Wärmetauscher im Freien		-	
Schalleistungspegel						15073 ~ 90440 m3/h	
in Innenräumen	Lwa	73	dB			---	
im Freien	Lwa	78	dB				
Jährlicher Energieverbrauch	QHE	115769.8	kWh				

Angaben zum Kontakt: WAMAK, s.r.o., Orovnic 252, 96652, Orovnic, Slovakia, info@wamak.sk

WAMAK AW 300 EVI HeavyDuty 2L3

ErP (EU) No 811/2013: Technische Parameter für Wärmepumpen-Raumheizgeräte

Modell	AW 300 EVI HeavyDuty 2L3
Luft-Wasser-Wärmepumpe	ja
Sole/Wasser-Wärmepumpe	nein
Wasser/Wasser-Wärmepumpe	nein
Niedertemperatur-Wärmepumpe	nein
Ausgestattet mit einer Zusatzheizung	nein
Wärmepumpen-Kombi-Heizgerät	nein
Temperaturanwendung	mittel (55 °C - 47 °C)
Klimaverhältnisse	durchschnittlich

Angabe	Symbol	Wert	Ein.	Angabe	Symbol	Wert	Ein.
Nennwärmeleistung bei Tdesignh	Prated	249.7	kW	Jahreszeitbedingte Raumheizungs-Energieeffizienz	η_s	132.5	%
Ausgewiesene Heizleistung für Teillast bei einer Innentemperatur von 20 °C und einer Außentemperatur von Tj				Deklarierte Leistungszahl oder Primärenergiekennzahl für Teillast bei einer Innentemperatur von 20 °C und einer Außentemperatur von Tj			
Tj = -7 °C	Pdh	219.4	kW	Tj = -7 °C	COPd	2.24	-
Tj = +2 °C	Pdh	253.5	kW	Tj = +2 °C	COPd	3.2	-
Tj = +7 °C	Pdh	294.8	kW	Tj = +7 °C	COPd	4.2	-
Tj = +12 °C	Pdh	345.4	kW	Tj = +12 °C	COPd	5.6	-
Tj = bivalente Temperatur	Pdh	216.8	kW	Tj = bivalente Temperatur	COPd	2.1	-
Tj = Betriebsgrenztemperatur	Pdh	158.7	kW	Tj = Betriebsgrenztemperatur	COPd	1.6	-
Bivalente Temperatur	Tbiv	-7	°C	Tj = Betriebsgrenztemperatur	TOL	-22	°C
Stromverbrauch in anderen Modi als dem aktiven Modus				Betriebsgrenztemperatur des Heizwassers	WTOL	65	°C
Aus-Zustand	Poff	0.040	kW	Zusatzheizung			
Thermostat-Aus-Modus	Pto	0.010	kW	Nennwärmeleistung	Psup	105.5	kW
Standby-Betrieb	Psb	0.010	kW	Art der Energiezufuhr			
Betriebsart Kurbelwannenheizung	Pck	0.050	kW	elektrisch			
Sonstige Angaben				Für Luft/Wasser-Wärmepumpen: - 15073 ~ 90440 m3/h			
Leistungsregelung				mehrstufig			
Schalleistungspegel				Für Wasser- oder Sole/Wasser-Wärmepumpen: Nenndurchfluss der Sole oder des Wassers, Wärmetauscher im Freien			
in Innenräumen	Lwa	73	dB	---			
im Freien	Lwa	78	dB				
Jährlicher Energieverbrauch	QHE	155370.5	kWh				

Angaben zum Kontakt: WAMAK, s.r.o., Orovnica 252, 96652, Orovnica, Slovakia, info@wamak.sk



ENERG Y IIA
 енергия - ενεργεια IE IA



AW 300 EVI

HeavyDuty 2L3

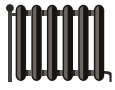

55 °C

35 °C

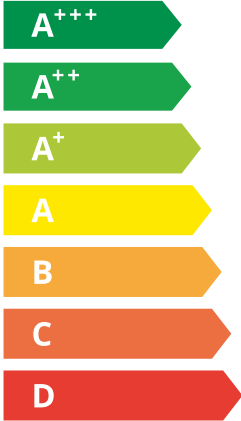

73 dB

78 dB

■ 263	■ 243
■ 250	■ 238
■ 245	■ 227
kW	kW

2019

811/2013

AW 300 EVI HeavyDuty
2L3

ErP Data

	55 °C	35 °C
Energy class	A++	A+++
η [%]	132.5	169.4
P_{rated} [kW]	250	238
Q_{HE} [kWh/y]	155371	115770
SCOP [-]	3.31	4.23
$T_{bivalent}$ [°C]	-7	-7

CONTROLLER



+ QAA55/75 class VII 3.5% ↓
 - QAA55/75 class III 1.5% ↓

Heizleistung Daten

Version: v2024.010-AW

Klimazone Durchschnitt / Niedrigtemp. [35°C]

ZHI46K1P-TWD_R410A_6_AW

Betriebsbedingungen		Qh	P	COP
1	A7 / W30-35	294.5	68.3	4.31
2	A2 / W35	250.2	68.2	3.67
3	A-22 / W35	150.5	65.0	2.31
A	A-7 / W34	209.9	66.3	3.17
B	A2 / W30	247.5	61.0	4.06
C	A7 / W27	291.6	57.1	5.11
D	A12 / W24	344.7	53.7	6.41
E	A-10 / W35	206.4	67.7	3.05
F	A-7 / W34	209.9	66.3	3.17

SCOP DATA EN 14825:2018	
Klimazone Durchschnitt / Niedrigtemp. [35°C]	
SCOPon	4.25
SCOPnet	4.28
SCOP	4.23
η [%]	169.36
Label	A+++
Qh [kWh]	115769.78
Pdesignh [kW]	238.0
Tbivalent [°C]	-7.00

Klimazone Durchschnitt / Mitteltemp. [55°C]

Betriebsbedingungen		Qh	P	COP
1	A7 / W47-55	300.5	107.1	2.81
2	A2 / W55	259.3	106.3	2.44
3	A-22 / W55	158.7	91.0	1.62
A	A-7 / W52	219.4	97.9	2.24
B	A2 / W42	253.5	79.6	3.18
C	A7 / W36	294.8	69.8	4.22
D	A12 / W30	345.4	61.3	5.64
E	A-10 / W55	216.8	104.4	2.08
F	A-7 / W55	220.9	104.6	2.11

SCOP DATA EN 14825:2018	
Klimazone Durchschnitt / Mitteltemp. [55°C]	
SCOPon	3.32
SCOPnet	3.34
SCOP	3.31
η [%]	132.50
Label	A++
Qh [kWh]	155370.52
Pdesignh [kW]	249.7
Tbivalent [°C]	-7.00

Kühlleistung Daten

Niedrigtemperatur Kühlung W 12 / 7°C

Betriebsbedingungen		Qc	P	EER
A	A35 / W12-7	218.3	81.6	2.68
B	A30 / W12-7	224.3	73.0	3.07
C	A25 / W12-7	229.4	65.3	3.51
D	A20 / W12-7	233.6	58.4	4.00

SEER DATA EN 14825:2018 [W 12 / 7°C]	
SEERon	3.43
SEER	3.42
Qc [kWh]	48080.85
η [%]	136.76

Flächenkühlung W 23 / 18°C

Betriebsbedingungen		Qc	P	EER
A	A35 / W23-18	290.6	81.6	3.56
B	A30 / W23-18	298.5	67.6	4.09
C	A25 / W23-18	305.4	60.7	4.67
D	A20 / W23-18	311.5	54.6	5.34

SEER DATA EN 14825:2018 [W 23 / 18°C]	
SEERon	4.57
SEER	4.55
Qc [kWh]	36110.25
η [%]	181.92

Leistungslinien - Heizen

- Qh-nom-35 — Qh-min-35 - - - Qh-max-65 — Qh-nom-45 — Qh-nom-55
- Qh-nom-65 — Pratedh-35 — Pratedh-55

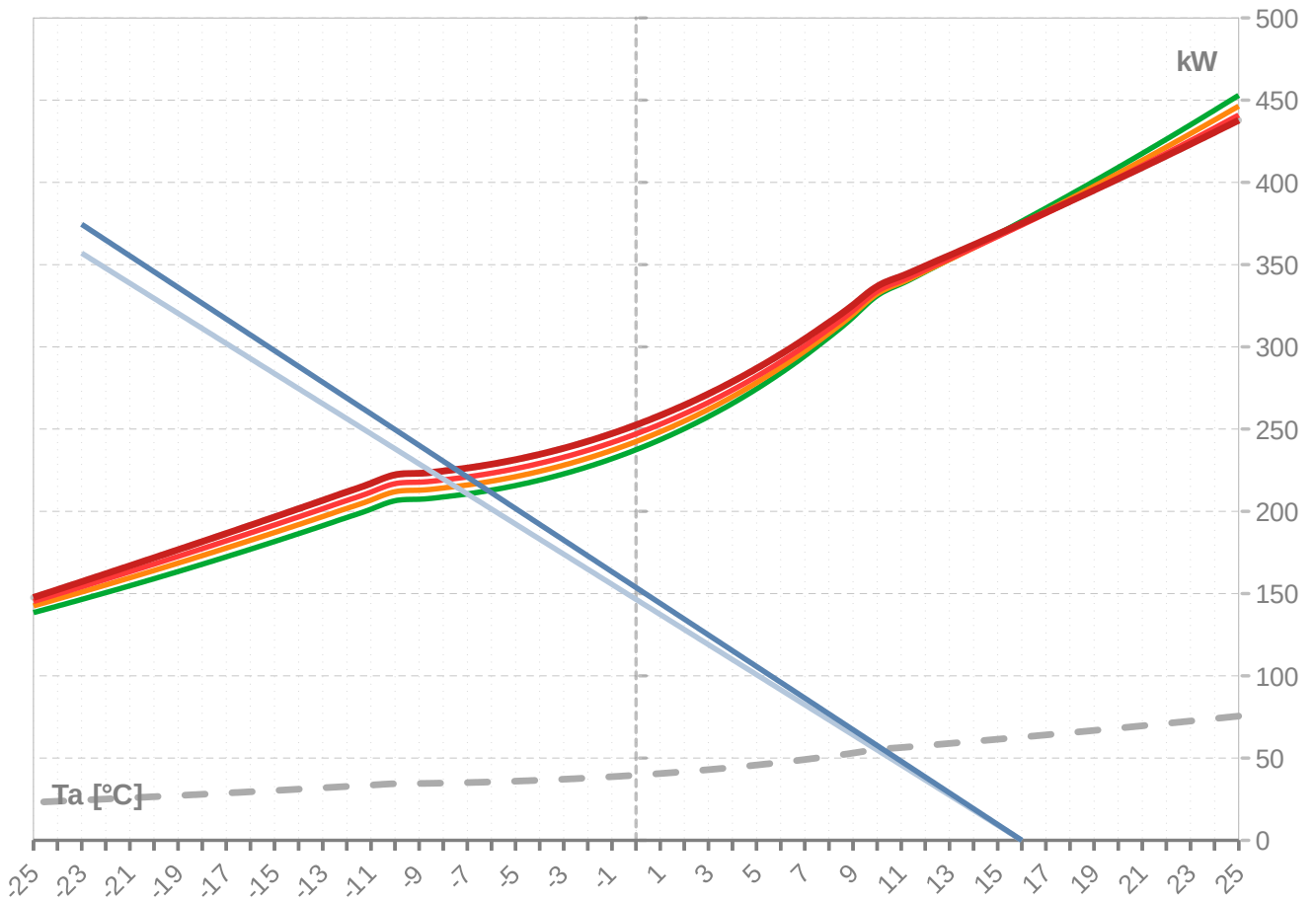

Leistungslinien - Kühlen

- Pratedc — Qc-12/7 — Qc-23/18

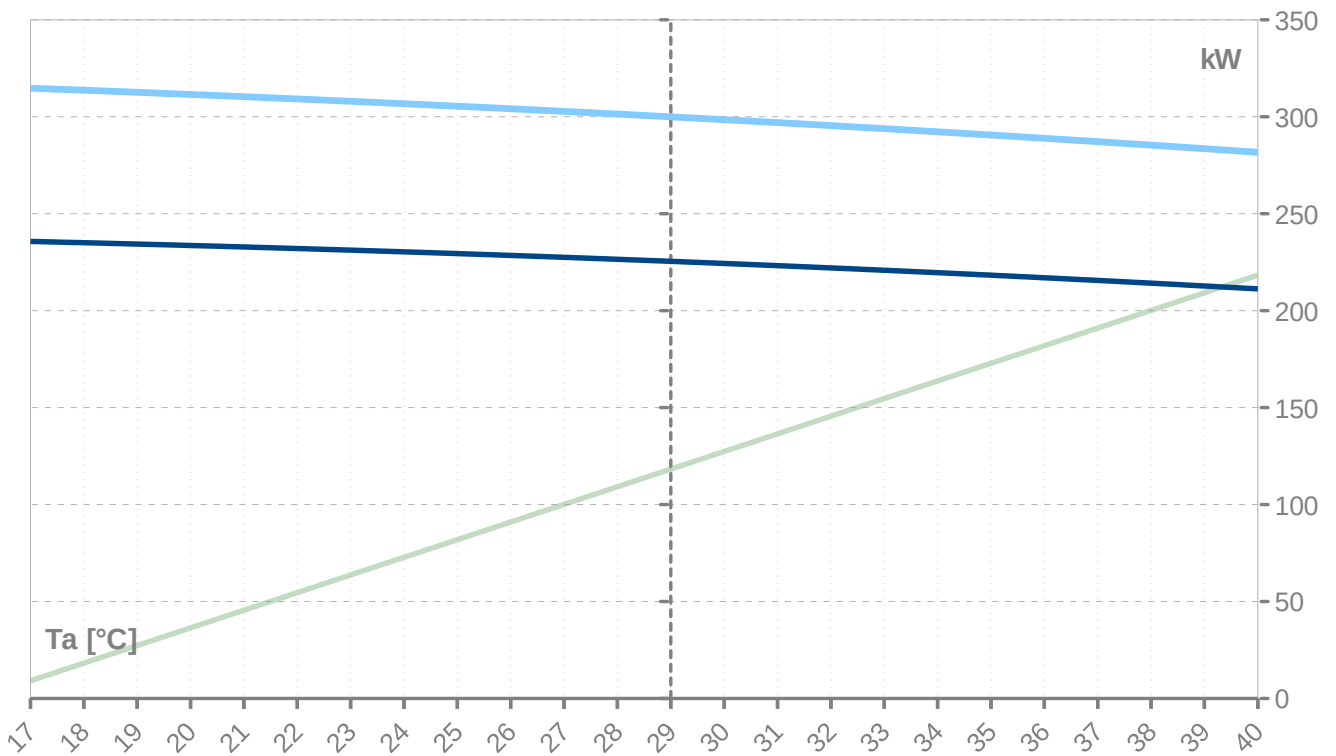

Th [°C]		35 °C								
Ta [°C]	Qh nom [kW]	Qh min [kW]	Qh max [kW]	Pin nom [kW]	Pin-min [kW]	Pin-max [kW]	COP kW / kW	I nom [A]	I min [A]	I max [A]
25	384.4	64.1		68.3	10.7		5.62	139.6	23.3	
24	384.4	64.1		68.3	10.7		5.62	139.6	23.3	
23	384.4	64.1		68.3	10.7		5.62	139.6	23.3	
22	384.4	64.1		68.3	10.7		5.62	139.6	23.3	
21	384.4	64.1		68.3	10.7		5.62	139.6	23.3	
20	384.4	64.1		68.3	10.7		5.62	139.6	23.3	
19	384.4	64.1		68.3	10.7		5.62	139.6	23.3	
18	384.4	64.1		68.3	10.7		5.62	139.6	23.3	
17	384.4	64.1		68.3	10.7		5.62	139.6	23.3	
16	376.4	62.7	376.4	68.3	10.7	68.3	5.51	139.7	23.3	139.7
15	368.5	61.4	368.5	68.3	10.7	68.3	5.40	139.9	23.3	139.9
14	360.8	60.1	360.8	68.3	10.7	68.3	5.28	140.0	23.3	140.0
13	353.2	58.9	353.2	68.3	10.7	68.3	5.17	140.1	23.4	140.1
12	345.7	57.6	345.7	68.3	10.7	68.3	5.06	140.3	23.4	140.3
11	338.3	56.4	338.3	68.3	10.7	68.3	4.96	140.4	23.4	140.4
10	331.1	55.2	331.1	68.3	10.7	68.3	4.85	140.6	23.4	140.6
9	318.0	53.0	318.0	68.3	10.7	68.3	4.66	140.9	23.5	140.9
8	305.9	51.0	305.9	68.3	10.7	68.3	4.48	141.2	23.5	141.2
7	294.5	49.1	294.5	68.3	10.7	68.3	4.31	141.4	23.6	141.4
6	284.1	47.3	284.1	68.3	10.7	68.3	4.16	141.7	23.6	141.7
5	274.5	45.7	274.5	68.3	10.7	68.3	4.02	141.9	23.7	141.9
4	265.6	44.3	265.6	68.3	10.7	68.3	3.89	142.1	23.7	142.1
3	257.6	42.9	257.6	68.3	10.7	68.3	3.77	142.2	23.7	142.2
2	250.2	41.7	250.2	68.2	10.7	68.2	3.67	142.3	23.7	142.3
1	243.5	40.6	243.5	68.2	10.7	68.2	3.57	142.4	23.7	142.4
0	237.4	39.6	237.4	68.1	10.7	68.1	3.49	142.5	23.7	142.5
-1	232.0	38.7	232.0	68.1	10.7	68.1	3.41	142.5	23.7	142.5
-2	227.1	37.9	227.1	68.0	10.7	68.0	3.34	142.5	23.7	142.5
-3	222.8	37.1	222.8	68.0	10.6	68.0	3.28	142.5	23.7	142.5
-4	219.0	36.5	219.0	67.9	10.6	67.9	3.22	142.4	23.7	142.4
-5	215.7	35.9	215.7	67.9	10.6	67.9	3.18	142.4	23.7	142.4
-6	212.9	35.5	212.9	67.8	10.6	67.8	3.14	142.4	23.7	142.4
-7	210.6	35.1	210.6	67.8	10.6	67.8	3.11	142.3	23.7	142.3
-8	208.7	34.8	208.7	67.7	10.6	67.7	3.08	142.3	23.7	142.3
-9	207.3	34.6	207.3	67.7	10.6	67.7	3.06	142.3	23.7	142.3
-10	206.4	34.4	206.4	67.7	10.6	67.7	3.05	142.2	23.7	142.2
-11	201.3	33.5	201.3	67.5	10.6	67.5	2.98	142.1	23.7	142.1
-12	196.2	32.7	196.2	67.4	10.6	67.4	2.91	141.9	23.7	141.9
-13	191.3	31.9	191.3	67.2	10.5	67.2	2.84	141.7	23.6	141.7
-14	186.4	31.1	186.4	67.1	10.5	67.1	2.78	141.5	23.6	141.5
-15	181.6	30.3	181.6	66.9	10.5	66.9	2.72	141.2	23.5	141.2
-16	176.9	29.5	176.9	66.7	10.4	66.7	2.65	140.9	23.5	140.9
-17	172.3	28.7	172.3	66.5	10.4	66.5	2.59	140.5	23.4	140.5
-18	167.8	28.0	167.8	66.2	10.4	66.2	2.53	140.1	23.3	140.1
-19	163.4	27.2	163.4	66.0	10.3	66.0	2.48	139.6	23.3	139.6
-20	159.0	26.5	159.0	65.7	10.3	65.7	2.42	139.1	23.2	139.1
-21	154.7	25.8	154.7	65.4	10.2	65.4	2.37	138.5	23.1	138.5
-22	150.5	25.1	150.5	65.0	10.2	65.0	2.31	137.9	23.0	137.9
-23	146.4	24.4	146.4	64.7	10.1	64.7	2.26	137.2	22.9	137.2
-24	142.4	23.7	142.4	64.3	10.1	64.3	2.21	136.5	22.8	136.5
-25	138.4	23.1	138.4	63.9	10.0	63.9	2.17	135.7	22.6	135.7

* Achtung: Betriebsgrenzen beachten - nicht in Tabelle festgehalten

ZHI46K1P-TWD_R410A_6_AW

Th [°C]		45 °C								
Ta [°C]	Qh nom [kW]	Qh min [kW]	Qh max [kW]	Pin nom [kW]	Pin-min [kW]	Pin-max [kW]	COP kW / kW	I nom [A]	I min [A]	I max [A]
25	446.4	74.4	446.4	84.7	13.3	84.7	5.27	159.2	26.5	159.2
24	438.0	73.0	438.0	84.7	13.3	84.7	5.17	159.1	26.5	159.1
23	429.7	71.6	429.7	84.7	13.3	84.7	5.07	159.1	26.5	159.1
22	421.5	70.2	421.5	84.7	13.3	84.7	4.98	159.1	26.5	159.1
21	413.4	68.9	413.4	84.7	13.3	84.7	4.88	159.1	26.5	159.1
20	405.5	67.6	405.5	84.8	13.3	84.8	4.78	159.2	26.5	159.2
19	397.7	66.3	397.7	84.8	13.3	84.8	4.69	159.2	26.5	159.2
18	389.9	65.0	389.9	84.9	13.3	84.9	4.60	159.3	26.5	159.3
17	382.3	63.7	382.3	84.9	13.3	84.9	4.50	159.3	26.6	159.3
16	374.9	62.5	374.9	84.9	13.3	84.9	4.41	159.4	26.6	159.4
15	367.5	61.2	367.5	85.0	13.3	85.0	4.32	159.4	26.6	159.4
14	360.2	60.0	360.2	85.0	13.3	85.0	4.24	159.5	26.6	159.5
13	353.1	58.8	353.1	85.1	13.3	85.1	4.15	159.6	26.6	159.6
12	346.0	57.7	346.0	85.1	13.3	85.1	4.07	159.6	26.6	159.6
11	339.1	56.5	339.1	85.1	13.3	85.1	3.98	159.7	26.6	159.7
10	332.2	55.4	332.2	85.2	13.3	85.2	3.90	159.8	26.6	159.8
9	319.8	53.3	319.8	85.2	13.3	85.2	3.75	159.9	26.6	159.9
8	308.3	51.4	308.3	85.3	13.4	85.3	3.62	159.9	26.7	159.9
7	297.4	49.6	297.4	85.3	13.4	85.3	3.49	159.9	26.7	159.9
6	287.5	47.9	287.5	85.3	13.4	85.3	3.37	159.9	26.7	159.9
5	278.2	46.4	278.2	85.2	13.4	85.2	3.26	159.8	26.6	159.8
4	269.8	45.0	269.8	85.2	13.3	85.2	3.17	159.7	26.6	159.7
3	262.0	43.7	262.0	85.1	13.3	85.1	3.08	159.6	26.6	159.6
2	254.8	42.5	254.8	85.0	13.3	85.0	3.00	159.4	26.6	159.4
1	248.3	41.4	248.3	85.0	13.3	85.0	2.92	159.2	26.5	159.2
0	242.4	40.4	242.4	84.8	13.3	84.8	2.86	159.0	26.5	159.0
-1	237.1	39.5	237.1	84.7	13.3	84.7	2.80	158.8	26.5	158.8
-2	232.3	38.7	232.3	84.6	13.3	84.6	2.74	158.6	26.4	158.6
-3	228.0	38.0	228.0	84.5	13.2	84.5	2.70	158.3	26.4	158.3
-4	224.3	37.4	224.3	84.4	13.2	84.4	2.66	158.1	26.4	158.1
-5	221.1	36.8	221.1	84.3	13.2	84.3	2.62	157.9	26.3	157.9
-6	218.3	36.4	218.3	84.2	13.2	84.2	2.59	157.7	26.3	157.7
-7	216.0	36.0	216.0	84.1	13.2	84.1	2.57	157.5	26.3	157.5
-8	214.2	35.7	214.2	84.1	13.2	84.1	2.55	157.4	26.2	157.4
-9	212.8	35.5	212.8	84.0	13.2	84.0	2.53	157.3	26.2	157.3
-10	211.9	35.3	211.9	84.0	13.2	84.0	2.52	157.2	26.2	157.2
-11	206.8	34.5	206.8	83.8	13.1	83.8	2.47	156.7	26.1	156.7
-12	201.8	33.6	201.8	83.5	13.1	83.5	2.42	156.2	26.0	156.2
-13	196.8	32.8	196.8	83.3	13.0	83.3	2.36	155.7	25.9	155.7
-14	191.9	32.0	191.9	83.0	13.0	83.0	2.31	155.1	25.8	155.1
-15	187.1	31.2	187.1	82.7	12.9	82.7	2.26	154.4	25.7	154.4
-16	182.3	30.4	182.3	82.3	12.9	82.3	2.21	153.7	25.6	153.7
-17	177.7	29.6	177.7	82.0	12.8	82.0	2.17	153.0	25.5	153.0
-18	173.0	28.8	173.0	81.6	12.8	81.6	2.12	152.2	25.4	152.2
-19	168.5	28.1	168.5	81.2	12.7	81.2	2.07	151.3	25.2	151.3
-20	164.0	27.3	164.0	80.8	12.7	80.8	2.03	150.4	25.1	150.4
-21	159.6	26.6	159.6	80.3	12.6	80.3	1.99	149.4	24.9	149.4
-22	155.2	25.9	155.2	79.8	12.5	79.8	1.94	148.3	24.7	148.3
-23	150.9	25.2	150.9	79.3	12.4	79.3	1.90	147.2	24.5	147.2
-24	146.7	24.4	146.7	78.8	12.3	78.8	1.86	146.0	24.3	146.0
-25	142.5	23.7	142.5	78.2	12.2	78.2	1.82	144.7	24.1	144.7

* Achtung: Betriebsgrenzen beachten - nicht in Tabelle festgehalten

WAMAK AW 300 EVI HeavyDuty 2L3

Th [°C]		55 °C								
Ta [°C]	Qh nom [kW]	Qh min [kW]	Qh max [kW]	Pin nom [kW]	Pin-min [kW]	Pin-max [kW]	COP kW / kW	I nom [A]	I min [A]	I max [A]
25	441.0	73.5	441.0	106.3	16.7	106.3	4.15	183.9	30.7	183.9
24	433.1	72.2	433.1	106.4	16.7	106.4	4.07	184.0	30.7	184.0
23	425.4	70.9	425.4	106.5	16.7	106.5	3.99	184.0	30.7	184.0
22	417.8	69.6	417.8	106.6	16.7	106.6	3.92	184.1	30.7	184.1
21	410.2	68.4	410.2	106.6	16.7	106.6	3.85	184.1	30.7	184.1
20	402.8	67.1	402.8	106.7	16.7	106.7	3.77	184.2	30.7	184.2
19	395.5	65.9	395.5	106.8	16.7	106.8	3.70	184.3	30.7	184.3
18	388.2	64.7	388.2	106.8	16.7	106.8	3.63	184.3	30.7	184.3
17	381.1	63.5	381.1	106.9	16.7	106.9	3.56	184.4	30.7	184.4
16	374.1	62.3	374.1	107.0	16.8	107.0	3.50	184.5	30.7	184.5
15	367.1	61.2	367.1	107.0	16.8	107.0	3.43	184.5	30.8	184.5
14	360.3	60.0	360.3	107.1	16.8	107.1	3.36	184.6	30.8	184.6
13	353.5	58.9	353.5	107.1	16.8	107.1	3.30	184.6	30.8	184.6
12	346.8	57.8	346.8	107.1	16.8	107.1	3.24	184.6	30.8	184.6
11	340.2	56.7	340.2	107.2	16.8	107.2	3.17	184.6	30.8	184.6
10	333.7	55.6	333.7	107.2	16.8	107.2	3.11	184.6	30.8	184.6
9	322.0	53.7	322.0	107.2	16.8	107.2	3.00	184.6	30.8	184.6
8	310.9	51.8	310.9	107.2	16.8	107.2	2.90	184.5	30.7	184.5
7	300.5	50.1	300.5	107.1	16.8	107.1	2.81	184.3	30.7	184.3
6	290.9	48.5	290.9	107.0	16.8	107.0	2.72	184.1	30.7	184.1
5	282.0	47.0	282.0	106.9	16.7	106.9	2.64	183.8	30.6	183.8
4	273.8	45.6	273.8	106.7	16.7	106.7	2.57	183.5	30.6	183.5
3	266.2	44.4	266.2	106.5	16.7	106.5	2.50	183.1	30.5	183.1
2	259.3	43.2	259.3	106.3	16.7	106.3	2.44	182.7	30.5	182.7
1	252.9	42.1	252.9	106.1	16.6	106.1	2.38	182.3	30.4	182.3
0	247.1	41.2	247.1	105.9	16.6	105.9	2.33	181.9	30.3	181.9
-1	241.8	40.3	241.8	105.7	16.6	105.7	2.29	181.5	30.2	181.5
-2	237.1	39.5	237.1	105.5	16.5	105.5	2.25	181.0	30.2	181.0
-3	232.9	38.8	232.9	105.3	16.5	105.3	2.21	180.6	30.1	180.6
-4	229.2	38.2	229.2	105.1	16.5	105.1	2.18	180.2	30.0	180.2
-5	225.9	37.7	225.9	104.9	16.4	104.9	2.15	179.8	30.0	179.8
-6	223.2	37.2	223.2	104.8	16.4	104.8	2.13	179.5	29.9	179.5
-7	220.9	36.8	220.9	104.6	16.4	104.6	2.11	179.2	29.9	179.2
-8	219.1	36.5	219.1	104.5	16.4	104.5	2.10	179.0	29.8	179.0
-9	217.7	36.3	217.7	104.4	16.4	104.4	2.09	178.8	29.8	178.8
-10	216.8	36.1	216.8	104.4	16.3	104.4	2.08	178.7	29.8	178.7
-11	211.7	35.3	211.7	104.0	16.3	104.0	2.04	177.9	29.7	177.9
-12	206.6	34.4	206.6	103.6	16.2	103.6	1.99	177.1	29.5	177.1
-13	201.6	33.6	201.6	103.2	16.2	103.2	1.95	176.3	29.4	176.3
-14	196.6	32.8	196.6	102.7	16.1	102.7	1.91	175.4	29.2	175.4
-15	191.7	31.9	191.7	102.3	16.0	102.3	1.87	174.4	29.1	174.4
-16	186.8	31.1	186.8	101.8	15.9	101.8	1.84	173.4	28.9	173.4
-17	182.0	30.3	182.0	101.2	15.9	101.2	1.80	172.3	28.7	172.3
-18	177.3	29.5	177.3	100.7	15.8	100.7	1.76	171.1	28.5	171.1
-19	172.6	28.8	172.6	100.1	15.7	100.1	1.72	169.9	28.3	169.9
-20	167.9	28.0	167.9	99.4	15.6	99.4	1.69	168.6	28.1	168.6
-21	163.3	27.2	163.3	98.8	15.5	98.8	1.65	167.2	27.9	167.2
-22	158.7	26.4	158.7	98.1	15.4	98.1	1.62	165.7	27.6	165.7
-23	154.1	25.7	154.1	97.3	15.2	97.3	1.58	164.2	27.4	164.2
-24	149.6	24.9	149.6	96.6	15.1	96.6	1.55	162.6	27.1	162.6
-25	145.2	24.2	145.2	95.8	15.0	95.8	1.52	160.9	26.8	160.9

* Achtung: Betriebsgrenzen beachten - nicht in Tabelle festgehalten

WAMAK AW 300 EVI HeavyDuty 2L3

Th [°C]		T-Max @ 65 °C								
Ta [°C]	Qh nom [kW]	Qh min [kW]	Qh max [kW]	Pin nom [kW]	Pin-min [kW]	Pin-max [kW]	COP kW / kW	I nom [A]	I min [A]	I max [A]
25	437.8	73.0	437.8	135.6	21.2	135.6	3.23	216.8	36.1	216.8
24	430.5	71.8	430.5	135.7	21.2	135.7	3.17	217.0	36.2	217.0
23	423.3	70.5	423.3	135.7	21.3	135.7	3.12	217.2	36.2	217.2
22	416.1	69.4	416.1	135.8	21.3	135.8	3.06	217.3	36.2	217.3
21	409.1	68.2	409.1	135.9	21.3	135.9	3.01	217.5	36.2	217.5
20	402.1	67.0	402.1	135.9	21.3	135.9	2.96	217.6	36.3	217.6
19	395.2	65.9	395.2	136.0	21.3	136.0	2.91	217.7	36.3	217.7
18	388.4	64.7	388.4	136.0	21.3	136.0	2.86	217.9	36.3	217.9
17	381.7	63.6	381.7	136.1	21.3	136.1	2.81	218.0	36.3	218.0
16	375.1	62.5	375.1	136.1	21.3	136.1	2.76	218.1	36.3	218.1
15	368.5	61.4	368.5	136.1	21.3	136.1	2.71	218.2	36.4	218.2
14	362.0	60.3	362.0	136.1	21.3	136.1	2.66	218.2	36.4	218.2
13	355.6	59.3	355.6	136.1	21.3	136.1	2.61	218.3	36.4	218.3
12	349.3	58.2	349.3	136.1	21.3	136.1	2.57	218.3	36.4	218.3
11	343.0	57.2	343.0	136.0	21.3	136.0	2.52	218.3	36.4	218.3
10	336.8	56.1	336.8	136.0	21.3	136.0	2.48	218.3	36.4	218.3
9	325.5	54.2	325.5	135.9	21.3	135.9	2.40	218.2	36.4	218.2
8	314.9	52.5	314.9	135.7	21.2	135.7	2.32	218.0	36.3	218.0
7	304.9	50.8	304.9	135.4	21.2	135.4	2.25	217.7	36.3	217.7
6	295.5	49.3	295.5	135.2	21.2	135.2	2.19	217.4	36.2	217.4
5	286.9	47.8	286.9	134.9	21.1	134.9	2.13	216.9	36.2	216.9
4	278.8	46.5	278.8	134.5	21.1	134.5	2.07	216.4	36.1	216.4
3	271.4	45.2	271.4	134.2	21.0	134.2	2.02	215.9	36.0	215.9
2	264.6	44.1	264.6	133.8	21.0	133.8	1.98	215.3	35.9	215.3
1	258.3	43.0	258.3	133.5	20.9	133.5	1.94	214.7	35.8	214.7
0	252.5	42.1	252.5	133.1	20.8	133.1	1.90	214.1	35.7	214.1
-1	247.3	41.2	247.3	132.7	20.8	132.7	1.86	213.5	35.6	213.5
-2	242.6	40.4	242.6	132.4	20.7	132.4	1.83	212.9	35.5	212.9
-3	238.4	39.7	238.4	132.0	20.7	132.0	1.81	212.4	35.4	212.4
-4	234.6	39.1	234.6	131.7	20.6	131.7	1.78	211.8	35.3	211.8
-5	231.4	38.6	231.4	131.4	20.6	131.4	1.76	211.3	35.2	211.3
-6	228.6	38.1	228.6	131.1	20.5	131.1	1.74	210.9	35.1	210.9
-7	226.3	37.7	226.3	130.9	20.5	130.9	1.73	210.5	35.1	210.5
-8	224.5	37.4	224.5	130.7	20.5	130.7	1.72	210.2	35.0	210.2
-9	223.1	37.2	223.1	130.6	20.5	130.6	1.71	209.9	35.0	209.9
-10	222.2	37.0	222.2	130.5	20.4	130.5	1.70	209.8	35.0	209.8
-11	217.0	36.2	217.0	130.0	20.4	130.0	1.67	208.8	34.8	208.8
-12	211.8	35.3	211.8	129.4	20.3	129.4	1.64	207.7	34.6	207.7
-13	206.7	34.4	206.7	128.7	20.2	128.7	1.61	206.6	34.4	206.6
-14	201.6	33.6	201.6	128.1	20.1	128.1	1.57	205.5	34.2	205.5
-15	196.5	32.8	196.5	127.4	20.0	127.4	1.54	204.2	34.0	204.2
-16										
-17										
-18										
-19										
-20										
-21										
-22										
-23										
-24										
-25										

* Achtung: Betriebsgrenzen beachten - nicht in Tabelle festgehalten

WAMAK AW 300 EVI HeavyDuty 2L3

Tc [°C]		W 12 / 7 °C								
Ta [°C]	Qc nom [kW]	Qc min [kW]	Qc max [kW]	Pin [kW]	Pin min [kW]	Pin max [kW]	EER kW / kW	I nom [A]	I min [A]	I max [A]
40	211.2	211.2	211.2	91.2	85.7	91.2	2.32	166.4	166.4	166.4
39	212.7	212.7	212.7	89.2	83.8	89.2	2.38	164.2	164.2	164.2
38	214.2	214.2	214.2	87.2	82.0	87.2	2.46	162.0	162.0	162.0
37	215.6	215.6	215.6	85.3	80.1	85.3	2.53	159.9	159.9	159.9
36	217.0	217.0	217.0	83.4	78.4	83.4	2.60	157.9	157.9	157.9
35	218.3	218.3	218.3	81.6	76.6	81.6	2.68	155.9	155.9	155.9
34	219.6	219.6	219.6	79.8	75.0	79.8	2.75	153.9	153.9	153.9
33	220.8	220.8	220.8	78.0	73.3	78.0	2.83	152.0	152.0	152.0
32	222.0	222.0	222.0	76.3	71.7	76.3	2.91	150.2	150.2	150.2
31	223.2	223.2	223.2	74.6	70.1	74.6	2.99	148.4	148.4	148.4
30	224.3	224.3	224.3	73.0	68.6	73.0	3.07	146.7	146.7	146.7
29	225.4	225.4	225.4	71.4	67.1	71.4	3.16	144.9	144.9	144.9
28	226.5	226.5	226.5	69.8	65.6	69.8	3.24	143.2	143.2	143.2
27	227.5	227.5	227.5	68.3	64.2	68.3	3.33	141.6	141.6	141.6
26	228.5	228.5	228.5	66.8	62.8	66.8	3.42	140.0	140.0	140.0
25	229.4	229.4	229.4	65.3	61.4	65.3	3.51	138.4	138.4	138.4
24	230.3	230.3	230.3	63.9	60.0	63.9	3.60	136.8	136.8	136.8
23	231.2	231.2	231.2	62.5	58.7	62.5	3.70	135.2	135.2	135.2
22	232.0	232.0	232.0	61.1	57.4	61.1	3.80	133.7	133.7	133.7
21	232.8	232.8	232.8	59.7	56.1	59.7	3.90	132.2	132.2	132.2
20	233.6	233.6	233.6	58.4	54.8	58.4	4.00	130.7	130.7	130.7
19	234.3	234.3	234.3	57.0	53.6	57.0	4.11	129.2	129.2	129.2
18	235.0	235.0	235.0	55.7	52.4	55.7	4.22	127.6	127.6	127.6
17	235.7	235.7	235.7	54.4	51.1	54.4	4.33	126.1	126.1	126.1

Tc [°C]		W 23 / 18 °C								
Ta [°C]	Qc [kW]	Qh-min [kW]	Qh-max [kW]	Pin [kW]	Pin-min [kW]	Pin-max [kW]	EER kW / kW	I [A]	I-min [A]	I-max [A]
40	281.7	281.7	281.7	91.2	85.7	91.2	3.09	166.3	166.3	166.3
39	283.5	283.5	283.5	89.2	83.8	89.2	3.18	164.0	164.0	164.0
38	285.3	285.3	285.3	87.2	82.0	87.2	3.27	161.7	161.7	161.7
37	287.1	287.1	287.1	85.3	80.1	85.3	3.37	159.5	159.5	159.5
36	288.9	288.9	288.9	83.4	78.4	83.4	3.46	157.3	157.3	157.3
35	290.6	290.6	290.6	81.6	76.6	81.6	3.56	155.2	155.2	155.2
34	292.2	292.2	292.2	79.8	75.0	79.8	3.66	153.2	153.2	153.2
33	293.8	293.8	293.8	78.0	73.3	78.0	3.77	151.2	151.2	151.2
32	295.4	295.4	295.4	76.3	71.7	76.3	3.87	149.2	149.2	149.2
31	297.0	297.0	297.0	74.6	70.1	74.6	3.98	147.3	147.3	147.3
30	298.5	298.5	298.5	73.0	68.6	73.0	4.09	145.4	145.4	145.4
29	299.9	299.9	299.9	71.4	67.1	71.4	4.20	143.6	143.6	143.6
28	301.4	301.4	301.4	69.8	65.6	69.8	4.32	141.7	141.7	141.7
27	302.8	302.8	302.8	68.3	64.2	68.3	4.43	139.9	139.9	139.9
26	304.1	304.1	304.1	66.8	62.8	66.8	4.55	138.2	138.2	138.2
25	305.4	305.4	305.4	65.3	61.4	65.3	4.67	136.4	136.4	136.4
24	306.7	306.7	306.7	63.9	60.0	63.9	4.80	134.7	134.7	134.7
23	308.0	308.0	308.0	62.5	58.7	62.5	4.93	133.0	133.0	133.0
22	309.2	309.2	309.2	61.1	57.4	61.1	5.06	131.3	131.3	131.3
21	310.3	310.3	310.3	59.7	56.1	59.7	5.20	129.6	129.6	129.6
20	311.5	311.5	311.5	58.4	54.8	58.4	5.34	127.9	127.9	127.9
19	312.6	312.6	312.6	57.0	53.6	57.0	5.48	126.2	126.2	126.2
18	313.7	313.7	313.7	55.7	52.4	55.7	5.63	124.5	124.5	124.5
17	314.7	314.7	314.7	54.4	51.1	54.4	5.78	122.8	122.8	122.8

* Achtung: Betriebsgrenzen beachten - nicht in Tabelle festgehalten

LEGENDE:

Twq-RL: Temperatur Wärmequelle - Eintritt [°C]

Tws-VL: Temperatur Wärmesenke - Vorlauf [°C]

Tk-VL: Temperatur Kältesenke - Vorlauf [°C]

Qh nom: Heizleistung nominal

Qh min: Heizleistung minimal

Qh max: Heizleistung maximal

Pin nom: Aufnahme bei nominaler Heizleistung

Pin min: Aufnahme bei minimaler Heizleistung

Pin max: Aufnahme bei maximaler Heizleistung

COP nom: Arbeitszahl bei nominaler Heizleistung

Qc nom: Kälteleistung/Energieentnahme bei nominaler Heizleistung

Qc min: Kälteleistung/Energieentnahme bei minimaler Heizleistung

Qc max: Kälteleistung/Energieentnahme bei maximaler Heizleistung

I nom: Stromaufnahme bei nominaler Heizleistung

EER: Arbeitszahl bei nominaler Kälteleistung

Betriebsgrenzen

°C

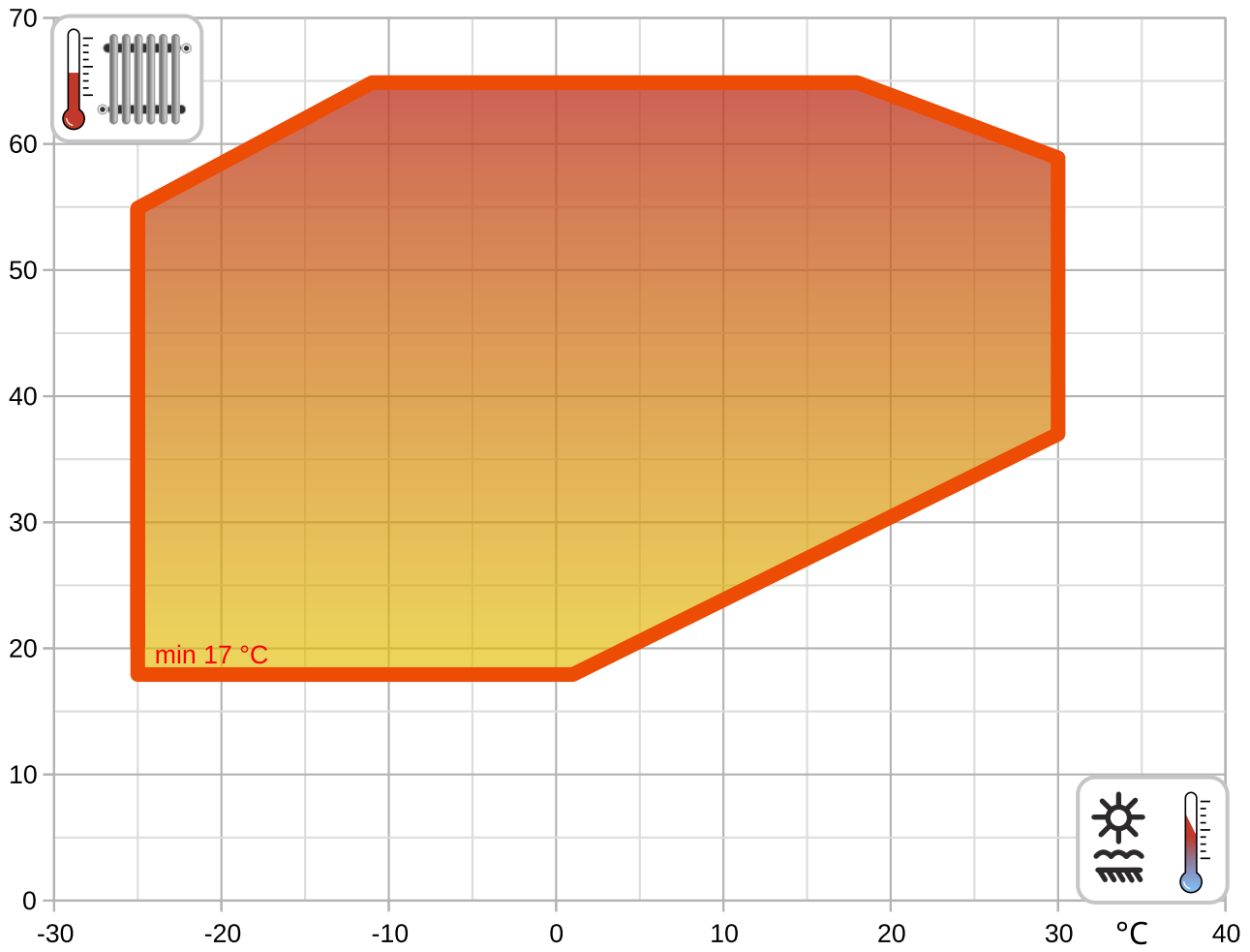

°C

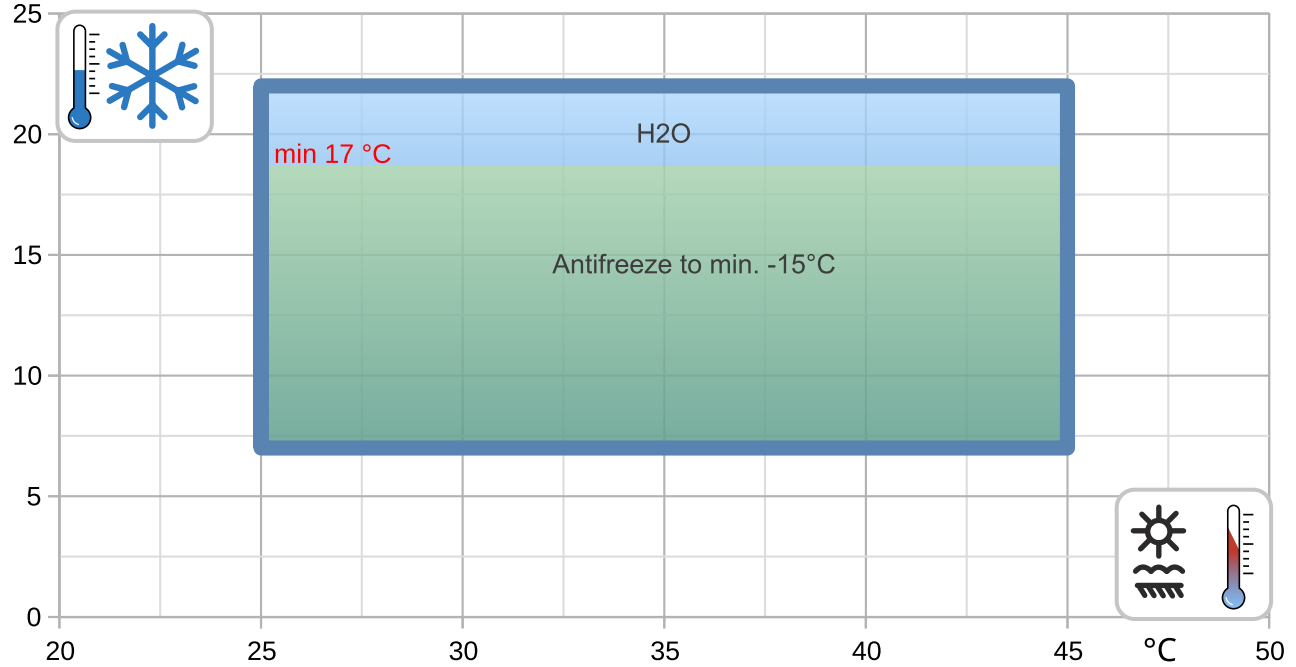

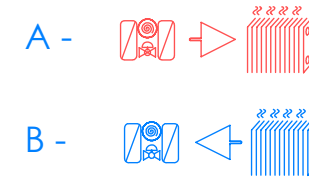
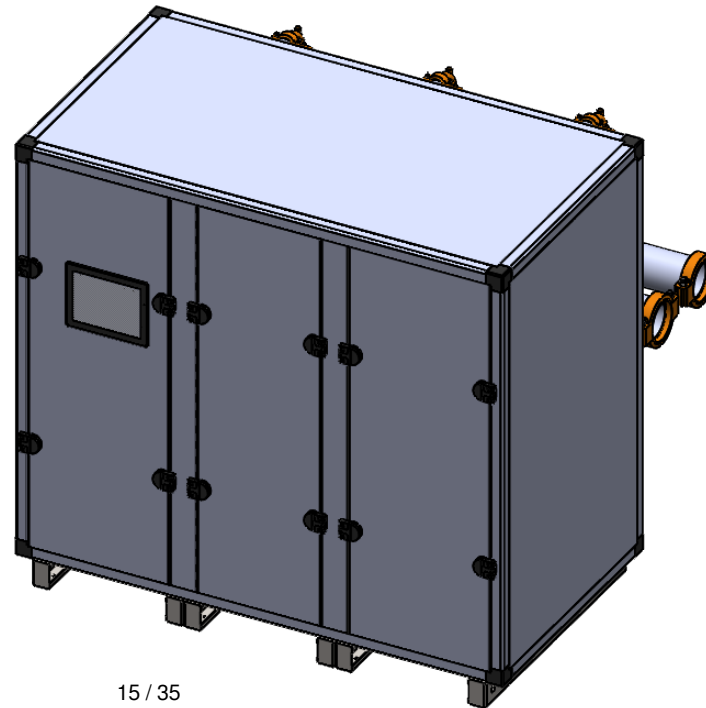
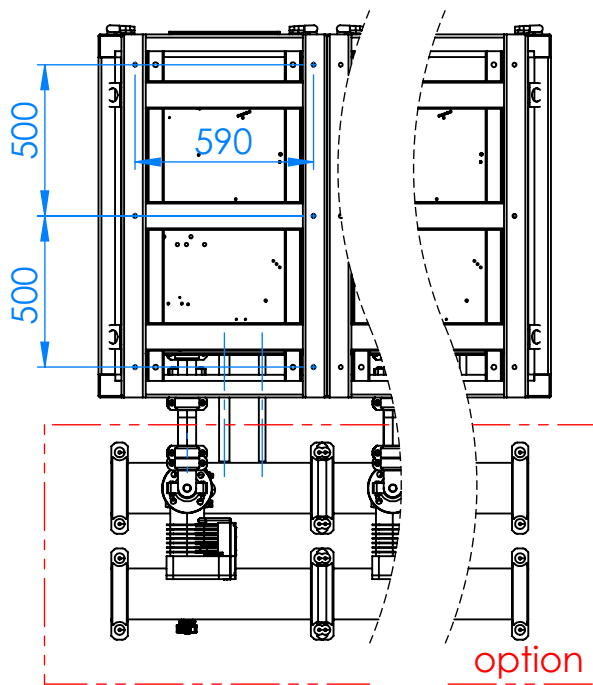
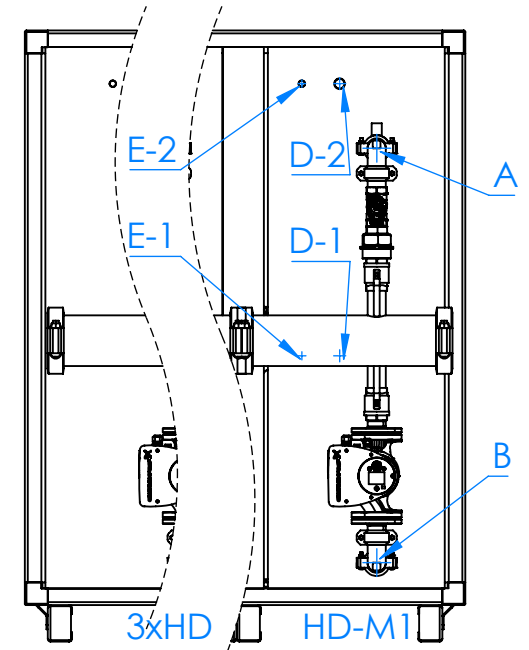
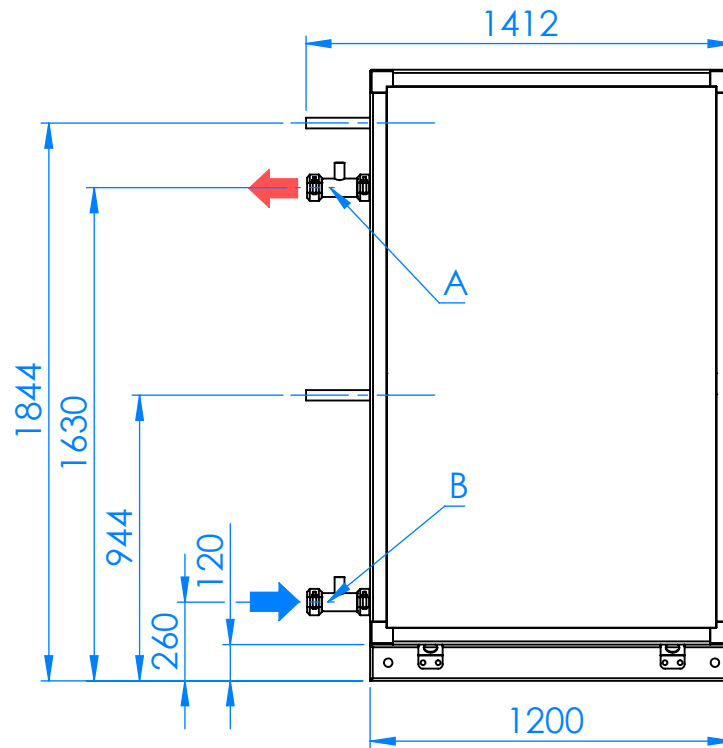
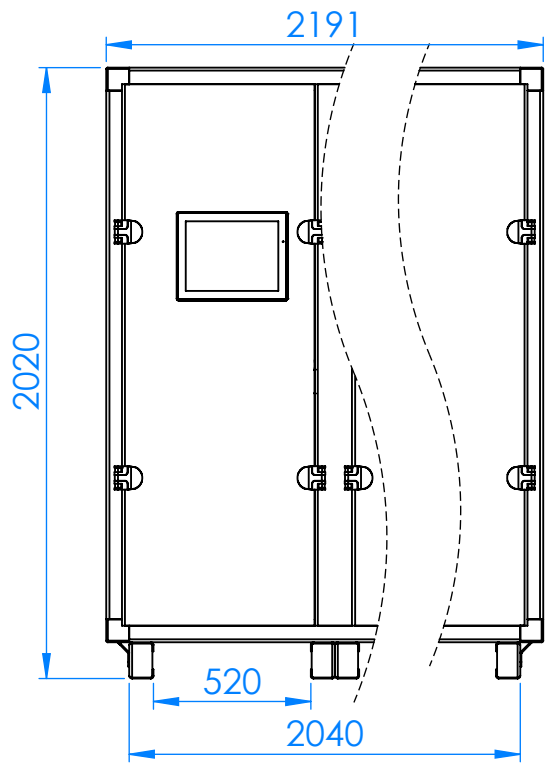

D (1,2,x) - SPLIT - FRIGO GAS
(Modul 1-2-x)

E (1,2,x) - SPLIT - FRIGO LIQUID
(Modul 1-2-x)

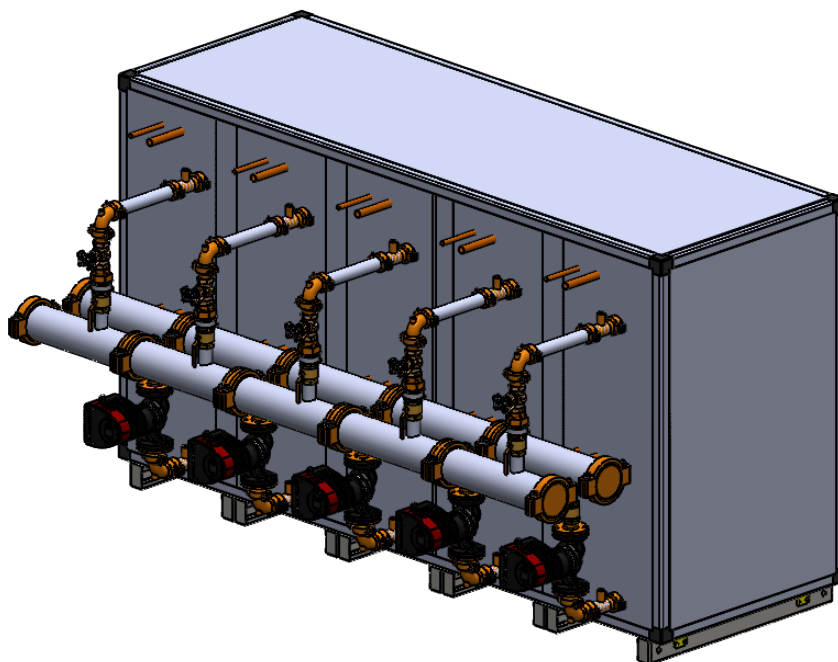
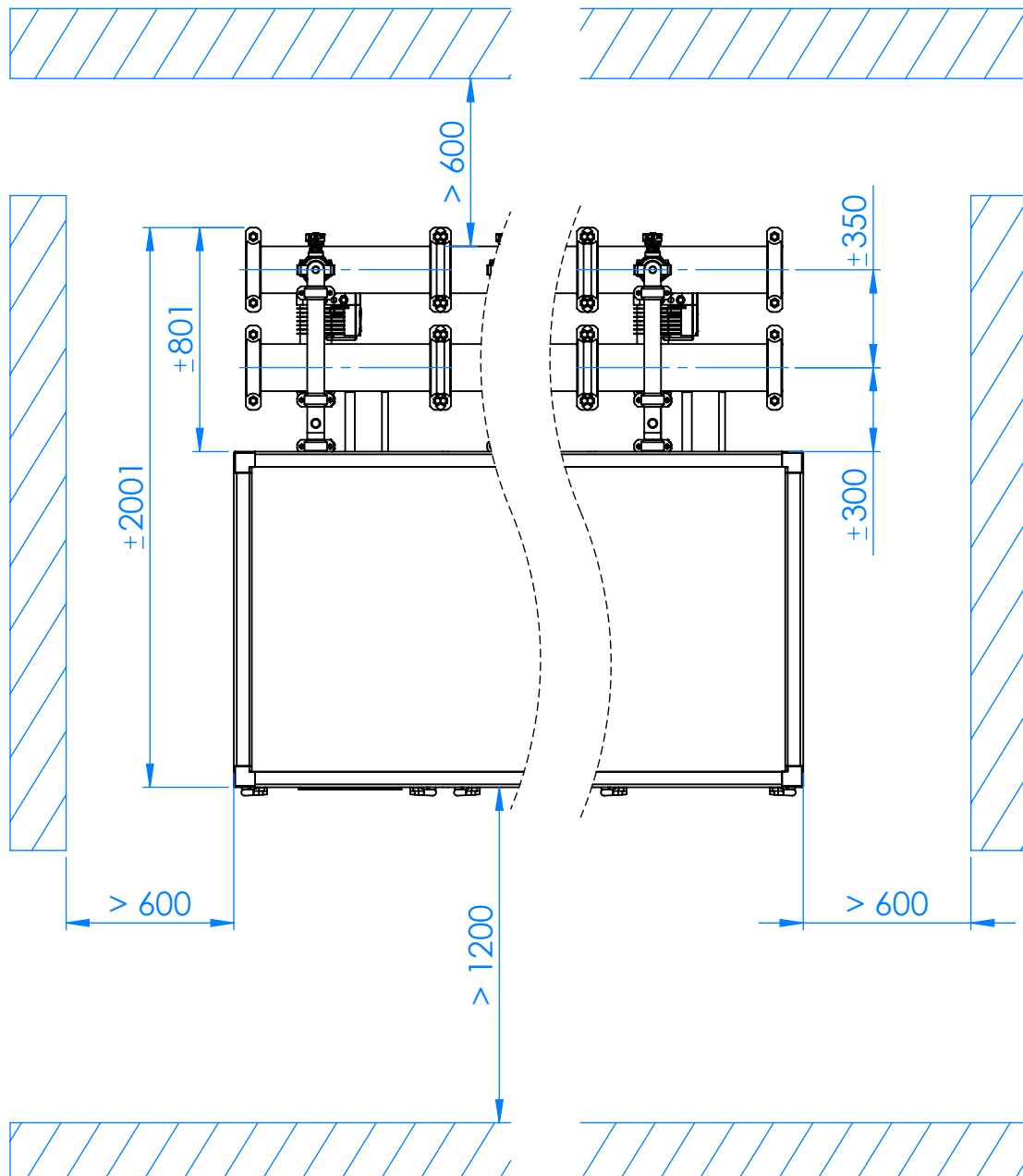

WAMAK AW 300 EVI HeavyDuty 2L3 - Split Einheit Variante: VOV900X2-FRAME

Anzahl von Einheiten

3



Gehäuse Bezeichnung: VOV900X2-FRAME			Verdampfer	
Artikel	WAVV2X90		Bauart	Cu-coil /Al-fin "
Grundlegende Abmessungen	Hohe [mm]	1400	Anschlussdimension	6 x (7/8" - 1.3/8") "
	Breite [mm]	1500	Wärmeträger	Luft
	Länge [mm]	2300	Volumenstrom - Luft [m3/h]	15073 ~ 90440
Gewicht [kg]	430		Interne Druckdifferenz - Luft [kPa]	6 x 0.061
Gehäuse Farbe	Edelstahl		Temperaturdifferenz - Luft	7 K
Gehäuse IP Klasse	IP44		Expansionsventil	EEV
Ventilator	800 mm			
Anzahl von Ventilatoren	2		Ventilator Installation	Vertikalachse
Motor von Ventilator, Typ	EC		Ventilator Bauart	Axial
Ventilator Strom Nominal [A]	1.35		Ventilator Einspeisung [V/Hz]	3~ 400/50
Minimale Leistungsaufnahme [Watt]	81		Maximale Leistungsaufnahme [Watt]	802

Schallleistungspegel L_w

77.9 dB(A)

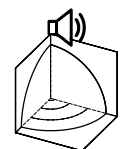
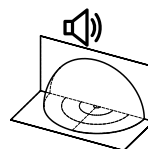
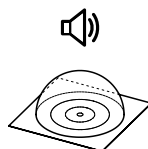

Entfernung [m]	1				5				10				15			
	1	5	10	15	1	5	10	15	1	5	10	15	1	5	10	15
Schalldruckpegel L _p [dB(A)]	72.9	58.9	52.9	49.4	75.9	61.9	55.9	52.4	69.9	55.9	49.9	46.4				

EC Fan 800mm

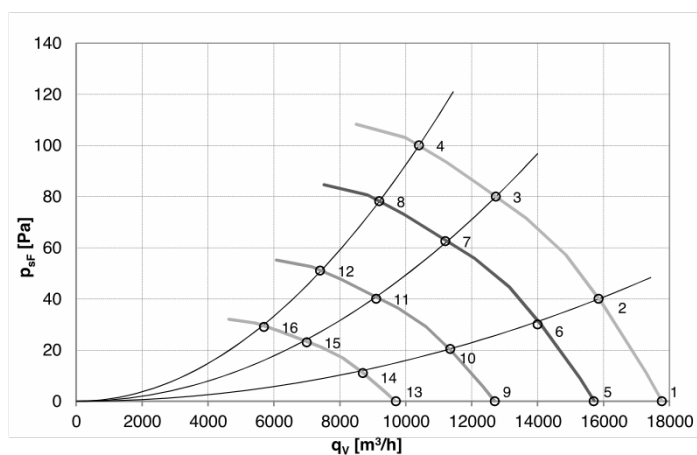

	U [V]	f [Hz]	n [RPM]	q _v [m³/h]	P _{sF} [Pa]	P _e [W]	I [A]	L _{WA out} [dB (A)]	T _{a max} [°C]
1	400	50	735	17770	0	503	0,85	70	60
2	400	50	735	15850	40	612	1,02	66	60
3	400	50	735	12730	80	735	1,18	65	60
4	400	50	735	10400	100	802	1,36	68	60
5	400	50	650	15700	0	348	0,68	67	60
6	400	50	650	14000	30	421	0,80	63	60
7	400	50	650	11200	63	510	0,92	62	60
8	400	50	650	9200	78	554	0,93	65	60
9	400	50	525	12700	0	183	0,38	63	60
10	400	50	525	11350	20	225	0,35	59	60
11	400	50	525	9100	40	265	0,53	58	60
12	400	50	525	7400	51	292	0,57	61	60
13	400	50	400	9700	0	81	0,21	57	60
14	400	50	400	8700	11	97	0,24	53	60
15	400	50	400	7000	23	117	0,27	52	60
16	400	50	400	5700	29	128	0,28	55	60

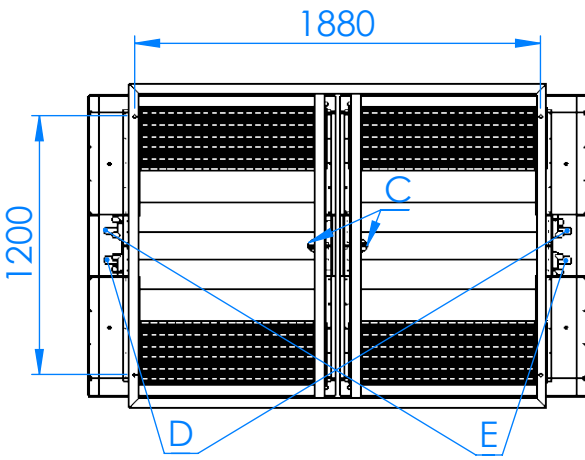
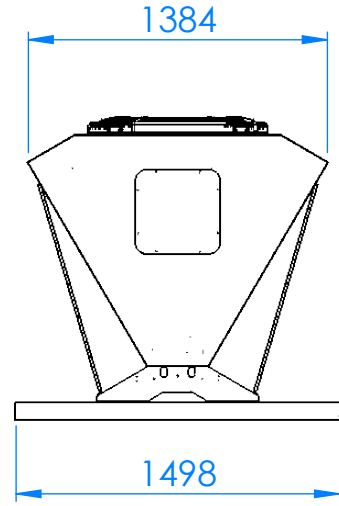
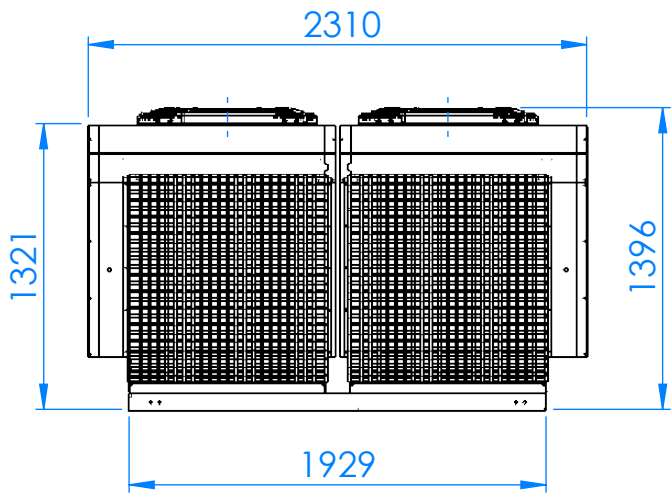

D - FRIGO GAS
E - FRIGO LIQUID
C - CONDENS

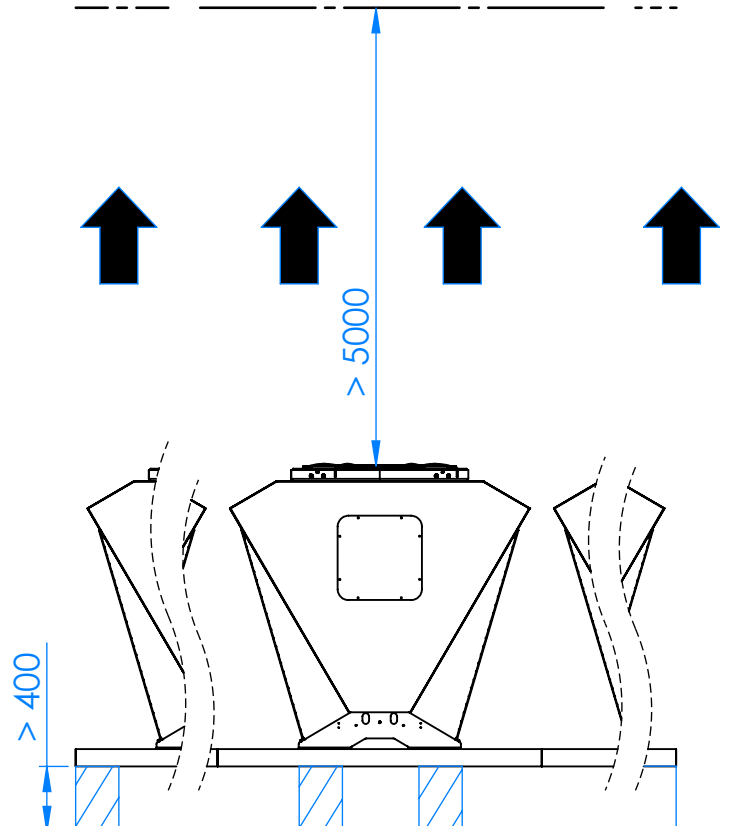
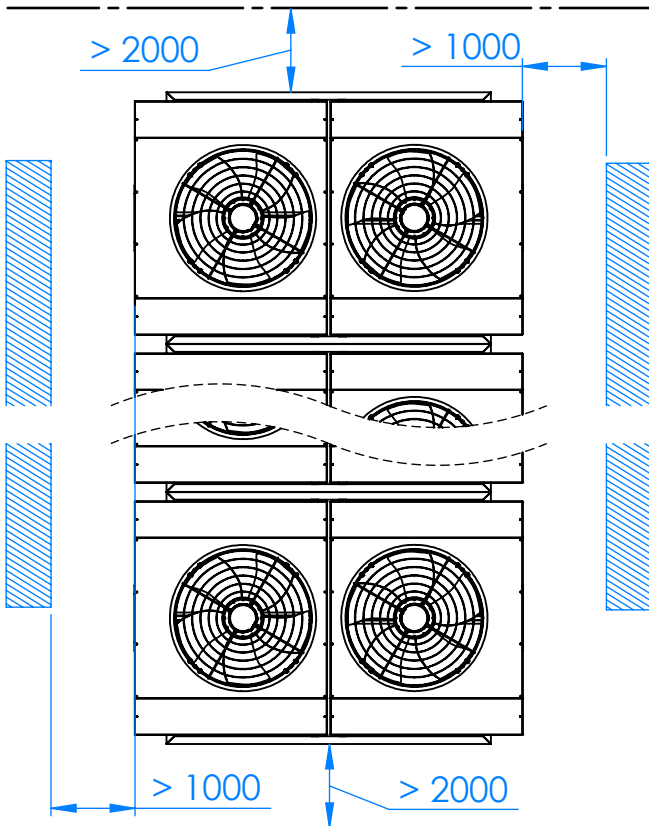
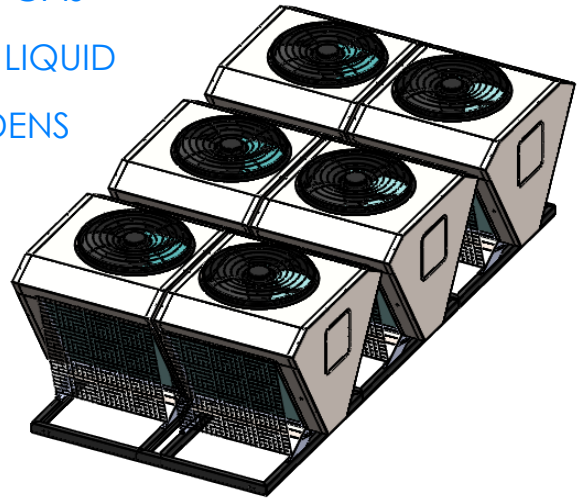

WAMAK AW 300 EVI HeavyDuty 2L3 - Split Einheit Variante: VOII-1200-2LOW

Anzahl von Einheiten

6

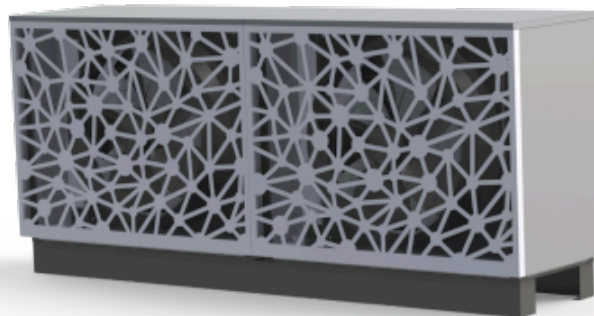

Gehäuse Bezeichnung: VOII-1200-2LOW			Verdampfer	
Artikel	WAVII12L		Bauart	Cu-coil /Al-fin "
Grundlegende Abmessungen	Hohe [mm]	1240	Anschlussdimension	6 x (7/8" - 1.3/8") "
	Breite [mm]	2850	Wärmeträger	Luft
	Länge [mm]	710	Volumenstrom - Luft [m3/h]	15073 ~ 90440
Gewicht [kg]	300		Interne Druckdifferenz - Luft [kPa]	6 x 0.061
Gehäuse Farbe	Grau		Temperaturdifferenz - Luft	7 K
Gehäuse IP Klasse	IP44		Expansionsventil	EEV
Ventilator	800 mm			
Anzahl von Ventilatoren	2		Ventilator Installation	Horizontalachse
Motor von Ventilator, Typ	EC		Ventilator Bauart	Axial
Ventilator Strom Nominal [A]	1.35		Ventilator Einspeisung [V/Hz]	3~ 400/50
Minimale Leistungsaufnahme [Watt]	81		Maximale Leistungsaufnahme [Watt]	802

Schallleistungspegel L_w

74.6 dB(A)

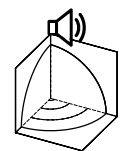
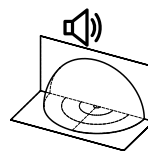
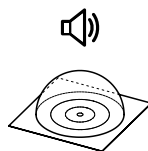

Entfernung [m]	1				5				10				15			
	1	5	10	15	1	5	10	15	1	5	10	15	1	5	10	15
Schalldruckpegel L _p [dB(A)]	69.6	55.6	49.6	46.1	72.6	58.6	52.6	49.1	66.6	52.6	46.6	43.1				

EC Fan 800mm

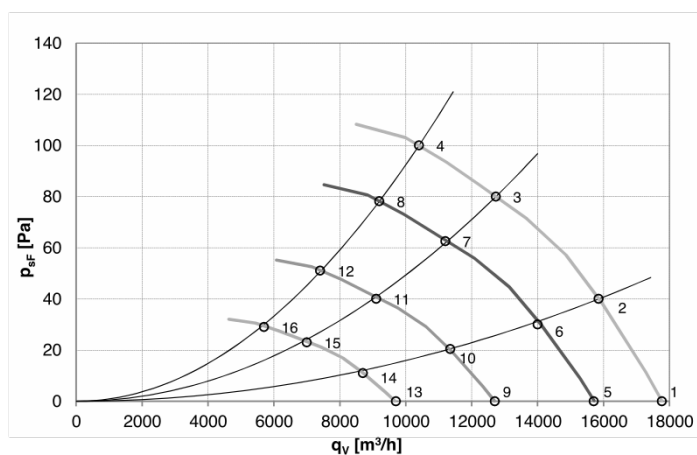

	U	f	n	q _v	P _{sF}	P _e	I	L _{WA out}	T _{a max}
	[V]	[Hz]	[RPM]	[m³/h]	[Pa]	[W]	[A]	[dB (A)]	[°C]
1	400	50	735	17770	0	503	0,85	70	60
2	400	50	735	15850	40	612	1,02	66	60
3	400	50	735	12730	80	735	1,18	65	60
4	400	50	735	10400	100	802	1,36	68	60
5	400	50	650	15700	0	348	0,68	67	60
6	400	50	650	14000	30	421	0,80	63	60
7	400	50	650	11200	63	510	0,92	62	60
8	400	50	650	9200	78	554	0,93	65	60
9	400	50	525	12700	0	183	0,38	63	60
10	400	50	525	11350	20	225	0,35	59	60
11	400	50	525	9100	40	265	0,53	58	60
12	400	50	525	7400	51	292	0,57	61	60
13	400	50	400	9700	0	81	0,21	57	60
14	400	50	400	8700	11	97	0,24	53	60
15	400	50	400	7000	23	117	0,27	52	60
16	400	50	400	5700	29	128	0,28	55	60

WAMAK AW 300 EVI HeavyDuty 2L3

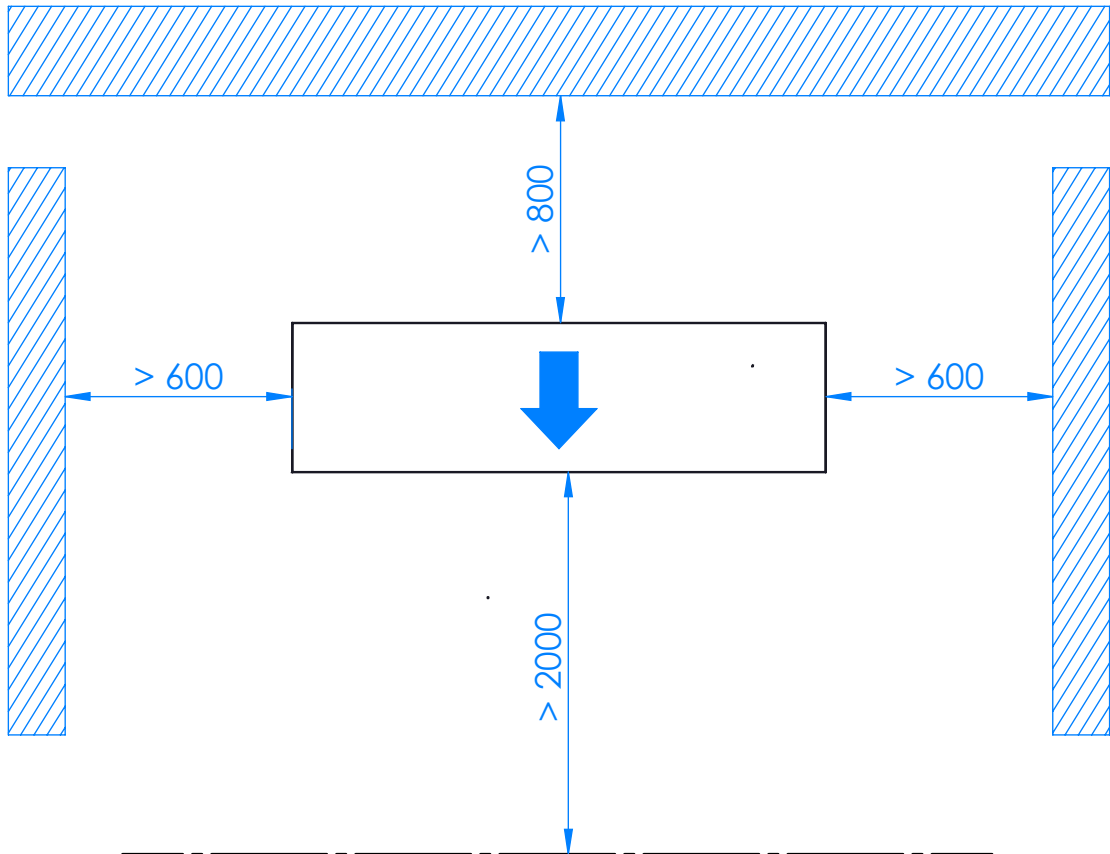
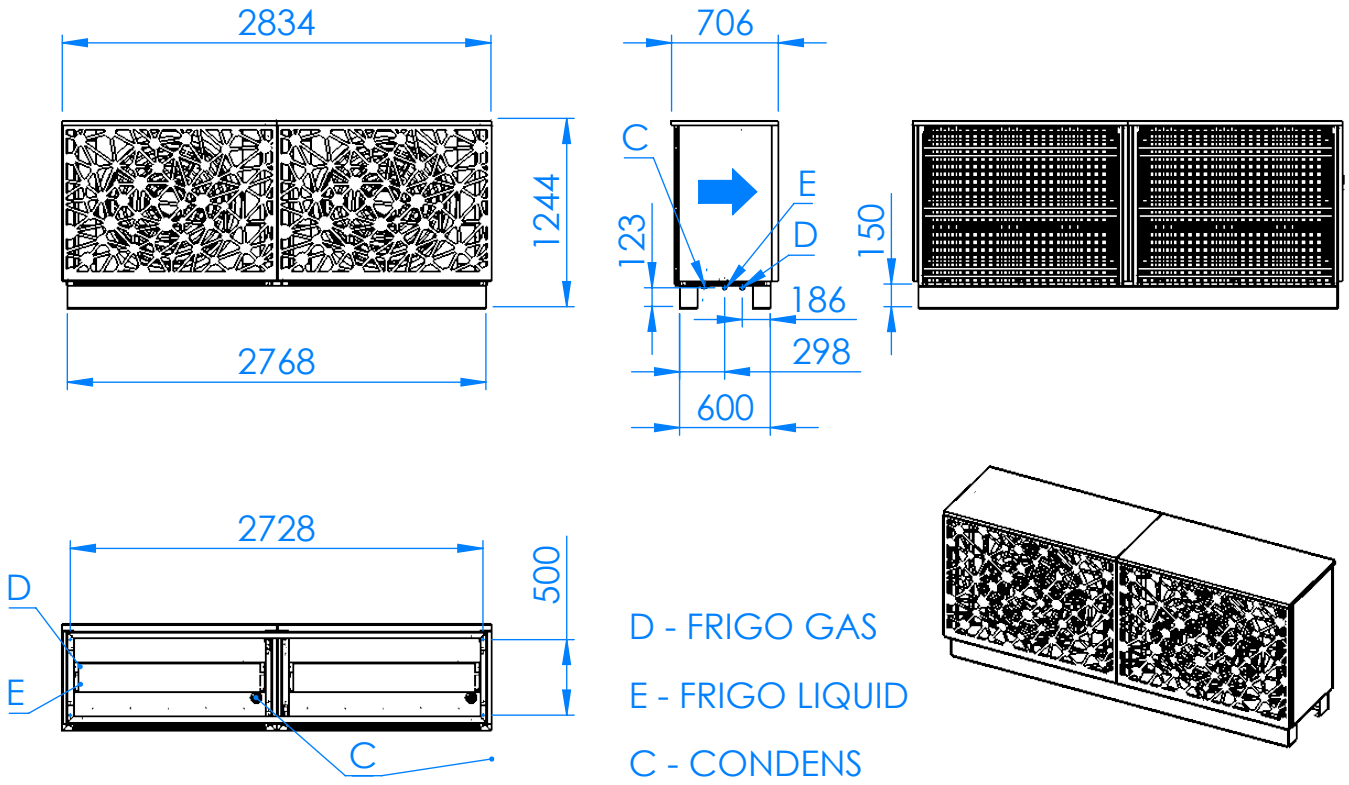

WAMAK AW 300 EVI HeavyDuty 2L3 - Split Einheit Variante: VOII-1200-2HIGH

Anzahl von Einheiten

6

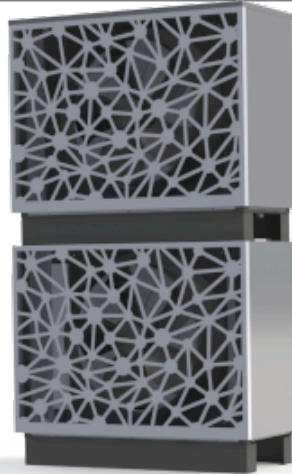

Gehäuse Bezeichnung: VOII-1200-2HIGH		Verdampfer		
Artikel	WAVII12H	Bauart	Cu-coil / Al-fin "	
Grundlegende Abmessungen	Hohe [mm]	2450	Anschlussdimension	6 x (7/8" - 1.3/8") "
	Breite [mm]	1420	Wärmeträger	Luft
	Länge [mm]	710	Volumenstrom - Luft [m3/h]	15073 ~ 90440
Gewicht [kg]	300	Interne Druckdifferenz - Luft [kPa]	6 x 0.061	
Gehäuse Farbe	Grau	Temperaturdifferenz - Luft	7 K	
Gehäuse IP Klasse	IP44	Expansionsventil	EEV	
Ventilator	800 mm			
Anzahl von Ventilatoren	2	Ventilator Installation	Horizontalachse	
Motor von Ventilator, Typ	EC	Ventilator Bauart	Axial	
Ventilator Strom Nominal [A]	1.35	Ventilator Einspeisung [V/Hz]	3~ 400/50	
Minimale Leistungsaufnahme [Watt]	81	Maximale Leistungsaufnahme [Watt]	802	

Schallleistungspegel L_w

74.6 dB(A)

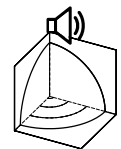
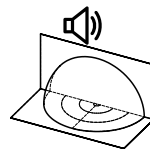
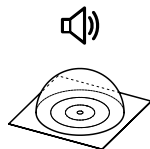

Entfernung [m]	1				5				10				15			
	1	5	10	15	1	5	10	15	1	5	10	15	1	5	10	15
Schalldruckpegel L _p [dB(A)]	69.6	55.6	49.6	46.1	72.6	58.6	52.6	49.1	66.6	52.6	46.6	43.1				

EC Fan 800mm

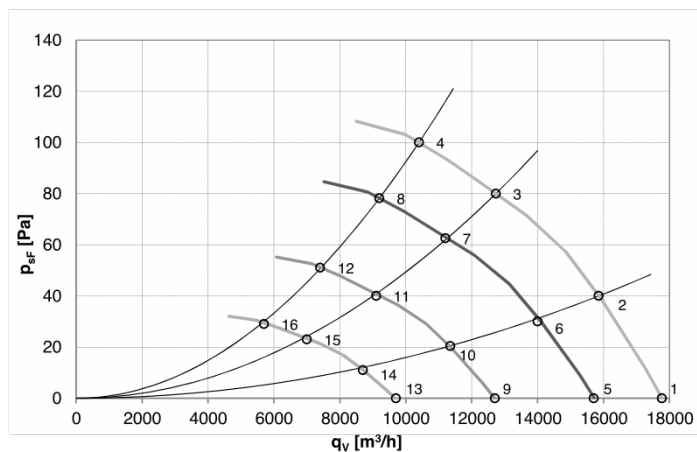

	U	f	n	q _v	P _{sF}	P _e	I	L _{WA out}	T _{a max}
	[V]	[Hz]	[RPM]	[m³/h]	[Pa]	[W]	[A]	[dB (A)]	[°C]
1	400	50	735	17770	0	503	0,85	70	60
2	400	50	735	15850	40	612	1,02	66	60
3	400	50	735	12730	80	735	1,18	65	60
4	400	50	735	10400	100	802	1,36	68	60
5	400	50	650	15700	0	348	0,68	67	60
6	400	50	650	14000	30	421	0,80	63	60
7	400	50	650	11200	63	510	0,92	62	60
8	400	50	650	9200	78	554	0,93	65	60
9	400	50	525	12700	0	183	0,38	63	60
10	400	50	525	11350	20	225	0,35	59	60
11	400	50	525	9100	40	265	0,53	58	60
12	400	50	525	7400	51	292	0,57	61	60
13	400	50	400	9700	0	81	0,21	57	60
14	400	50	400	8700	11	97	0,24	53	60
15	400	50	400	7000	23	117	0,27	52	60
16	400	50	400	5700	29	128	0,28	55	60

WAMAK AW 300 EVI HeavyDuty 2L3

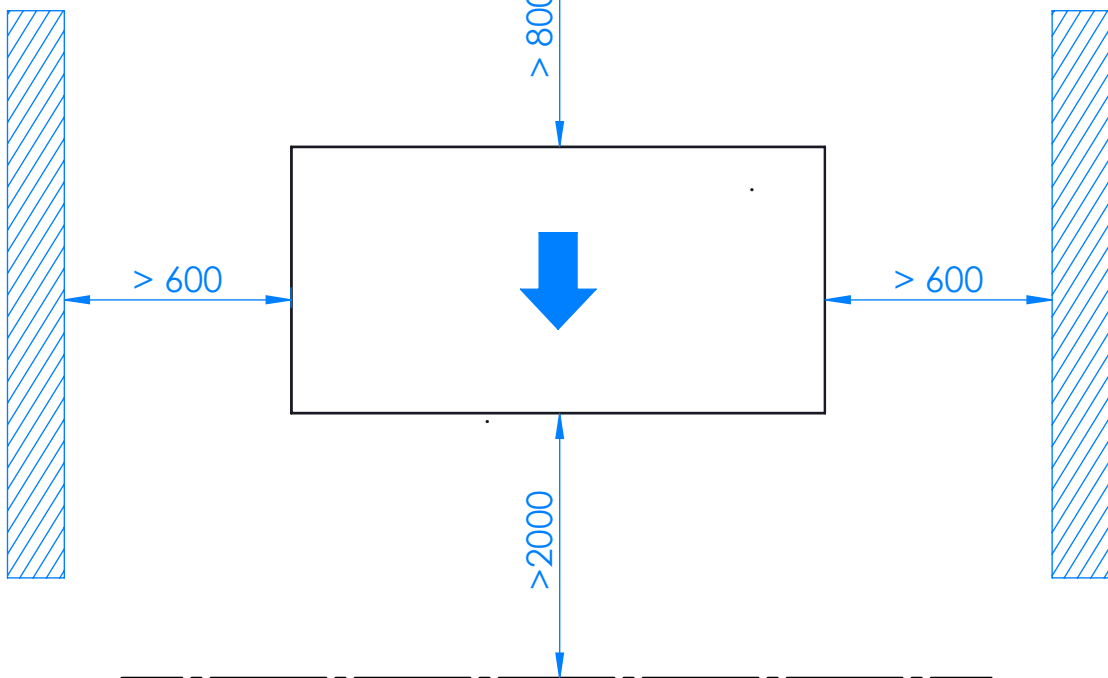
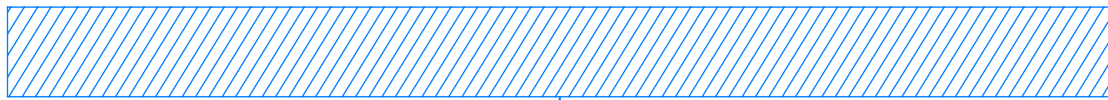
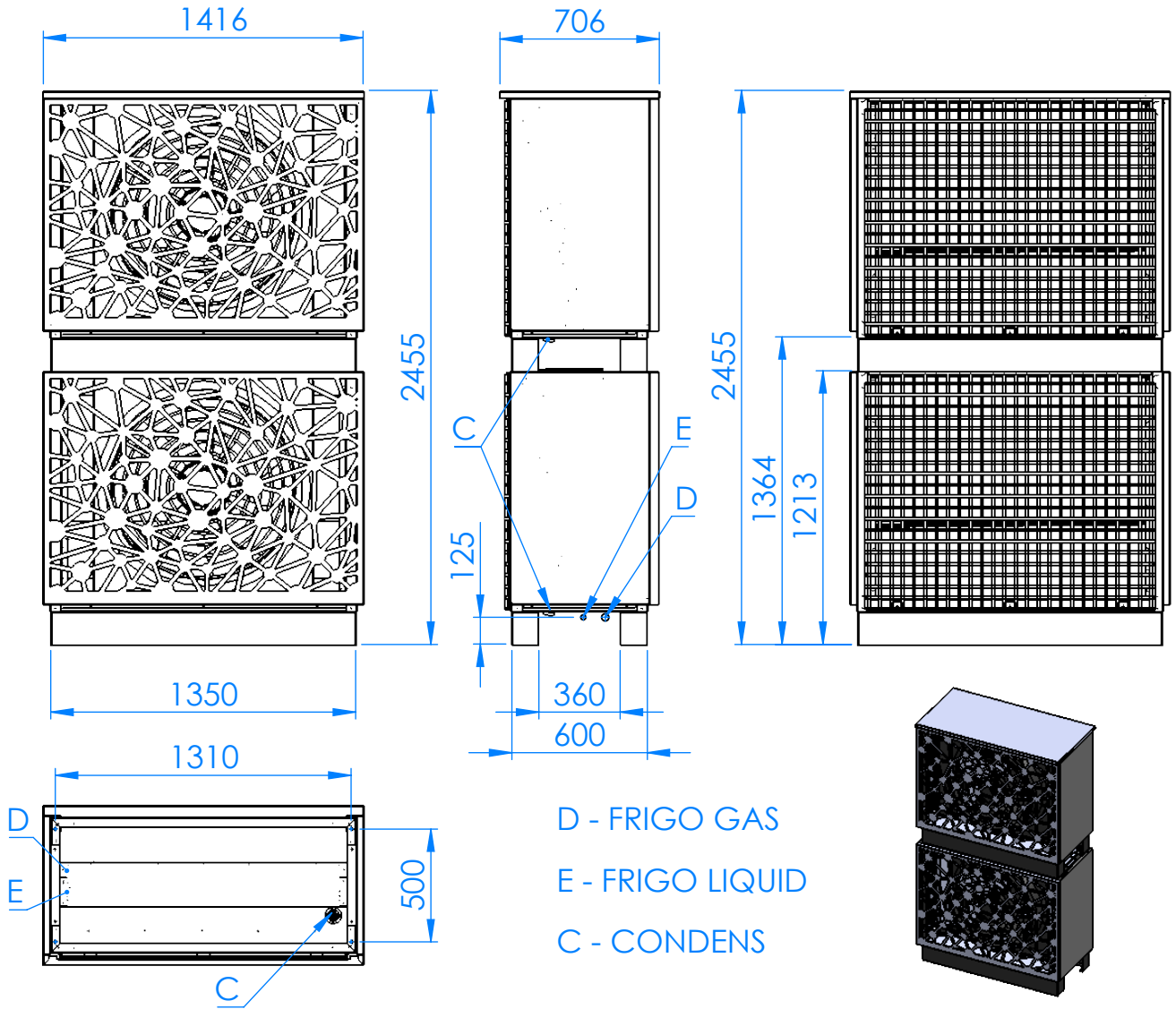

WAMAK AW 300 EVI HeavyDuty 2L3 - Split Einheit Variante: VOII-1200-2LOW-DUCT

Anzahl von Einheiten

6

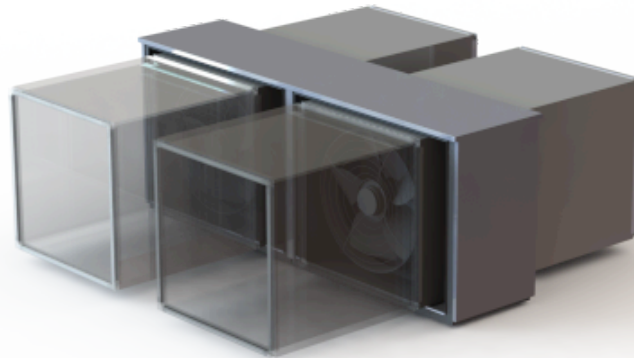

Gehäuse Bezeichnung: VOII-1200-2LOW-DUCT		Verdampfer		
Artikel	WAVID12L	Bauart	Cu-coil /Al-fin "	
Grundlegende Abmessungen	Hohe [mm]	1240	Anschlussdimension	6 x (7/8" - 1.3/8") "
	Breite [mm]	2850	Wärmeträger	Luft
	Länge [mm]	710	Volumenstrom - Luft [m3/h]	15073 ~ 90440
Gewicht [kg]	300	Interne Druckdifferenz - Luft [kPa]	6 x 0.061	
Gehäuse Farbe	Grau	Temperaturdifferenz - Luft	7 K	
Gehäuse IP Klasse	IP44	Expansionsventil	EEV	
Ventilator	800 mm			
Anzahl von Ventilatoren	2	Ventilator Installation	Horizontalachse	
Motor von Ventilator, Typ	EC	Ventilator Bauart	Axial	
Ventilator Strom Nominal [A]	1.35	Ventilator Einspeisung [V/Hz]	3~ 400/50	
Minimale Leistungsaufnahme [Watt]	81	Maximale Leistungsaufnahme [Watt]	802	

Schallleistungspegel L_w

74.6 dB(A)

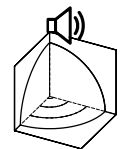
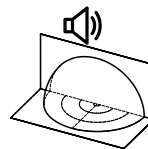
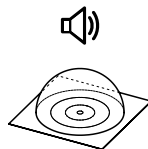

Entfernung [m]	1				5				10				15			
	1	5	10	15	1	5	10	15	1	5	10	15	1	5	10	15
Schalldruckpegel L _p [dB(A)]	69.6	55.6	49.6	46.1	72.6	58.6	52.6	49.1	66.6	52.6	46.6	43.1				

EC Fan 800mm

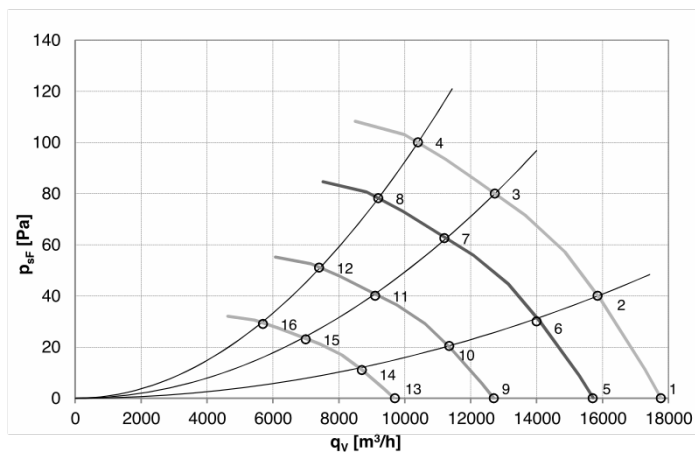

	U [V]	f [Hz]	n [RPM]	q _v [m³/h]	P _{sF} [Pa]	P _e [W]	I [A]	L _{WA out} [dB (A)]	T _{a max} [°C]
1	400	50	735	17770	0	503	0,85	70	60
2	400	50	735	15850	40	612	1,02	66	60
3	400	50	735	12730	80	735	1,18	65	60
4	400	50	735	10400	100	802	1,36	68	60
5	400	50	650	15700	0	348	0,68	67	60
6	400	50	650	14000	30	421	0,80	63	60
7	400	50	650	11200	63	510	0,92	62	60
8	400	50	650	9200	78	554	0,93	65	60
9	400	50	525	12700	0	183	0,38	63	60
10	400	50	525	11350	20	225	0,35	59	60
11	400	50	525	9100	40	265	0,53	58	60
12	400	50	525	7400	51	292	0,57	61	60
13	400	50	400	9700	0	81	0,21	57	60
14	400	50	400	8700	11	97	0,24	53	60
15	400	50	400	7000	23	117	0,27	52	60
16	400	50	400	5700	29	128	0,28	55	60

WAMAK AW 300 EVI HeavyDuty 2L3 - Split Einheit Variante: VOII-1200-2HIGH-DUCT

Anzahl von Einheiten

6

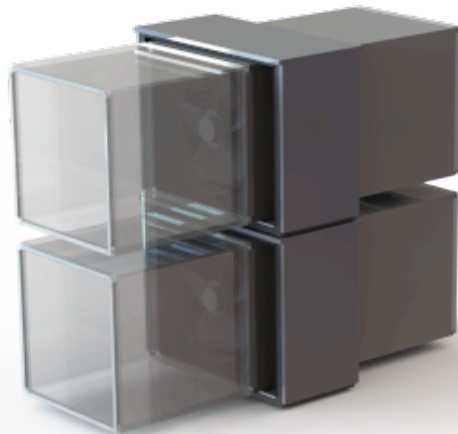

Gehäuse Bezeichnung: VOII-1200-2HIGH-DUCT		Verdampfer		
Artikel	WAVID12H	Bauart	Cu-coil /Al-fin "	
Grundlegende Abmessungen	Hohe [mm]	2450	Anschlussdimension	6 x (7/8" - 1.3/8") "
	Breite [mm]	1420	Wärmeträger	Luft
	Länge [mm]	710	Volumenstrom - Luft [m3/h]	15073 ~ 90440
Gewicht [kg]	300	Interne Druckdifferenz - Luft [kPa]	6 x 0.061	
Gehäuse Farbe	Grau	Temperaturdifferenz - Luft	7 K	
Gehäuse IP Klasse	IP44	Expansionsventil	EEV	
Ventilator	800 mm			
Anzahl von Ventilatoren	2	Ventilator Installation	Horizontalachse	
Motor von Ventilator, Typ	EC	Ventilator Bauart	Axial	
Ventilator Strom Nominal [A]	1.35	Ventilator Einspeisung [V/Hz]	3~ 400/50	
Minimale Leistungsaufnahme [Watt]	81	Maximale Leistungsaufnahme [Watt]	802	

Schallleistungspegel L_w

74.6 dB(A)

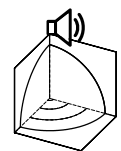
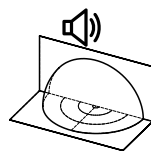
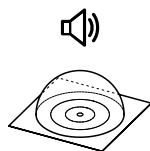

Entfernung [m]	1				5				10				15			
	1	5	10	15	1	5	10	15	1	5	10	15	1	5	10	15
Schalldruckpegel L _p [dB(A)]	69.6	55.6	49.6	46.1	72.6	58.6	52.6	49.1	66.6	52.6	46.6	43.1				

EC Fan 800mm

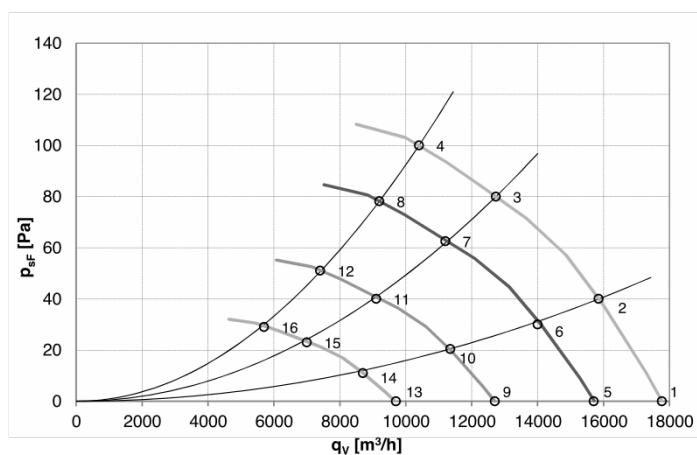

	U	f	n	q _v	P _{sF}	P _e	I	L _{WA out}	T _{a max}
	[V]	[Hz]	[RPM]	[m³/h]	[Pa]	[W]	[A]	[dB (A)]	[°C]
1	400	50	735	17770	0	503	0,85	70	60
2	400	50	735	15850	40	612	1,02	66	60
3	400	50	735	12730	80	735	1,18	65	60
4	400	50	735	10400	100	802	1,36	68	60
5	400	50	650	15700	0	348	0,68	67	60
6	400	50	650	14000	30	421	0,80	63	60
7	400	50	650	11200	63	510	0,92	62	60
8	400	50	650	9200	78	554	0,93	65	60
9	400	50	525	12700	0	183	0,38	63	60
10	400	50	525	11350	20	225	0,35	59	60
11	400	50	525	9100	40	265	0,53	58	60
12	400	50	525	7400	51	292	0,57	61	60
13	400	50	400	9700	0	81	0,21	57	60
14	400	50	400	8700	11	97	0,24	53	60
15	400	50	400	7000	23	117	0,27	52	60
16	400	50	400	5700	29	128	0,28	55	60

WAMAK AW 300 EVI HeavyDuty 2L3

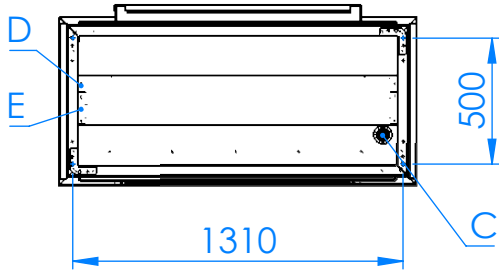
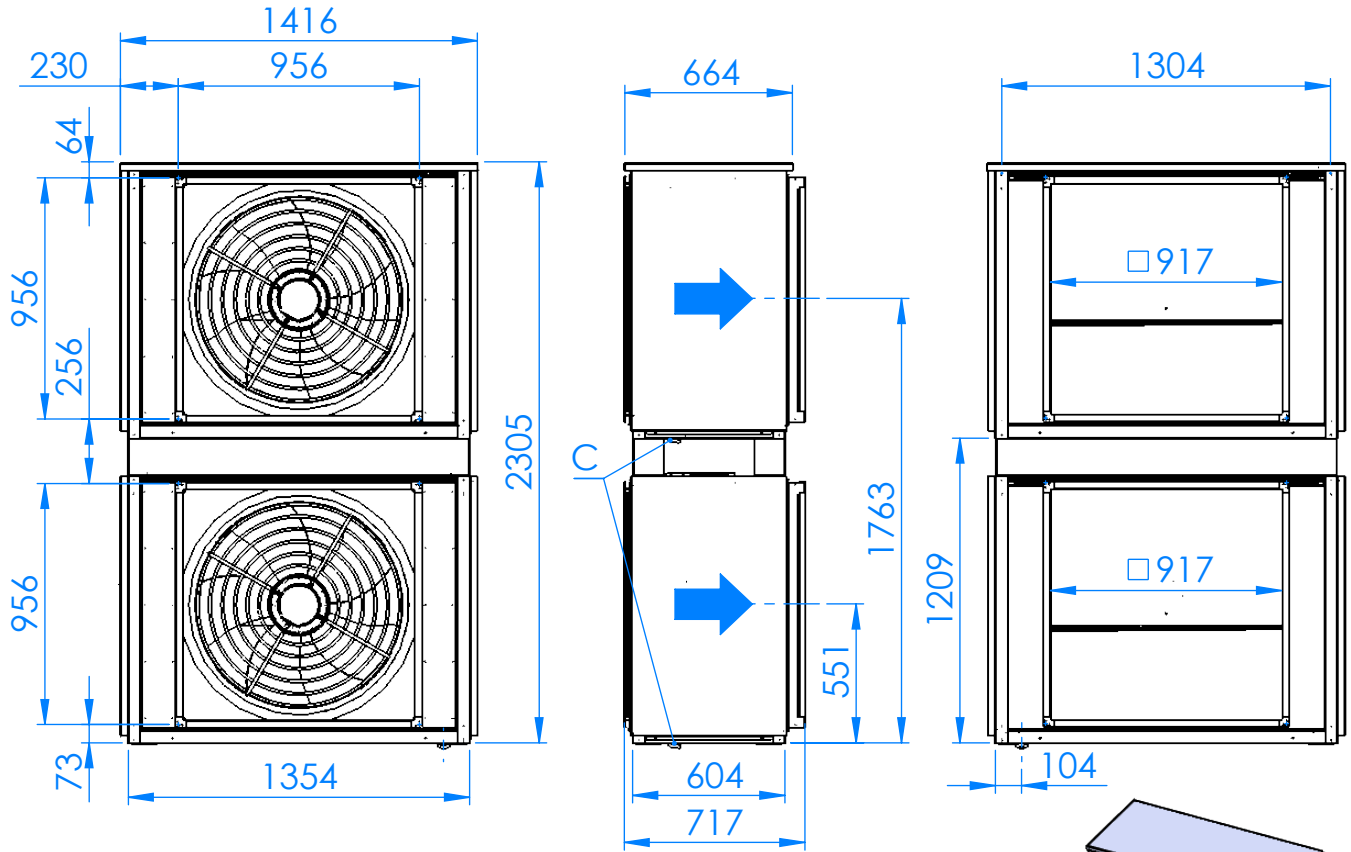

D - FRIGO GAS
 E - FRIGO LIQUID
 C - CONDENS

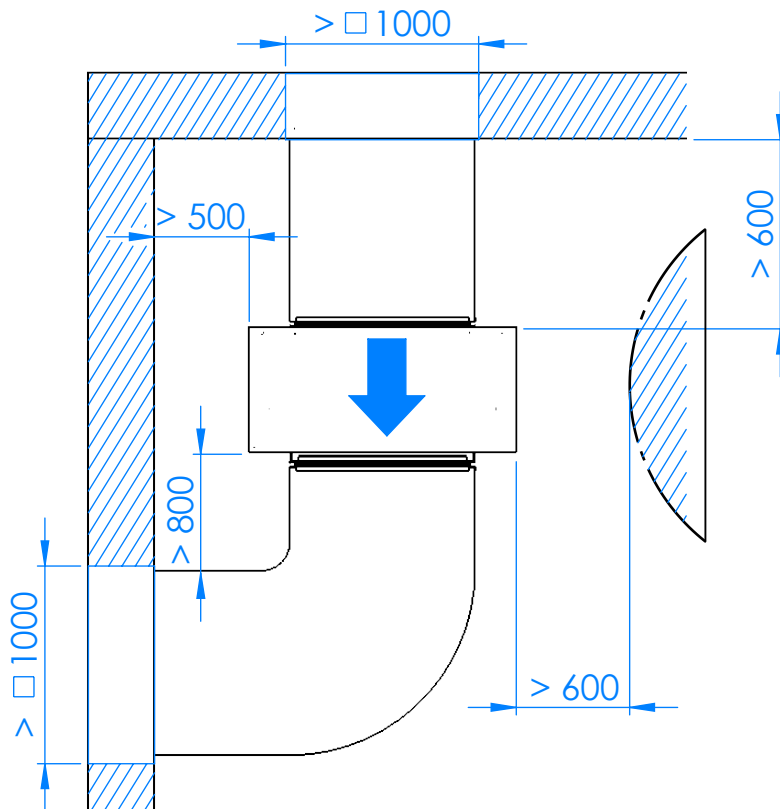
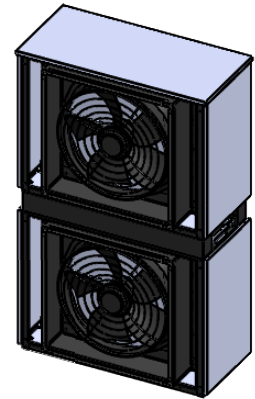

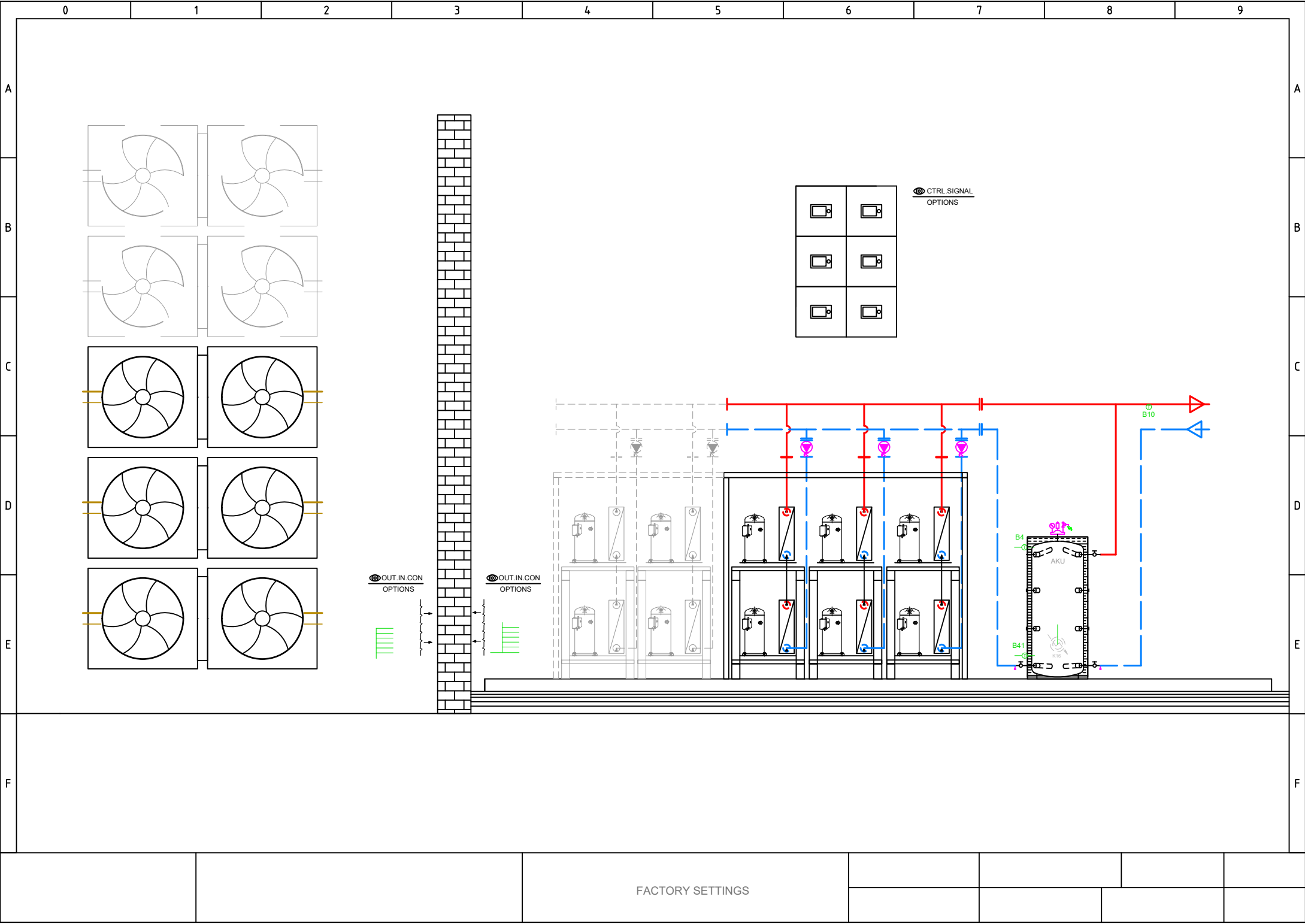

CTRL.SIGNAL
OPTIONS

OUT.IN.CON
OPTIONS

OUT.IN.CON
OPTIONS

B4
B41
AKU
K18

FACTORY SETTINGS



Netzanschluss 230V / 50 Hz

Erde

Nullleiter

E10 Hochdruckwächter E10

E11 Überlast Verdichter 1 E11

E14 Überlast Quelle E14

E24 Ström'wächter Verbrau E24

K82 Ventil EVI K82

K40 Ölsumpfheizung K40

L Faze 230V

K1 Verdichterstufe 1 K1

Y22 Prozessumkehrventil Y22

Q9 Kondensatorpumpe Q9

X10	1	L
X10	1	PE
X10	1	N
X11	1	EX1
X11	1	EX2
X11	1	EX3
X11	1	EX4
X12	1	QX1
X12	1	N
X12	1	QX2
X12	1	QX2i
X12	1	N
X12	1	FX3
X12	1	QX3
X15	1	QX4
X15	1	QX4i
X15	1	N
X15	1	QX5
X15	1	N
X15	1	ZX6
X15	1	N
X86	1	GX1
X86	1	H3
X86	1	M
X86	1	H1
X86	1	G+
X86	1	M
X86	1	BSB



Total: max 6A
1 x QX...: max 2A

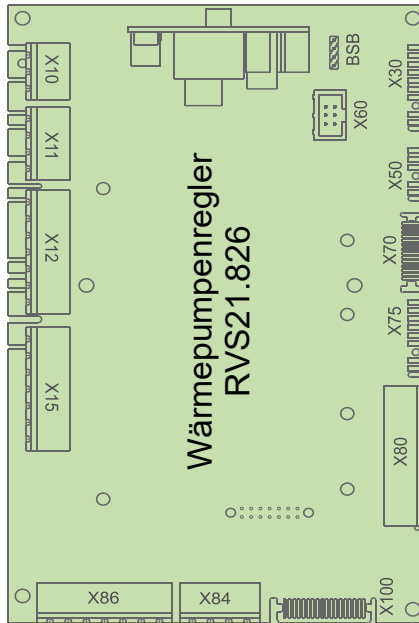

BSB
X30
X60
X50
X70

Anschluss Servicetool (OCI700)
Bediengerät (HMI) AVS37.xxx
Modbus-Clip-In OCI351.01
Erweiterungsmodul AVS75.xxx
LPB clip-in

D1
D2
D3
UX3
M
DI6
DI7
M

D1 Digi Ausgang 1 Heizen
D2 Digi Ausgang 2 Kühlung
D3 Digi Ausgang 3 WP Ein/Aus

DI6 Digi Eingang 6 Abtauen
DI7 Digi Eingang 7 Alarm

BX1
M
BX2
M
UX1
M
UX2
M

B91 Quelleneintrittfühler B91

B84 Quellenaust'fühler B92/B84

K19 Ventilator K19

0..10V Analogsignal

Q9 Kondensatorpumpe Q9

PWM Signal

BX3
M
BX4
M

B71 WP Rücklauffühler B71

B9 Aussentemperaturfühler B9

Netzanschluss 230V / 50 Hz

Erde

Nullleiter

K10 Alarmausgang K10

V81 EEV Verdampfer V81

X10	1	L
X10	1	PE
X10	1	N
X110	1	QX31
X110	1	QX32
X110	1	N
X110	1	QX33
X110	1	N
X110	1	ZX34
X110	1	N
X115	1	QX35
X115	1	QX35i
X115	1	N

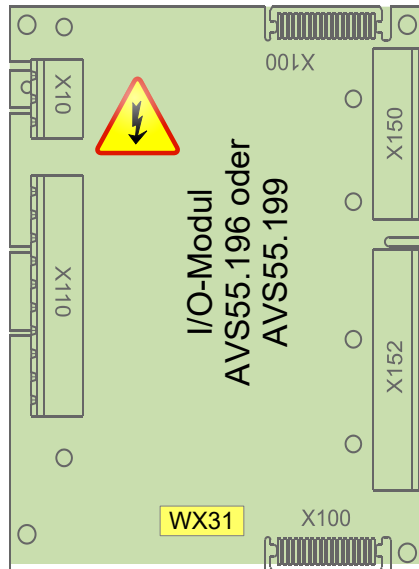

BSB
M
G+
H31
M
H32
GX1
H33
M
BX31
M
BX32
M
BX33
M
BX34
M

5V/12V für aktive Fühler
Durchflussmessung 10V

Niederdruck 0..10V

5V/12V für aktive Fühler

Hochdruck 0..10V

B21 WP Vorlauffühler B21

B81 Heissgasfühler B81

B85 Sauggasfühler B85

B83 Kältemittelfühler flüssig B83



- AVS75.390
- AVS75.391
- AVS75.370

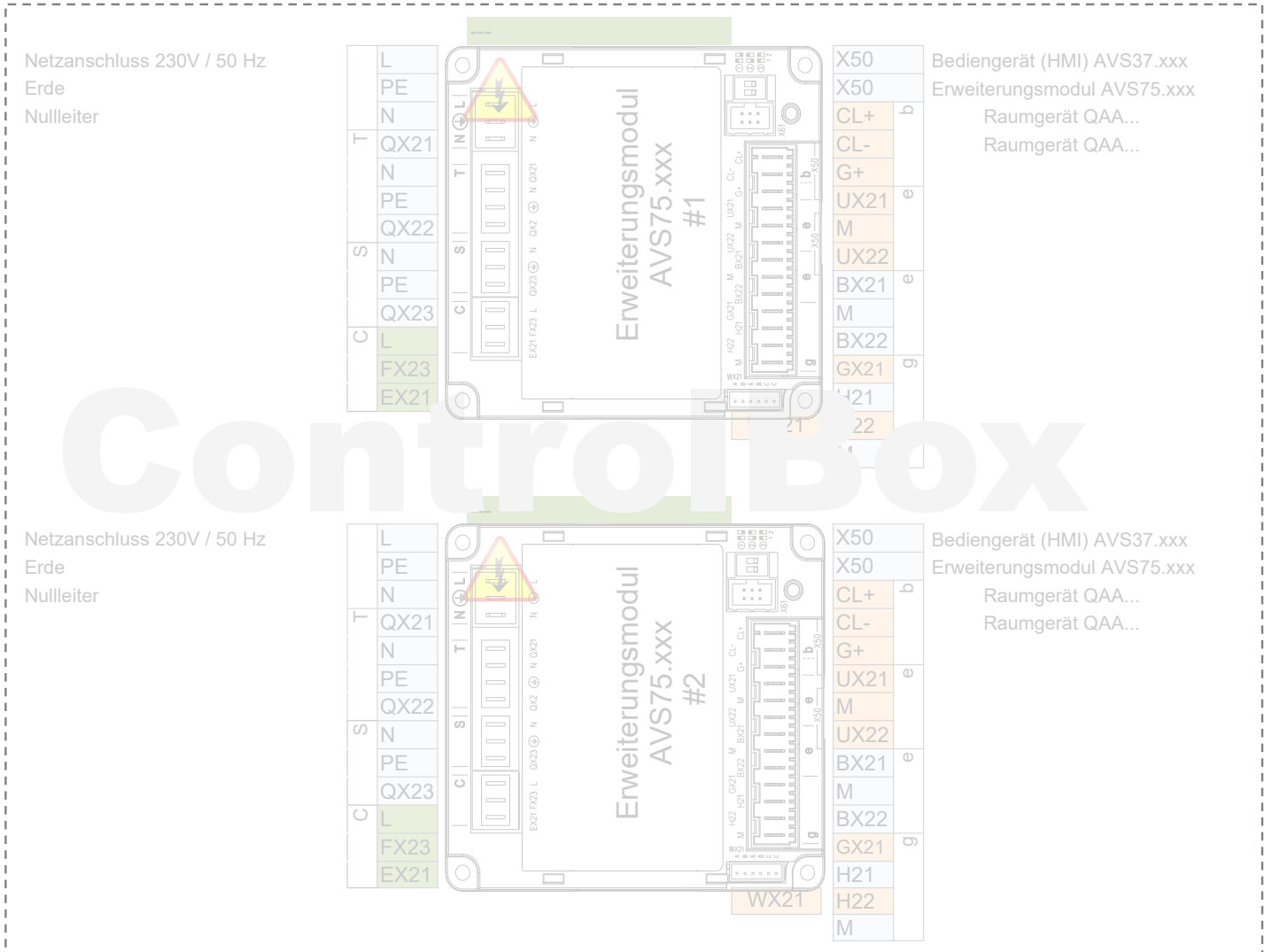

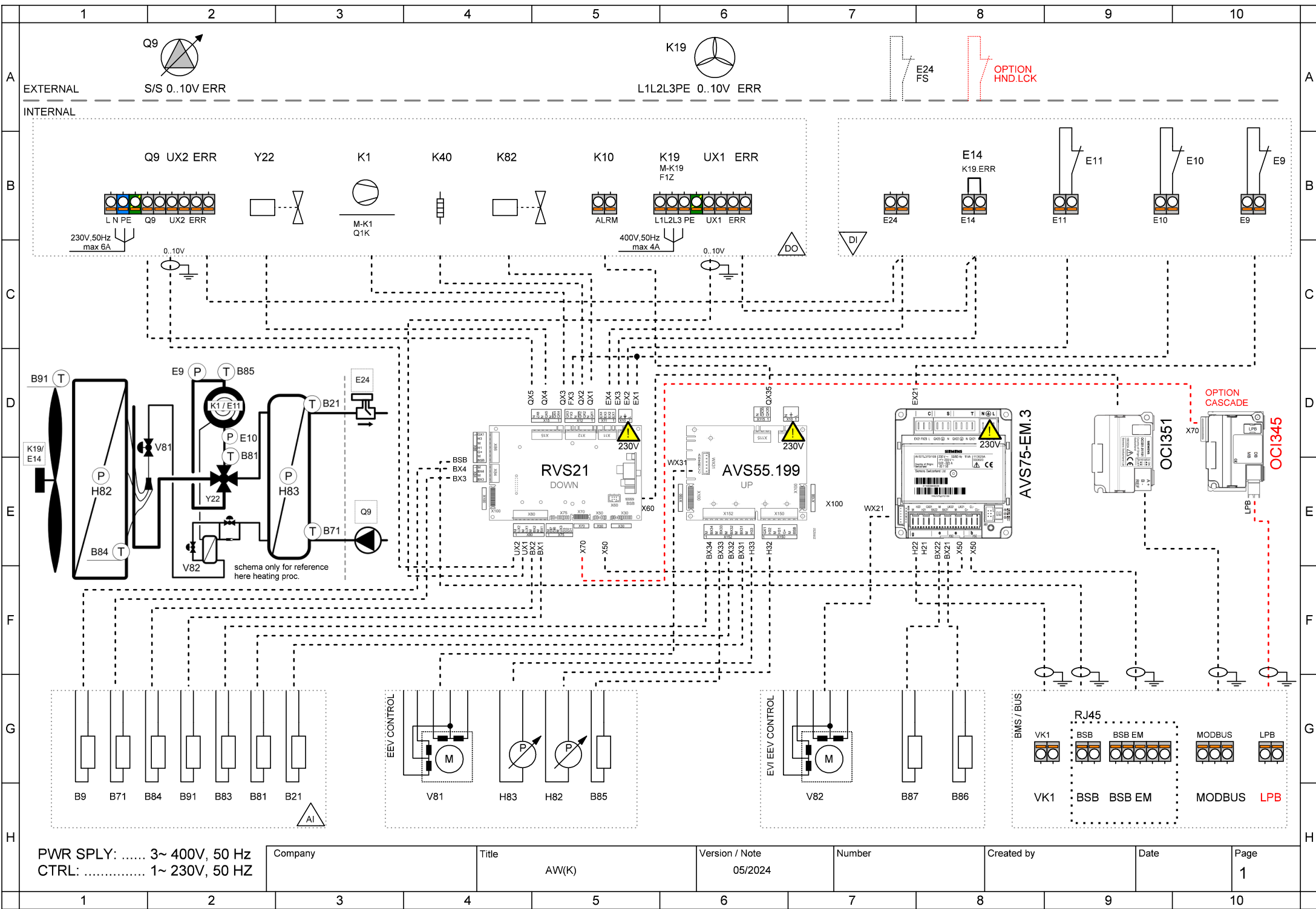

PWR SPLY: 3~ 400V, 50 Hz
 CTRL: 1~ 230V, 50 HZ

Company	Title	Version / Note	Number	Created by	Date	Page
	AW(K)	05/2024				1

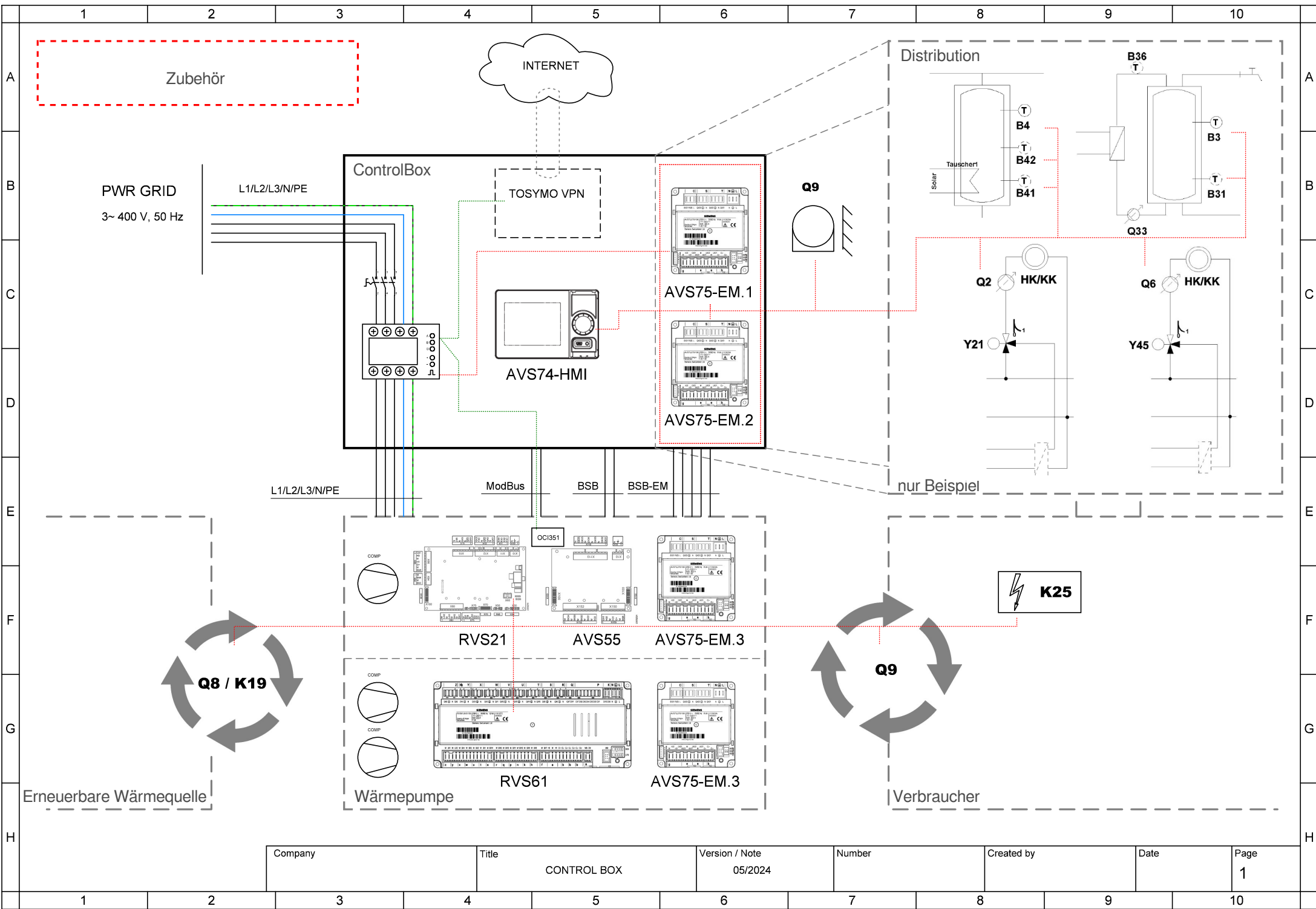

Company	Title	Version / Note	Number	Created by	Date	Page
	CONTROL BOX	05/2024				1

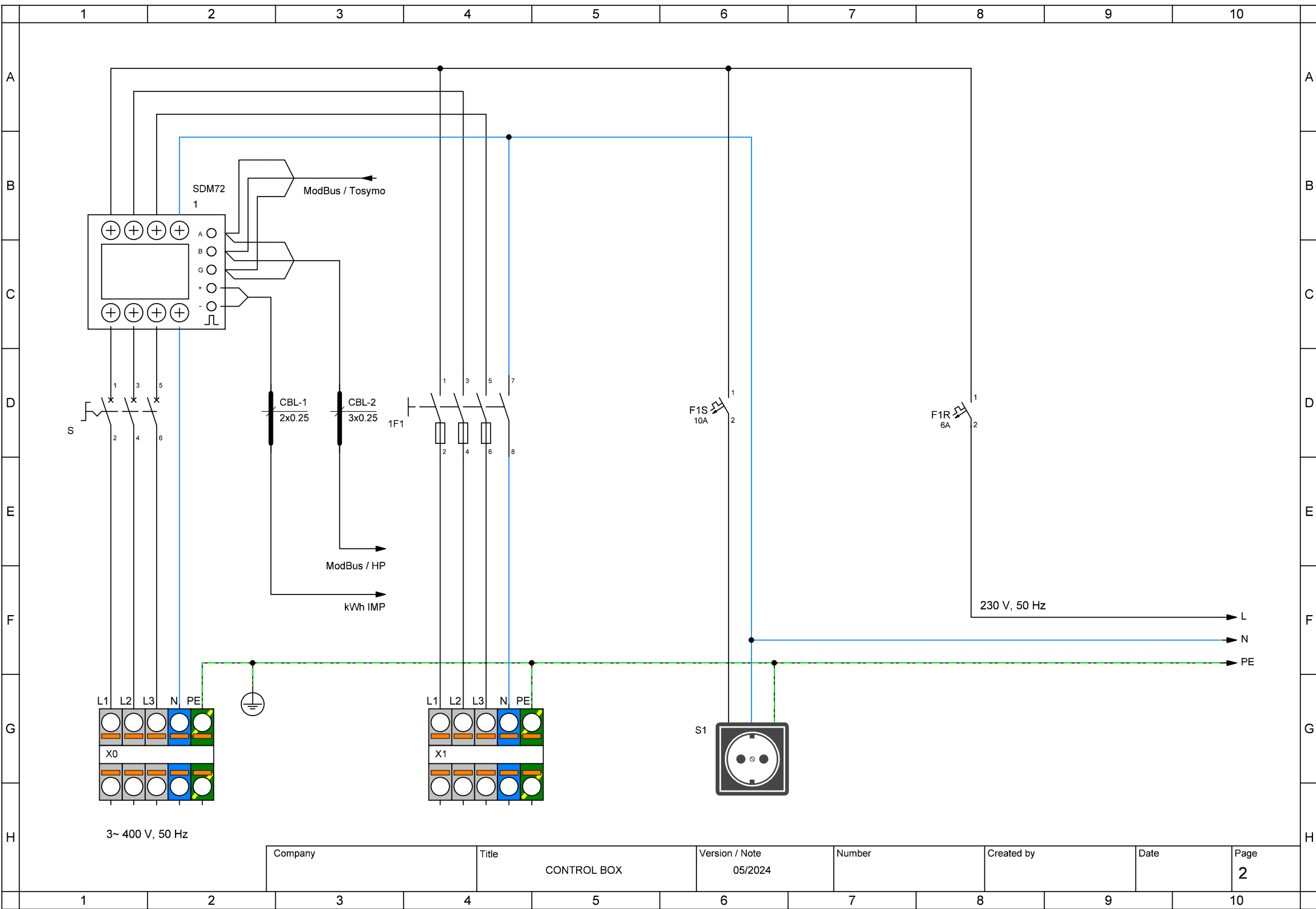

Company	Title	Version / Note	Number	Created by	Date	Page
	CONTROL BOX	05/2024				2

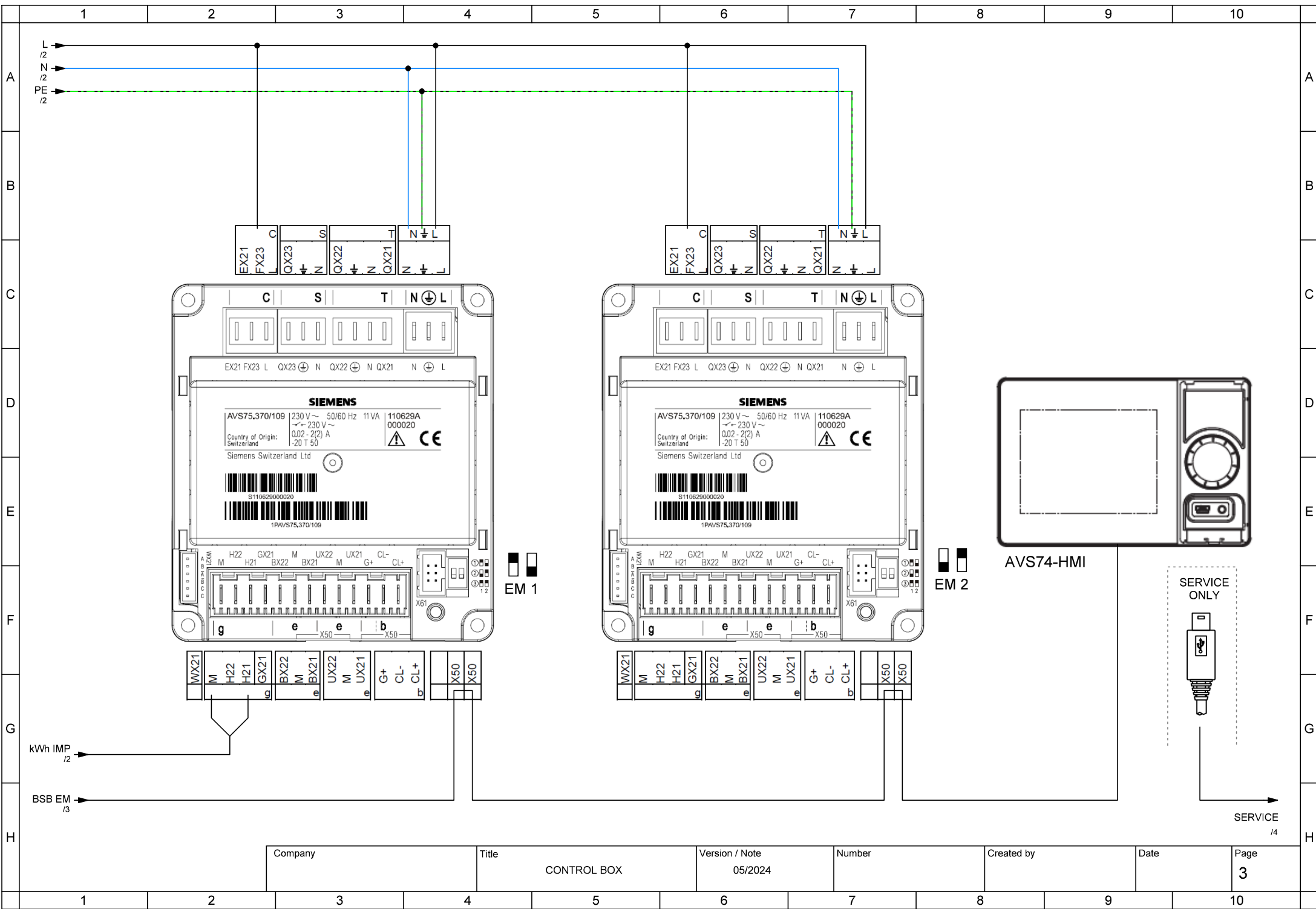

Company	Title	Version / Note	Number	Created by	Date	Page
	CONTROL BOX	05/2024				3



- AVS75.390
- AVS75.391
- AVS75.370

- AVS75.370**
 Netzanschluss 230V / 50 Hz
 Erde
 Nullleiter
Y1 Mischer Auf

Y2 Mischer Zu

Q2 Heizkreispumpe HK1 Q2

L Faze 230V
E61 Smart Grid E61

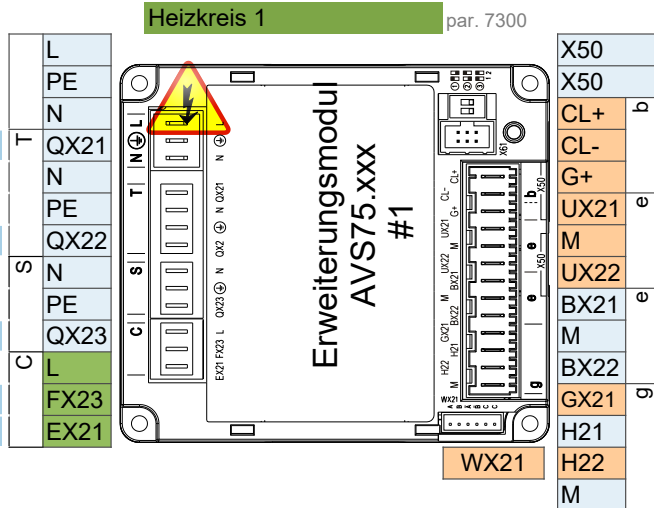

- Erweiterungsmodul AVS75.xxx
 Raumgerät QAA...
 Raumgerät QAA...

B1 Vorlauffühler 1

Impulszählung

- AVS75.370**
 Netzanschluss 230V / 50 Hz
 Erde
 Nullleiter
Q3 Trinkwasserstellglied Q3

K6 Elektroeinsatz TWW K6

Q6 Heizkreispumpe HK2 Q6

L Faze 230V
E62 Smart Grid E62

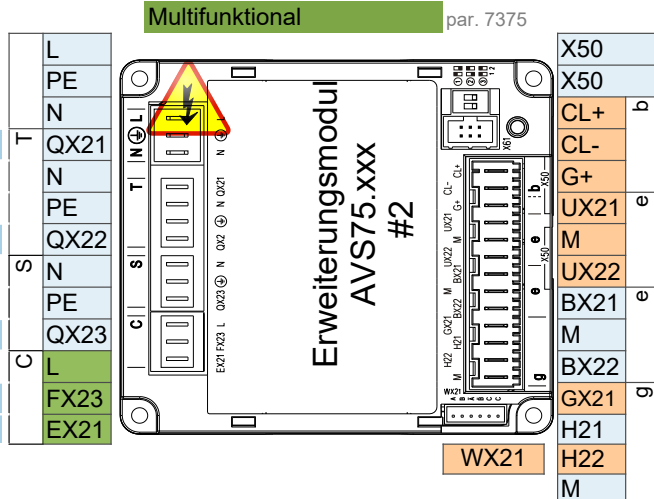

- Bediengerät (HMI) AVS37.xxx
 Erweiterungsmodul AVS75.xxx
 Raumgerät QAA...
 Raumgerät QAA...

B3 Trinkwasserfühler B3

B4 Pufferspeicherfühler B4

- Netzanschluss 230V / 50 Hz
 Erde
 Nullleiter

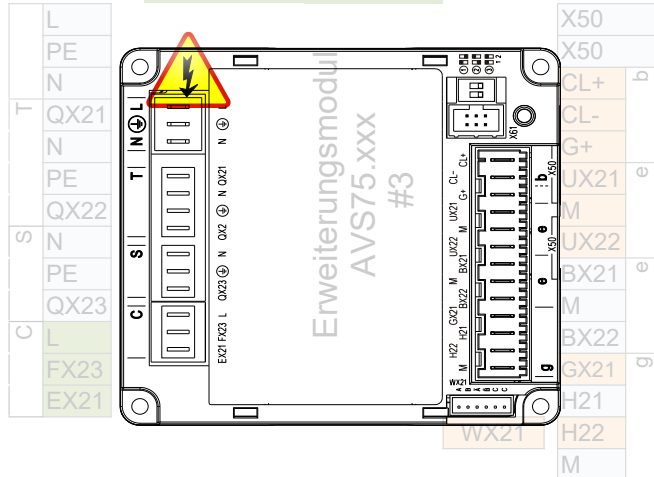

- Bediengerät (HMI) AVS37.xxx
 Erweiterungsmodul AVS75.xxx
 Raumgerät QAA...
 Raumgerät QAA...

Vorsicht: Erweiterungsmodul 3 ist in der Wärmepumpe

Anschlussmöglichkeiten für die Steuerung

1 ControlBox

ControlBox, mit zwei eingebauten Erweiterungsmodulen, ermöglicht zahlreiche Optionen für die Anwendungssteuerung auf der Verbraucherseite hinter der Wärmepumpe. Weitere Informationen finden Sie im Schaltplan der ControlBox und im Blatt mit den Anwendungsdiagrammen.

2 Fixer Sollwert Vorlauftemperatur - Ein / Aus potentialfreier Kontakt

2-adriges abgeschirmtes Kabel 2 x 0,5 mm² - Sollwert = 45°C (editierbar über Parameter 1859)

Anschlussklemme - siehe Schaltplan

3 Analog 0..10V Vorlauftemperatur-Sollwertregelung

2 Adern geschirmtes Kabel 2 x 0,5 mm² - Sollwert: 0V = 16°C ~ 10V = 60°C (editierbar im Parametersatz)

Anschlussklemme - siehe Schaltplan

4 ModBus RTU-Kommunikationsbefehl

3-adriges abgeschirmtes Kabel min. 3 x 0,25mm²

Für die ModBus-Zuordnungstabelle wenden Sie sich bitte an den technischen Support

5 MQTT IoT-Kommunikationsprotokoll

Für weitere Informationen wenden Sie sich bitte an den technischen Support