

Basic performance data - WAMAK AW 200 EVI HeavyDuty 2L2

Heating - EN 14511		
Heating capacity [kW]	A7 / W35	196.3 (49.1 / 196.3)
	A2 / W35	166.8 (41.7 / 166.8)
	A-7 / W34	140.0 (35.0 / 140.0)
Electrical power input [kW]	A7 / W35	45.5 (10.8 / 45.5)
	A2 / W35	45.5 (10.8 / 45.5)
	A-7 / W34	44.2 (10.4 / 44.2)
Heating efficiency faktor [COP]	A7 / W35	4.31
	A2 / W35	3.67
	A-7 / W34	3.17
Seasonal space heating energy efficiency - SCOP EN 14825		
Average Climate / Low Temperature [35 °C]	SCOP	4.23
	η [%]	169.1
	Label	A+++
	Qhe [kWh]	77197.5
	Pdesignh [kW]	158.7
	Tbivalent [°C]	-7
Cooling		
Cooling capacity - [kW]	A35 / W23-18	193.7
	A25 / W23-18	203.6
	A35 / W12-7	145.5
	A25 / W12-7	145.5
Seasonal space cooling energy efficiency - SEER EN 14825		
[W 23 / 18 °C]	SEER	4.54
	Qce [kWh]	87300.0
	η_c [%]	181.6
Sound EN 12102		
Acoustic power - Lw	dB(A)	69.2
Acoustic pressure - Lp	1 m dB(A)	61.2
	5 m dB(A)	47.2
	10 m dB(A)	41.2
Mechanical and operational information		
Compressor type (3~ 400/50)	SCROLL / 4 /	On/Off
Refrigerant	R410A (GWP - 2088)	4 x 9.6 kg
Operating limit temperatures heating - (min / max) [°C]		25 / 65
Operating limit temperatures source - (min / max) [°C]		-22 / 40
Weight		990 kg

Main technical data - WAMAK AW 200 EVI HeavyDuty 2L2

Enclosure type		HD2L2		Heat energy rejection side data		
Basic dimensions	Height [mm]	2000		Operating limit temperatures heating	MAX [°C]	65
	Width [mm]	1500			MIN [°C]	25
	Length [mm]	1200		for more see operating limits diagram		
Weight [kg]	990		Condenser	Port size	4 x 2"	
Colour	Gray			Type	BPHE	
Enclosure IP Class	IP20			Count	4	
Refrigeration cycle				Material	AISI 316	
Compressor	Type	Scroll		Maximal operating pressure - refrigerant [bar]	50	
	Number of stages	4		Maximal operating pressure - Water [bar]	6	
	On/Off			Testing pressure [bar]	70	
	Power factor Cosφ	0.64		Heat transfer medium	Water	
	Winding resistance	0.76 Ohm		Volume flow @ dT 5K (nom) - Water [m3/h]	8.48 ~ 33.91	
Refrigerant		R410A		Internal pressure drop - Water [kPa]	4 x 20	
	Volme	4 x 9.6 kg		Temperature difference	@ 35°C (nom)	5 K
	GWP	2088			@ 55°C	8 K
	Safety class	A1			@ 65°C	10 K
Refrigeration oil type	POE RL32-3MAF			Renewable energy extraction side data		
	Oil volume	4 x 3.38 L		Operating limit temperatures source	MIN [°C]	-22
Maximal pressure - refrigerant [bar]		50			MAX [°C]	40
		PED class	2		for more see operating limits diagram	
EVI - vapour injection with economizer			Evaporator	Port size	4 x (7/8" - 1.3/8")"	
APS System of liquid subcooling				Type	Cu-coil /Al-fin	
Reversible operation (cooling)				Count	4	
Reverse defrosting with hot gas				Material	Cu/Al	
Plate exchanger protection HG-BYPASS			Maximal operating pressure - refrigerant [bar]	29		
Electrical connection data			Heat transfer medium	Air		
Line voltage [#~ V/Hz]	3~ 400/50		Volume flow - Air [m3/h]	15073 ~ 60290		
Current	nominal [A]	94.12		Internal pressure drop - Air [kPa]	4 x 0.061	
	maximal [A]	149.60		Temperature difference - Air	7 K	
	starting [A]	57.2		Possible outdoor units	2 x VOV900X2-FRAME	
Softstart	-		4 x VOII-1200-2LOW			
Main safety	C160		4 x VOII-1200-2HIGH			
Control System			4 x VOII-1200-2LOW-DUCT			
Main controller	SIEMENS	RVS 21 AVS 55.199			4 x VOII-1200-2HIGH-DUCT	
Extension module	AVS75.3xx	AVS75.3xx	AVS75.372	Split System (compressor indoors)		
Bus Clip-In		LPB OCI346	Modbus OCI352	Liquid line dimension (up to 8 meters IU/OU)	4 x 7/8"	
Online connection		Web server OZW672	ToSyMo	Suction line dimension (up to 8 meters IU/OU)	4 x 1.3/8"	
Superheat controller		SEC61		Surcharge of refrigerant over 8 meter distance IU/OU	4 x 0.35 kg/m	
*** with accessory			air - water SPLIT heat pumps indoor units are delivered without full refrigerant charge only with residual overpressure from testing			

WAMAK AW 200 EVI HeavyDuty 2L2

ErP (EU) No 811/2013: Technical parameters for heat pump space heaters

Model	AW 200 EVI HeavyDuty 2L2
Air-to-water heat pump	yes
Brine-to-water heat pump	no
Water-to-water heat pump	no
Low-temperature heat pump	no
Equipped with a supplementary heater	no
Heat pump combination heater	no
Temperature application	low (35°C - 30°C)
Climate conditions	average

Item	Symbol	Value	Unit	Item	Symbol	Value	Unit
Rated heat output at Tdesignh	Prated	158.7	kW	Seasonal space heating energy efficiency	η_s	169.1	%
Declared capacity for heating for part load at indoor temperature 20 °C and outdoor temperature Tj				Declared coefficient of performance or primary energy ratio for part load at indoor temperature 20 °C and outdoor temperature Tj			
Tj = -7 °C	Pdh	140.0	kW	Tj = -7 °C	COPd	3.17	-
Tj = +2 °C	Pdh	165.0	kW	Tj = +2 °C	COPd	4.1	-
Tj = +7 °C	Pdh	194.4	kW	Tj = +7 °C	COPd	5.1	-
Tj = +12 °C	Pdh	229.8	kW	Tj = +12 °C	COPd	6.4	-
Tj = bivalent temperature	Pdh	137.6	kW	Tj = bivalent temperature	COPd	3.1	-
Tj = operation limit temperature	Pdh	100.4	kW	Tj = operation limit temperature	COPd	2.3	-
Bivalent temperature	Tbiv	-7	°C	Tj = operation limit temperature	TOL	-22	°C
Power consumption in modes other than active mode				Heating water operating limit temperature	WTOL	65	°C
Off mode	Poff	0.040	kW	Supplementary heater			
Thermostat-off mode	Pto	0.010	kW	Rated heat output	Psup	70.4	kW
Standby mode	Psb	0.010	kW	Type of energy input	electricity		
Crankcase heater mode	Pck	0.050	kW	For air-to-water heat pumps:			
Other items				Rated air flow rate, outdoors	-	15073 ~ 60290	m ³ /h
Capacity control	multi-stage			For water- or brine-to-water heat pumps: Rated brine or water flow rate, outdoor heat exchanger			
Sound power level							
indoors	Lwa	69	dB				
outdoors	Lwa	76	dB				
Annual energy consumption	Q _{HE}	77197.5	kWh				

Contact details: WAMAK, s.r.o., Orovnicna 252, 96652, Orovnicna, Slovakia, info@wamak.sk

WAMAK AW 200 EVI HeavyDuty 2L2

ErP (EU) No 811/2013: Technical parameters for heat pump space heaters

Model	AW 200 EVI HeavyDuty 2L2
Air-to-water heat pump	yes
Brine-to-water heat pump	no
Water-to-water heat pump	no
Low-temperature heat pump	no
Equipped with a supplementary heater	no
Heat pump combination heater	no
Temperature application	middle (55°C - 47°C)
Climate conditions	average

Item	Symbol	Value	Unit	Item	Symbol	Value	Unit
Rated heat output at Tdesignh	Prated	166.5	kW	Seasonal space heating energy efficiency	η_s	132.4	%
Declared capacity for heating for part load at indoor temperature 20 °C and outdoor temperature Tj				Declared coefficient of performance or primary energy ratio for part load at indoor temperature 20 °C and outdoor temperature Tj			
Tj = -7 °C	Pdh	146.3	kW	Tj = -7 °C	COPd	2.24	-
Tj = +2 °C	Pdh	169.0	kW	Tj = +2 °C	COPd	3.2	-
Tj = +7 °C	Pdh	196.6	kW	Tj = +7 °C	COPd	4.2	-
Tj = +12 °C	Pdh	230.3	kW	Tj = +12 °C	COPd	5.6	-
Tj = bivalent temperature	Pdh	144.5	kW	Tj = bivalent temperature	COPd	2.1	-
Tj = operation limit temperature	Pdh	105.8	kW	Tj = operation limit temperature	COPd	1.6	-
Bivalent temperature	Tbiv	-7	°C	Tj = operation limit temperature	TOL	-22	°C
Power consumption in modes other than active mode				Heating water operating limit temperature	WTOL	65	°C
Off mode	Poff	0.040	kW	Supplementary heater			
Thermostat-off mode	Pto	0.010	kW	Rated heat output	Psup	70.4	kW
Standby mode	Psb	0.010	kW	Type of energy input	electricity		
Crankcase heater mode	Pck	0.050	kW	For air-to-water heat pumps:			
Other items				Rated air flow rate, outdoors	-	15073 ~ 60290	m ³ /h
Capacity control	multi-stage			For water- or brine-to-water heat pumps: Rated brine or water flow rate, outdoor heat exchanger			
Sound power level							
indoors	Lwa	69	dB				
outdoors	Lwa	76	dB				
Annual energy consumption	Q _{HE}	103602.2	kWh				

Contact details: WAMAK, s.r.o., Orovnicna 252, 96652, Orovnicna, Slovakia, info@wamak.sk



ENERG Y IIA
 енергия - ενεργεια IE IA



AW 200 EVI

HeavyDuty 2L2

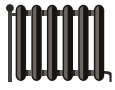

55 °C

35 °C



69 dB

76 dB

Two icons representing sound power levels: a speaker icon for 69 dB and a house icon for 76 dB.

■ 175	■ 162
■ 167	■ 159
■ 164	■ 151
kW	kW

A map of Europe with a blue shaded area indicating the region of application.

2019

811/2013

AW 200 EVI HeavyDuty
2L2

ErP Data

	55 °C	35 °C
Energy class	A++	A+++
η [%]	132.4	169.1
P_{rated} [kW]	167	159
Q_{HE} [kWh/y]	103603	77198
SCOP [-]	3.31	4.23
$T_{bivalent}$ [°C]	-7	-7

CONTROLLER



+ QAA55/75 class VII 3.5% ↓
 - QAA55/75 class III 1.5% ↓

Heating performance data

Version: v2024.010-AW

Average Climate / Low Temperature [35°C]

ZHI46K1P-TWD_R410A_4_AW

Operating conditions		Qh	P	COP
1	A7 / W30-35	196.3	45.5	4.31
2	A2 / W35	166.8	45.5	3.67
3	A-22 / W35	100.4	43.4	2.31
A	A-7 / W34	140.0	44.2	3.17
B	A2 / W30	165.0	40.6	4.06
C	A7 / W27	194.4	38.0	5.11
D	A12 / W24	229.8	35.8	6.41
E	A-10 / W35	137.6	45.1	3.05
F	A-7 / W34	140.0	44.2	3.17

SCOP DATA EN 14825:2018	
Average Climate / Low Temperature [35°C]	
SCOPon	4.25
SCOPnet	4.29
SCOP	4.23
η [%]	169.11
Label	A+++
Qh [kWh]	77197.49
Pdesignh [kW]	158.7
Tbivalent [°C]	-7.00

Average Climate / Medium Temperature [55°C]

Operating conditions		Qh	P	COP
1	A7 / W47-55	200.4	71.4	2.81
2	A2 / W55	172.8	70.9	2.44
3	A-22 / W55	105.8	60.7	1.62
A	A-7 / W52	146.3	65.3	2.24
B	A2 / W42	169.0	53.1	3.18
C	A7 / W36	196.6	46.6	4.22
D	A12 / W30	230.3	40.9	5.64
E	A-10 / W55	144.5	69.6	2.08
F	A-7 / W55	147.3	69.7	2.11

SCOP DATA EN 14825:2018	
Average Climate / Medium Temperature [55°C]	
SCOPon	3.32
SCOPnet	3.34
SCOP	3.31
η [%]	132.35
Label	A++
Qh [kWh]	103602.22
Pdesignh [kW]	166.5
Tbivalent [°C]	-7.00

Cooling performance data

Low temperature cooling W 12 / 7°C

Operating conditions		Qc	P	EER
A	A35 / W12-7	145.5	54.4	2.68
B	A30 / W12-7	149.6	48.7	3.07
C	A25 / W12-7	152.9	43.6	3.51
D	A20 / W12-7	155.7	38.9	4.00

SEER DATA EN 14825:2018 [W 12 / 7°C]	
SEERon	3.43
SEER	3.41
Qc [kWh]	32046.56
η [%]	136.57

Radiant cooling W 23 / 18°C

Operating conditions		Qc	P	EER
A	A35 / W23-18	193.7	54.4	3.56
B	A30 / W23-18	199.0	45.1	4.09
C	A25 / W23-18	203.6	40.5	4.67
D	A20 / W23-18	207.7	36.4	5.34

SEER DATA EN 14825:2018 [W 23 / 18°C]	
SEERon	4.57
SEER	4.54
Qc [kWh]	24067.99
η [%]	181.58

WAMAK AW 200 EVI HeavyDuty 2L2

ZHI46K1P-TWD_R410A_4_AW

Performance lines - heating

- Qh-nom-35 — Qh-min-35 - - - Qh-max-65 — Qh-nom-45 — Qh-nom-55
- Qh-nom-65 — Pratedh-35 — Pratedh-55

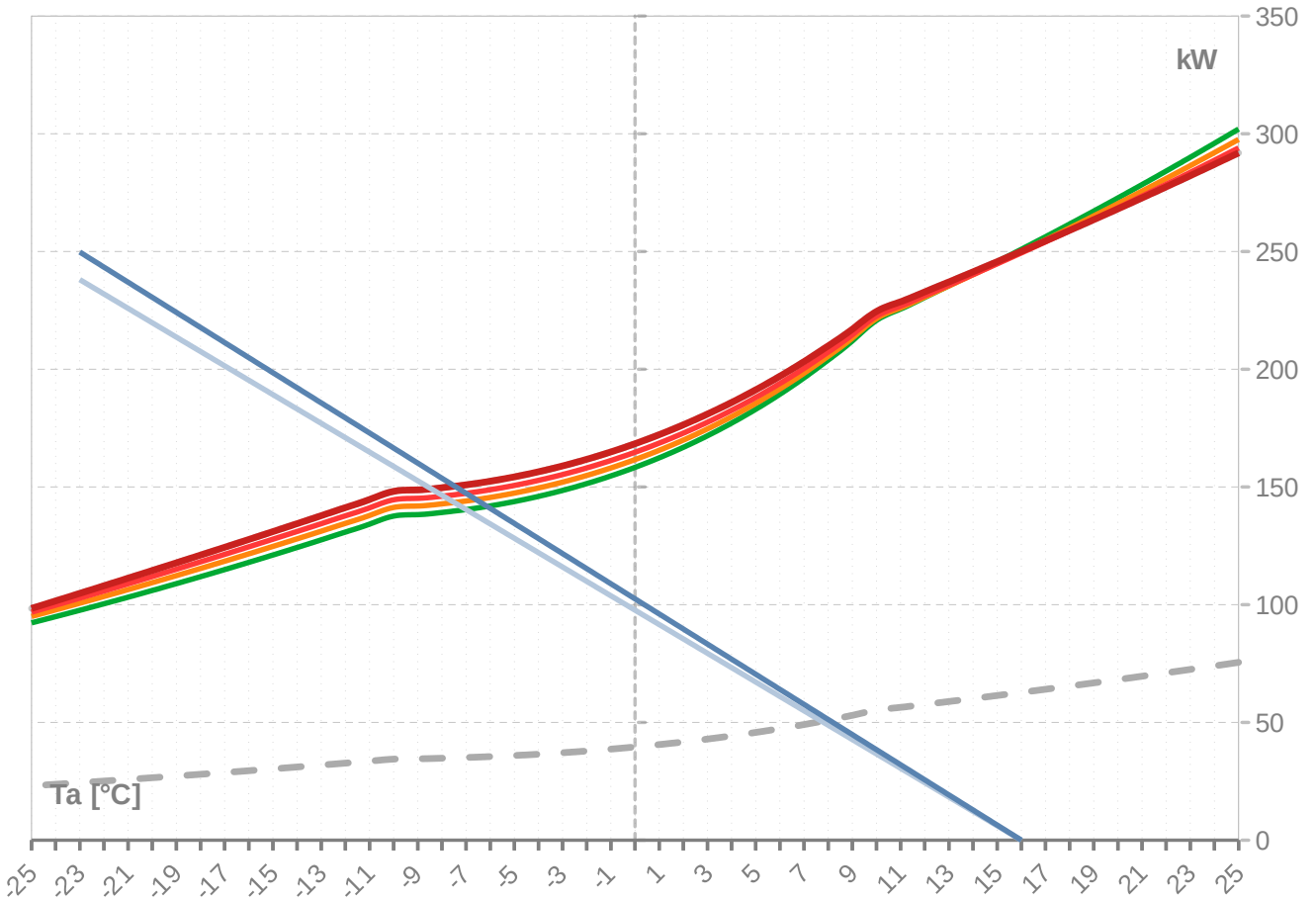

Performance lines - cooling

- Pratedc — Qc-12/7 — Qc-23/18

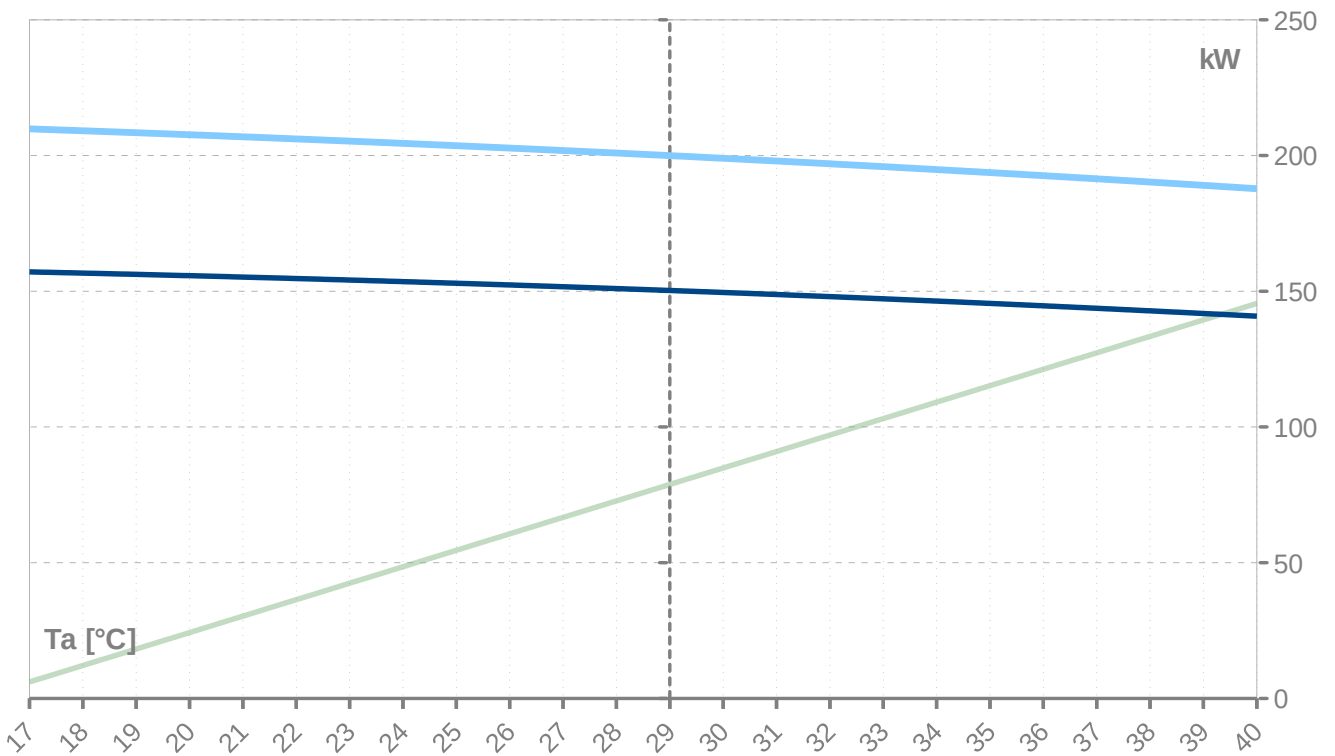

WAMAK AW 200 EVI HeavyDuty 2L2

Th [°C]		35 °C								
Ta [°C]	Qh nom [kW]	Qh min [kW]	Qh max [kW]	Pin nom [kW]	Pin-min [kW]	Pin-max [kW]	COP kW / kW	I nom [A]	I min [A]	I max [A]
25	256.2	64.1		45.6	10.8		5.62	93.1	23.3	
24	256.2	64.1		45.6	10.8		5.62	93.1	23.3	
23	256.2	64.1		45.6	10.8		5.62	93.1	23.3	
22	256.2	64.1		45.6	10.8		5.62	93.1	23.3	
21	256.2	64.1		45.6	10.8		5.62	93.1	23.3	
20	256.2	64.1		45.6	10.8		5.62	93.1	23.3	
19	256.2	64.1		45.6	10.8		5.62	93.1	23.3	
18	256.2	64.1		45.6	10.8		5.62	93.1	23.3	
17	256.2	64.1		45.6	10.8		5.62	93.1	23.3	
16	250.9	62.7	250.9	45.5	10.8	45.5	5.51	93.2	23.3	93.2
15	245.7	61.4	245.7	45.5	10.8	45.5	5.40	93.2	23.3	93.2
14	240.5	60.1	240.5	45.5	10.8	45.5	5.28	93.3	23.3	93.3
13	235.5	58.9	235.5	45.5	10.8	45.5	5.17	93.4	23.4	93.4
12	230.5	57.6	230.5	45.5	10.8	45.5	5.06	93.5	23.4	93.5
11	225.6	56.4	225.6	45.5	10.8	45.5	4.96	93.6	23.4	93.6
10	220.7	55.2	220.7	45.5	10.8	45.5	4.85	93.7	23.4	93.7
9	212.0	53.0	212.0	45.5	10.8	45.5	4.66	93.9	23.5	93.9
8	203.9	51.0	203.9	45.5	10.8	45.5	4.48	94.1	23.5	94.1
7	196.3	49.1	196.3	45.5	10.8	45.5	4.31	94.3	23.6	94.3
6	189.4	47.3	189.4	45.5	10.8	45.5	4.16	94.5	23.6	94.5
5	183.0	45.7	183.0	45.5	10.8	45.5	4.02	94.6	23.7	94.6
4	177.1	44.3	177.1	45.5	10.8	45.5	3.89	94.7	23.7	94.7
3	171.7	42.9	171.7	45.5	10.8	45.5	3.77	94.8	23.7	94.8
2	166.8	41.7	166.8	45.5	10.8	45.5	3.67	94.9	23.7	94.9
1	162.3	40.6	162.3	45.5	10.7	45.5	3.57	94.9	23.7	94.9
0	158.3	39.6	158.3	45.4	10.7	45.4	3.49	95.0	23.7	95.0
-1	154.7	38.7	154.7	45.4	10.7	45.4	3.41	95.0	23.7	95.0
-2	151.4	37.9	151.4	45.3	10.7	45.3	3.34	95.0	23.7	95.0
-3	148.5	37.1	148.5	45.3	10.7	45.3	3.28	95.0	23.7	95.0
-4	146.0	36.5	146.0	45.3	10.7	45.3	3.22	95.0	23.7	95.0
-5	143.8	35.9	143.8	45.2	10.7	45.2	3.18	94.9	23.7	94.9
-6	141.9	35.5	141.9	45.2	10.7	45.2	3.14	94.9	23.7	94.9
-7	140.4	35.1	140.4	45.2	10.7	45.2	3.11	94.9	23.7	94.9
-8	139.2	34.8	139.2	45.1	10.7	45.1	3.08	94.9	23.7	94.9
-9	138.2	34.6	138.2	45.1	10.7	45.1	3.06	94.8	23.7	94.8
-10	137.6	34.4	137.6	45.1	10.7	45.1	3.05	94.8	23.7	94.8
-11	134.2	33.5	134.2	45.0	10.6	45.0	2.98	94.7	23.7	94.7
-12	130.8	32.7	130.8	44.9	10.6	44.9	2.91	94.6	23.7	94.6
-13	127.5	31.9	127.5	44.8	10.6	44.8	2.84	94.5	23.6	94.5
-14	124.3	31.1	124.3	44.7	10.6	44.7	2.78	94.3	23.6	94.3
-15	121.1	30.3	121.1	44.6	10.5	44.6	2.72	94.1	23.5	94.1
-16	118.0	29.5	118.0	44.5	10.5	44.5	2.65	93.9	23.5	93.9
-17	114.9	28.7	114.9	44.3	10.5	44.3	2.59	93.7	23.4	93.7
-18	111.9	28.0	111.9	44.1	10.4	44.1	2.53	93.4	23.3	93.4
-19	108.9	27.2	108.9	44.0	10.4	44.0	2.48	93.1	23.3	93.1
-20	106.0	26.5	106.0	43.8	10.4	43.8	2.42	92.7	23.2	92.7
-21	103.2	25.8	103.2	43.6	10.3	43.6	2.37	92.4	23.1	92.4
-22	100.4	25.1	100.4	43.4	10.3	43.4	2.31	91.9	23.0	91.9
-23	97.6	24.4	97.6	43.1	10.2	43.1	2.26	91.5	22.9	91.5
-24	94.9	23.7	94.9	42.9	10.1	42.9	2.21	91.0	22.8	91.0
-25	92.3	23.1	92.3	42.6	10.1	42.6	2.17	90.5	22.6	90.5

* attention: operating limits not reflected in performance table

ZHI46K1P-TWD_R410A_4_AW

Th [°C]		45 °C								
Ta [°C]	Qh nom [kW]	Qh min [kW]	Qh max [kW]	Pin nom [kW]	Pin-min [kW]	Pin-max [kW]	COP kW / kW	I nom [A]	I min [A]	I max [A]
25	297.6	74.4	297.6	56.4	13.3	56.4	5.27	106.1	26.5	106.1
24	292.0	73.0	292.0	56.4	13.3	56.4	5.17	106.1	26.5	106.1
23	286.4	71.6	286.4	56.5	13.3	56.5	5.07	106.1	26.5	106.1
22	281.0	70.2	281.0	56.5	13.4	56.5	4.98	106.1	26.5	106.1
21	275.6	68.9	275.6	56.5	13.4	56.5	4.88	106.1	26.5	106.1
20	270.3	67.6	270.3	56.5	13.4	56.5	4.78	106.1	26.5	106.1
19	265.1	66.3	265.1	56.5	13.4	56.5	4.69	106.1	26.5	106.1
18	260.0	65.0	260.0	56.6	13.4	56.6	4.60	106.2	26.5	106.2
17	254.9	63.7	254.9	56.6	13.4	56.6	4.50	106.2	26.6	106.2
16	249.9	62.5	249.9	56.6	13.4	56.6	4.41	106.3	26.6	106.3
15	245.0	61.2	245.0	56.7	13.4	56.7	4.32	106.3	26.6	106.3
14	240.1	60.0	240.1	56.7	13.4	56.7	4.24	106.3	26.6	106.3
13	235.4	58.8	235.4	56.7	13.4	56.7	4.15	106.4	26.6	106.4
12	230.7	57.7	230.7	56.7	13.4	56.7	4.07	106.4	26.6	106.4
11	226.0	56.5	226.0	56.8	13.4	56.8	3.98	106.5	26.6	106.5
10	221.5	55.4	221.5	56.8	13.4	56.8	3.90	106.5	26.6	106.5
9	213.2	53.3	213.2	56.8	13.4	56.8	3.75	106.6	26.6	106.6
8	205.5	51.4	205.5	56.8	13.4	56.8	3.62	106.6	26.7	106.6
7	198.3	49.6	198.3	56.9	13.4	56.9	3.49	106.6	26.7	106.6
6	191.6	47.9	191.6	56.8	13.4	56.8	3.37	106.6	26.7	106.6
5	185.5	46.4	185.5	56.8	13.4	56.8	3.26	106.6	26.6	106.6
4	179.8	45.0	179.8	56.8	13.4	56.8	3.17	106.5	26.6	106.5
3	174.6	43.7	174.6	56.8	13.4	56.8	3.08	106.4	26.6	106.4
2	169.9	42.5	169.9	56.7	13.4	56.7	3.00	106.3	26.6	106.3
1	165.6	41.4	165.6	56.6	13.4	56.6	2.92	106.2	26.5	106.2
0	161.6	40.4	161.6	56.6	13.4	56.6	2.86	106.0	26.5	106.0
-1	158.1	39.5	158.1	56.5	13.4	56.5	2.80	105.9	26.5	105.9
-2	154.9	38.7	154.9	56.4	13.3	56.4	2.74	105.7	26.4	105.7
-3	152.0	38.0	152.0	56.3	13.3	56.3	2.70	105.6	26.4	105.6
-4	149.5	37.4	149.5	56.3	13.3	56.3	2.66	105.4	26.4	105.4
-5	147.4	36.8	147.4	56.2	13.3	56.2	2.62	105.3	26.3	105.3
-6	145.5	36.4	145.5	56.1	13.3	56.1	2.59	105.1	26.3	105.1
-7	144.0	36.0	144.0	56.1	13.3	56.1	2.57	105.0	26.3	105.0
-8	142.8	35.7	142.8	56.0	13.3	56.0	2.55	104.9	26.2	104.9
-9	141.9	35.5	141.9	56.0	13.2	56.0	2.53	104.8	26.2	104.8
-10	141.3	35.3	141.3	56.0	13.2	56.0	2.52	104.8	26.2	104.8
-11	137.9	34.5	137.9	55.8	13.2	55.8	2.47	104.5	26.1	104.5
-12	134.5	33.6	134.5	55.7	13.2	55.7	2.42	104.1	26.0	104.1
-13	131.2	32.8	131.2	55.5	13.1	55.5	2.36	103.8	25.9	103.8
-14	127.9	32.0	127.9	55.3	13.1	55.3	2.31	103.4	25.8	103.4
-15	124.7	31.2	124.7	55.1	13.0	55.1	2.26	102.9	25.7	102.9
-16	121.6	30.4	121.6	54.9	13.0	54.9	2.21	102.5	25.6	102.5
-17	118.4	29.6	118.4	54.7	12.9	54.7	2.17	102.0	25.5	102.0
-18	115.4	28.8	115.4	54.4	12.9	54.4	2.12	101.4	25.4	101.4
-19	112.3	28.1	112.3	54.1	12.8	54.1	2.07	100.9	25.2	100.9
-20	109.3	27.3	109.3	53.9	12.7	53.9	2.03	100.2	25.1	100.2
-21	106.4	26.6	106.4	53.5	12.7	53.5	1.99	99.6	24.9	99.6
-22	103.5	25.9	103.5	53.2	12.6	53.2	1.94	98.9	24.7	98.9
-23	100.6	25.2	100.6	52.9	12.5	52.9	1.90	98.1	24.5	98.1
-24	97.8	24.4	97.8	52.5	12.4	52.5	1.86	97.3	24.3	97.3
-25	95.0	23.7	95.0	52.1	12.3	52.1	1.82	96.5	24.1	96.5

* attention: operating limits not reflected in performance table

WAMAK AW 200 EVI HeavyDuty 2L2

Th [°C]		55 °C								
Ta [°C]	Qh nom [kW]	Qh min [kW]	Qh max [kW]	Pin nom [kW]	Pin-min [kW]	Pin-max [kW]	COP kW / kW	I nom [A]	I min [A]	I max [A]
25	294.0	73.5	294.0	70.9	16.8	70.9	4.15	122.6	30.7	122.6
24	288.8	72.2	288.8	70.9	16.8	70.9	4.07	122.6	30.7	122.6
23	283.6	70.9	283.6	71.0	16.8	71.0	3.99	122.7	30.7	122.7
22	278.5	69.6	278.5	71.0	16.8	71.0	3.92	122.7	30.7	122.7
21	273.5	68.4	273.5	71.1	16.8	71.1	3.85	122.8	30.7	122.8
20	268.5	67.1	268.5	71.1	16.8	71.1	3.77	122.8	30.7	122.8
19	263.6	65.9	263.6	71.2	16.8	71.2	3.70	122.8	30.7	122.8
18	258.8	64.7	258.8	71.2	16.8	71.2	3.63	122.9	30.7	122.9
17	254.1	63.5	254.1	71.3	16.9	71.3	3.56	122.9	30.7	122.9
16	249.4	62.3	249.4	71.3	16.9	71.3	3.50	123.0	30.7	123.0
15	244.7	61.2	244.7	71.3	16.9	71.3	3.43	123.0	30.8	123.0
14	240.2	60.0	240.2	71.4	16.9	71.4	3.36	123.0	30.8	123.0
13	235.7	58.9	235.7	71.4	16.9	71.4	3.30	123.1	30.8	123.1
12	231.2	57.8	231.2	71.4	16.9	71.4	3.24	123.1	30.8	123.1
11	226.8	56.7	226.8	71.4	16.9	71.4	3.17	123.1	30.8	123.1
10	222.5	55.6	222.5	71.5	16.9	71.5	3.11	123.1	30.8	123.1
9	214.6	53.7	214.6	71.5	16.9	71.5	3.00	123.1	30.8	123.1
8	207.3	51.8	207.3	71.4	16.9	71.4	2.90	123.0	30.7	123.0
7	200.4	50.1	200.4	71.4	16.9	71.4	2.81	122.9	30.7	122.9
6	193.9	48.5	193.9	71.3	16.9	71.3	2.72	122.7	30.7	122.7
5	188.0	47.0	188.0	71.2	16.8	71.2	2.64	122.5	30.6	122.5
4	182.5	45.6	182.5	71.1	16.8	71.1	2.57	122.3	30.6	122.3
3	177.5	44.4	177.5	71.0	16.8	71.0	2.50	122.1	30.5	122.1
2	172.8	43.2	172.8	70.9	16.8	70.9	2.44	121.8	30.5	121.8
1	168.6	42.1	168.6	70.8	16.7	70.8	2.38	121.5	30.4	121.5
0	164.7	41.2	164.7	70.6	16.7	70.6	2.33	121.3	30.3	121.3
-1	161.2	40.3	161.2	70.5	16.7	70.5	2.29	121.0	30.2	121.0
-2	158.1	39.5	158.1	70.3	16.6	70.3	2.25	120.7	30.2	120.7
-3	155.3	38.8	155.3	70.2	16.6	70.2	2.21	120.4	30.1	120.4
-4	152.8	38.2	152.8	70.1	16.6	70.1	2.18	120.1	30.0	120.1
-5	150.6	37.7	150.6	69.9	16.5	69.9	2.15	119.9	30.0	119.9
-6	148.8	37.2	148.8	69.8	16.5	69.8	2.13	119.7	29.9	119.7
-7	147.3	36.8	147.3	69.7	16.5	69.7	2.11	119.5	29.9	119.5
-8	146.1	36.5	146.1	69.7	16.5	69.7	2.10	119.3	29.8	119.3
-9	145.1	36.3	145.1	69.6	16.5	69.6	2.09	119.2	29.8	119.2
-10	144.5	36.1	144.5	69.6	16.4	69.6	2.08	119.1	29.8	119.1
-11	141.1	35.3	141.1	69.3	16.4	69.3	2.04	118.6	29.7	118.6
-12	137.7	34.4	137.7	69.1	16.3	69.1	1.99	118.1	29.5	118.1
-13	134.4	33.6	134.4	68.8	16.3	68.8	1.95	117.5	29.4	117.5
-14	131.1	32.8	131.1	68.5	16.2	68.5	1.91	116.9	29.2	116.9
-15	127.8	31.9	127.8	68.2	16.1	68.2	1.87	116.3	29.1	116.3
-16	124.6	31.1	124.6	67.8	16.0	67.8	1.84	115.6	28.9	115.6
-17	121.4	30.3	121.4	67.5	16.0	67.5	1.80	114.8	28.7	114.8
-18	118.2	29.5	118.2	67.1	15.9	67.1	1.76	114.1	28.5	114.1
-19	115.0	28.8	115.0	66.7	15.8	66.7	1.72	113.2	28.3	113.2
-20	111.9	28.0	111.9	66.3	15.7	66.3	1.69	112.4	28.1	112.4
-21	108.8	27.2	108.8	65.9	15.6	65.9	1.65	111.5	27.9	111.5
-22	105.8	26.4	105.8	65.4	15.5	65.4	1.62	110.5	27.6	110.5
-23	102.8	25.7	102.8	64.9	15.3	64.9	1.58	109.5	27.4	109.5
-24	99.8	24.9	99.8	64.4	15.2	64.4	1.55	108.4	27.1	108.4
-25	96.8	24.2	96.8	63.8	15.1	63.8	1.52	107.3	26.8	107.3

* attention: operating limits not reflected in performance table

WAMAK AW 200 EVI HeavyDuty 2L2

Th [°C]		T-Max @ 65 °C								
Ta [°C]	Qh nom [kW]	Qh min [kW]	Qh max [kW]	Pin nom [kW]	Pin-min [kW]	Pin-max [kW]	COP kW / kW	I nom [A]	I min [A]	I max [A]
25	291.9	73.0	291.9	90.4	21.4	90.4	3.23	144.6	36.1	144.6
24	287.0	71.8	287.0	90.4	21.4	90.4	3.17	144.7	36.2	144.7
23	282.2	70.5	282.2	90.5	21.4	90.5	3.12	144.8	36.2	144.8
22	277.4	69.4	277.4	90.5	21.4	90.5	3.06	144.9	36.2	144.9
21	272.7	68.2	272.7	90.6	21.4	90.6	3.01	145.0	36.2	145.0
20	268.1	67.0	268.1	90.6	21.4	90.6	2.96	145.1	36.3	145.1
19	263.5	65.9	263.5	90.7	21.4	90.7	2.91	145.2	36.3	145.2
18	259.0	64.7	259.0	90.7	21.4	90.7	2.86	145.2	36.3	145.2
17	254.5	63.6	254.5	90.7	21.4	90.7	2.81	145.3	36.3	145.3
16	250.1	62.5	250.1	90.7	21.5	90.7	2.76	145.4	36.3	145.4
15	245.7	61.4	245.7	90.7	21.5	90.7	2.71	145.4	36.4	145.4
14	241.3	60.3	241.3	90.7	21.5	90.7	2.66	145.5	36.4	145.5
13	237.1	59.3	237.1	90.7	21.5	90.7	2.61	145.5	36.4	145.5
12	232.8	58.2	232.8	90.7	21.5	90.7	2.57	145.5	36.4	145.5
11	228.7	57.2	228.7	90.7	21.4	90.7	2.52	145.5	36.4	145.5
10	224.5	56.1	224.5	90.7	21.4	90.7	2.48	145.5	36.4	145.5
9	217.0	54.2	217.0	90.6	21.4	90.6	2.40	145.5	36.4	145.5
8	209.9	52.5	209.9	90.5	21.4	90.5	2.32	145.3	36.3	145.3
7	203.2	50.8	203.2	90.3	21.3	90.3	2.25	145.1	36.3	145.1
6	197.0	49.3	197.0	90.1	21.3	90.1	2.19	144.9	36.2	144.9
5	191.2	47.8	191.2	89.9	21.3	89.9	2.13	144.6	36.2	144.6
4	185.9	46.5	185.9	89.7	21.2	89.7	2.07	144.3	36.1	144.3
3	180.9	45.2	180.9	89.5	21.2	89.5	2.02	143.9	36.0	143.9
2	176.4	44.1	176.4	89.2	21.1	89.2	1.98	143.6	35.9	143.6
1	172.2	43.0	172.2	89.0	21.0	89.0	1.94	143.2	35.8	143.2
0	168.3	42.1	168.3	88.7	21.0	88.7	1.90	142.8	35.7	142.8
-1	164.9	41.2	164.9	88.5	20.9	88.5	1.86	142.4	35.6	142.4
-2	161.7	40.4	161.7	88.2	20.9	88.2	1.83	142.0	35.5	142.0
-3	158.9	39.7	158.9	88.0	20.8	88.0	1.81	141.6	35.4	141.6
-4	156.4	39.1	156.4	87.8	20.8	87.8	1.78	141.2	35.3	141.2
-5	154.3	38.6	154.3	87.6	20.7	87.6	1.76	140.9	35.2	140.9
-6	152.4	38.1	152.4	87.4	20.7	87.4	1.74	140.6	35.1	140.6
-7	150.9	37.7	150.9	87.3	20.6	87.3	1.73	140.3	35.1	140.3
-8	149.7	37.4	149.7	87.2	20.6	87.2	1.72	140.1	35.0	140.1
-9	148.7	37.2	148.7	87.1	20.6	87.1	1.71	140.0	35.0	140.0
-10	148.1	37.0	148.1	87.0	20.6	87.0	1.70	139.8	35.0	139.8
-11	144.6	36.2	144.6	86.6	20.5	86.6	1.67	139.2	34.8	139.2
-12	141.2	35.3	141.2	86.2	20.4	86.2	1.64	138.5	34.6	138.5
-13	137.8	34.4	137.8	85.8	20.3	85.8	1.61	137.8	34.4	137.8
-14	134.4	33.6	134.4	85.4	20.2	85.4	1.57	137.0	34.2	137.0
-15	131.0	32.8	131.0	84.9	20.1	84.9	1.54	136.1	34.0	136.1
-16										
-17										
-18										
-19										
-20										
-21										
-22										
-23										
-24										
-25										

* attention: operating limits not reflected in performance table

WAMAK AW 200 EVI HeavyDuty 2L2

Tc [°C]		W 12 / 7 °C								
Ta [°C]	Qc nom [kW]	Qc min [kW]	Qc max [kW]	Pin [kW]	Pin min [kW]	Pin max [kW]	EER kW / kW	I nom [A]	I min [A]	I max [A]
40	140.8	140.8	140.8	60.8	57.5	60.8	2.32	111.0	111.0	111.0
39	141.8	141.8	141.8	59.5	56.2	59.5	2.38	109.5	109.5	109.5
38	142.8	142.8	142.8	58.1	55.0	58.1	2.46	108.0	108.0	108.0
37	143.7	143.7	143.7	56.9	53.8	56.9	2.53	106.6	106.6	106.6
36	144.6	144.6	144.6	55.6	52.6	55.6	2.60	105.2	105.2	105.2
35	145.5	145.5	145.5	54.4	51.4	54.4	2.68	103.9	103.9	103.9
34	146.4	146.4	146.4	53.2	50.3	53.2	2.75	102.6	102.6	102.6
33	147.2	147.2	147.2	52.0	49.2	52.0	2.83	101.4	101.4	101.4
32	148.0	148.0	148.0	50.9	48.1	50.9	2.91	100.1	100.1	100.1
31	148.8	148.8	148.8	49.8	47.1	49.8	2.99	98.9	98.9	98.9
30	149.6	149.6	149.6	48.7	46.0	48.7	3.07	97.8	97.8	97.8
29	150.3	150.3	150.3	47.6	45.0	47.6	3.16	96.6	96.6	96.6
28	151.0	151.0	151.0	46.6	44.0	46.6	3.24	95.5	95.5	95.5
27	151.7	151.7	151.7	45.5	43.1	45.5	3.33	94.4	94.4	94.4
26	152.3	152.3	152.3	44.5	42.1	44.5	3.42	93.3	93.3	93.3
25	152.9	152.9	152.9	43.6	41.2	43.6	3.51	92.2	92.2	92.2
24	153.6	153.6	153.6	42.6	40.3	42.6	3.60	91.2	91.2	91.2
23	154.1	154.1	154.1	41.7	39.4	41.7	3.70	90.2	90.2	90.2
22	154.7	154.7	154.7	40.7	38.5	40.7	3.80	89.1	89.1	89.1
21	155.2	155.2	155.2	39.8	37.6	39.8	3.90	88.1	88.1	88.1
20	155.7	155.7	155.7	38.9	36.8	38.9	4.00	87.1	87.1	87.1
19	156.2	156.2	156.2	38.0	36.0	38.0	4.11	86.1	86.1	86.1
18	156.7	156.7	156.7	37.1	35.1	37.1	4.22	85.1	85.1	85.1
17	157.1	157.1	157.1	36.3	34.3	36.3	4.33	84.1	84.1	84.1

Tc [°C]		W 23 / 18 °C								
Ta [°C]	Qc [kW]	Qh-min [kW]	Qh-max [kW]	Pin [kW]	Pin-min [kW]	Pin-max [kW]	EER kW / kW	I [A]	I-min [A]	I-max [A]
40	187.8	187.8	187.8	60.8	57.5	60.8	3.09	110.9	110.9	110.9
39	189.0	189.0	189.0	59.5	56.2	59.5	3.18	109.3	109.3	109.3
38	190.2	190.2	190.2	58.1	55.0	58.1	3.27	107.8	107.8	107.8
37	191.4	191.4	191.4	56.9	53.8	56.9	3.37	106.3	106.3	106.3
36	192.6	192.6	192.6	55.6	52.6	55.6	3.46	104.9	104.9	104.9
35	193.7	193.7	193.7	54.4	51.4	54.4	3.56	103.5	103.5	103.5
34	194.8	194.8	194.8	53.2	50.3	53.2	3.66	102.1	102.1	102.1
33	195.9	195.9	195.9	52.0	49.2	52.0	3.77	100.8	100.8	100.8
32	196.9	196.9	196.9	50.9	48.1	50.9	3.87	99.5	99.5	99.5
31	198.0	198.0	198.0	49.8	47.1	49.8	3.98	98.2	98.2	98.2
30	199.0	199.0	199.0	48.7	46.0	48.7	4.09	96.9	96.9	96.9
29	200.0	200.0	200.0	47.6	45.0	47.6	4.20	95.7	95.7	95.7
28	200.9	200.9	200.9	46.6	44.0	46.6	4.32	94.5	94.5	94.5
27	201.8	201.8	201.8	45.5	43.1	45.5	4.43	93.3	93.3	93.3
26	202.7	202.7	202.7	44.5	42.1	44.5	4.55	92.1	92.1	92.1
25	203.6	203.6	203.6	43.6	41.2	43.6	4.67	90.9	90.9	90.9
24	204.5	204.5	204.5	42.6	40.3	42.6	4.80	89.8	89.8	89.8
23	205.3	205.3	205.3	41.7	39.4	41.7	4.93	88.7	88.7	88.7
22	206.1	206.1	206.1	40.7	38.5	40.7	5.06	87.5	87.5	87.5
21	206.9	206.9	206.9	39.8	37.6	39.8	5.20	86.4	86.4	86.4
20	207.7	207.7	207.7	38.9	36.8	38.9	5.34	85.3	85.3	85.3
19	208.4	208.4	208.4	38.0	36.0	38.0	5.48	84.1	84.1	84.1
18	209.1	209.1	209.1	37.1	35.1	37.1	5.63	83.0	83.0	83.0
17	209.8	209.8	209.8	36.3	34.3	36.3	5.78	81.9	81.9	81.9

* attention: operating limits not reflected in performance table

LEGENDE:

Ts-IN: Temperature renewable source - inlet [°C]
Th-OU: Temperature heating - outlet (flow) [°C]
Tc-OU: Temperature cooling - outlet (flow) [°C]
Qh nom: Heating capacity nominal
Qh min: Heating capacity minimal
Qh max: Heating capacity maximal
Pin nom: Power input at nominal heating capacity
Pin min: Power input at minimal heating capacity
Pin max: Power input at maximal heating capacity
COP nom: coefficient of performance at nominal heating capacity
Qc nom: cooling / heat extraction capacity at nominal heating capacity
Qc min: cooling / heat extraction at minimal heating capacity
Qc max: cooling / heat extraction at maximal heating capacity
I nom: Current at nominal heating capacity
EER: energy efficiency ratio at nominal cooling capacity

Operating limits

°C

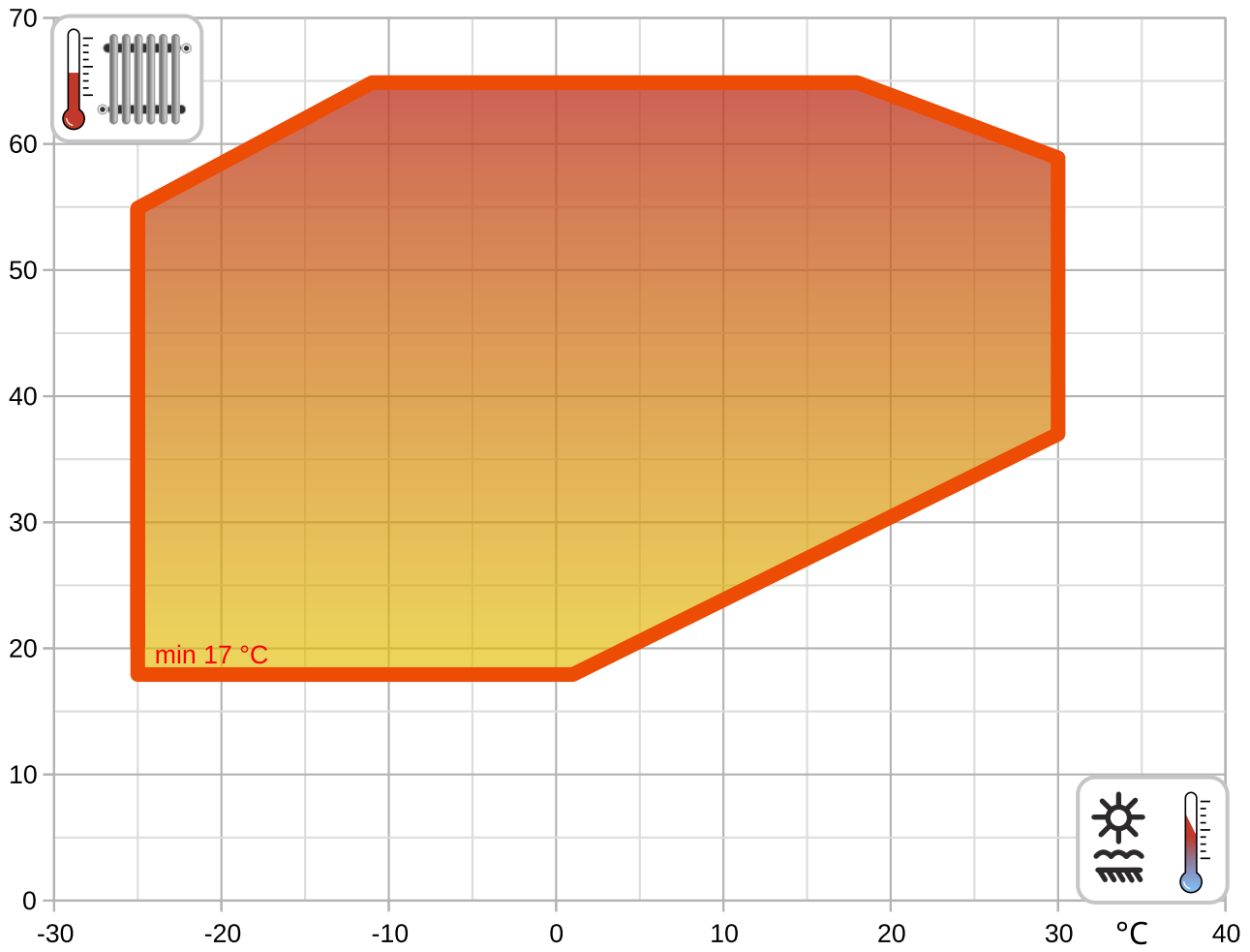

°C

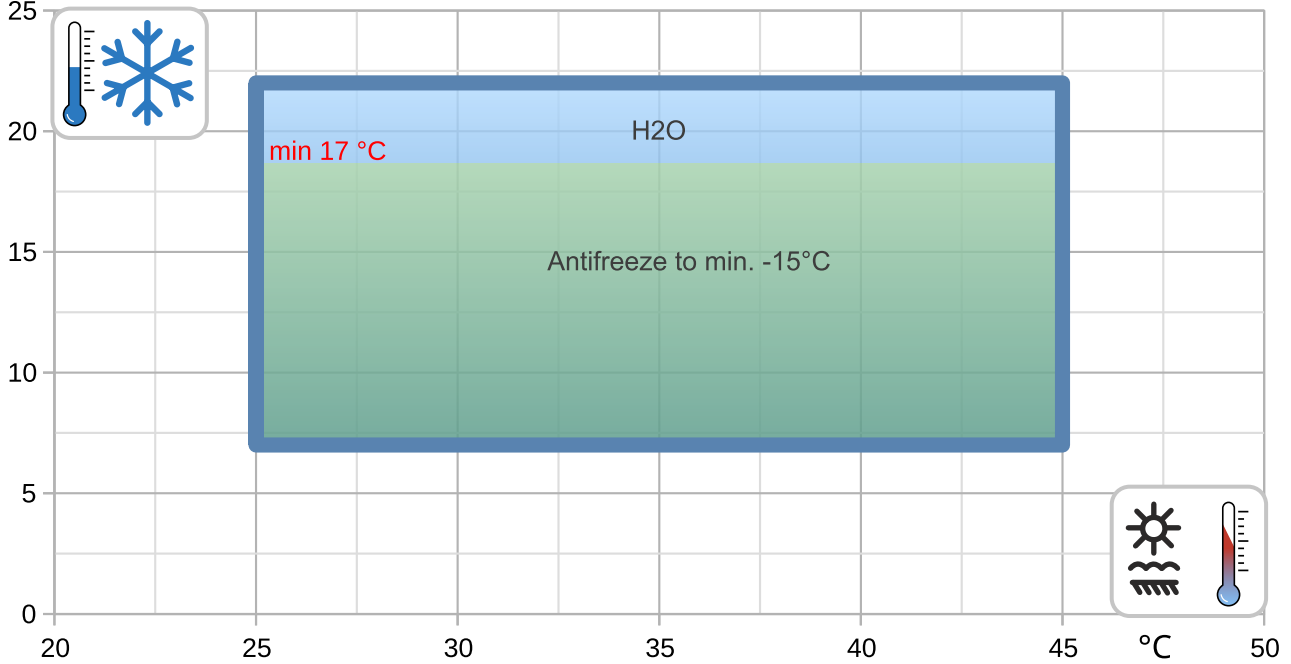

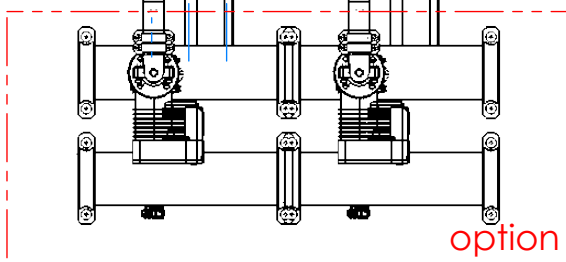
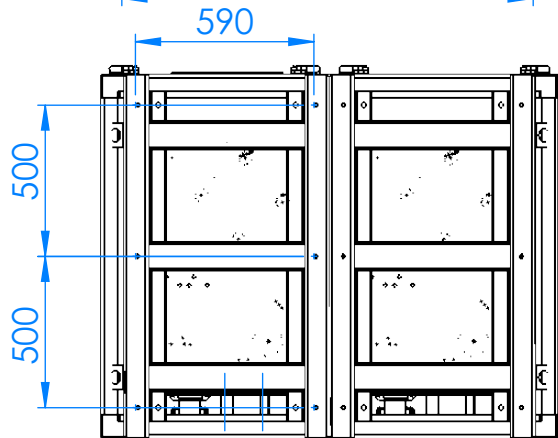
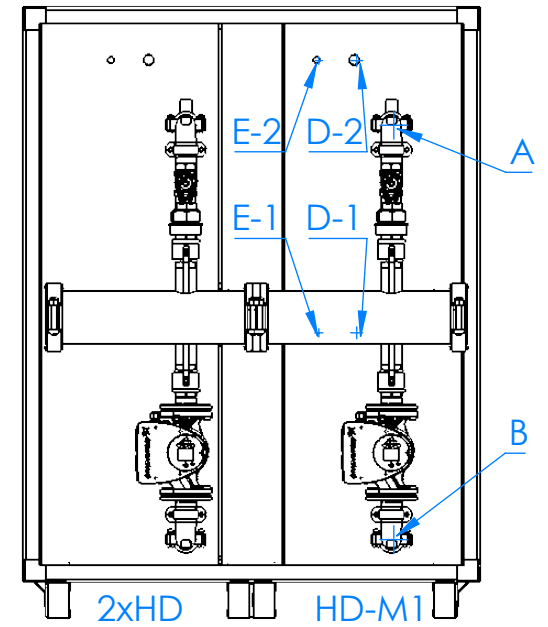
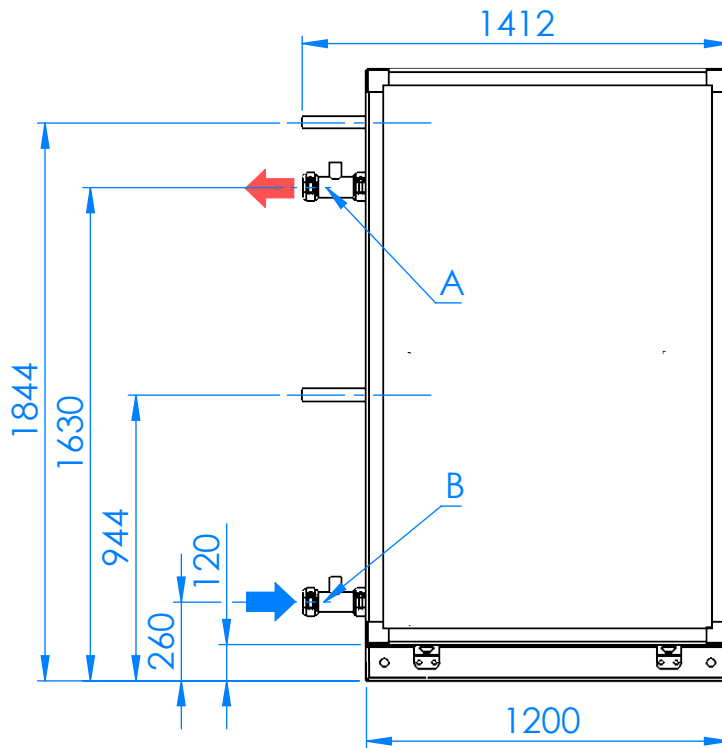
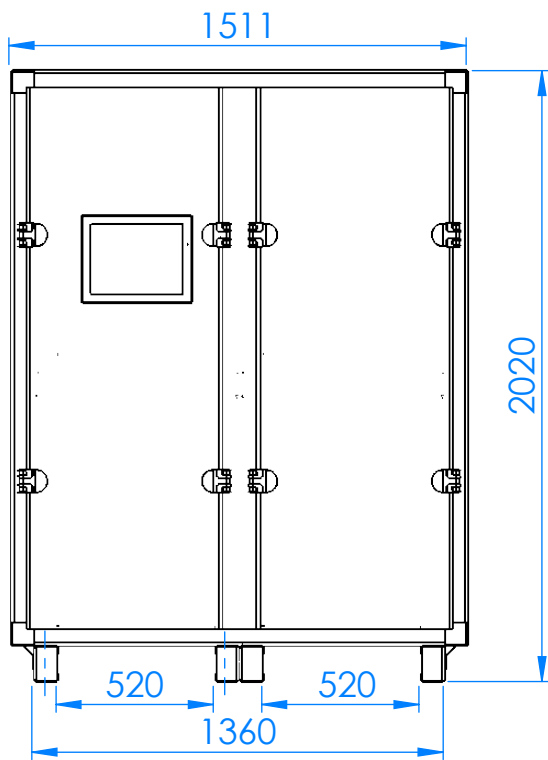

option

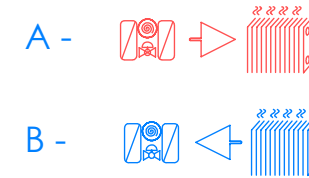
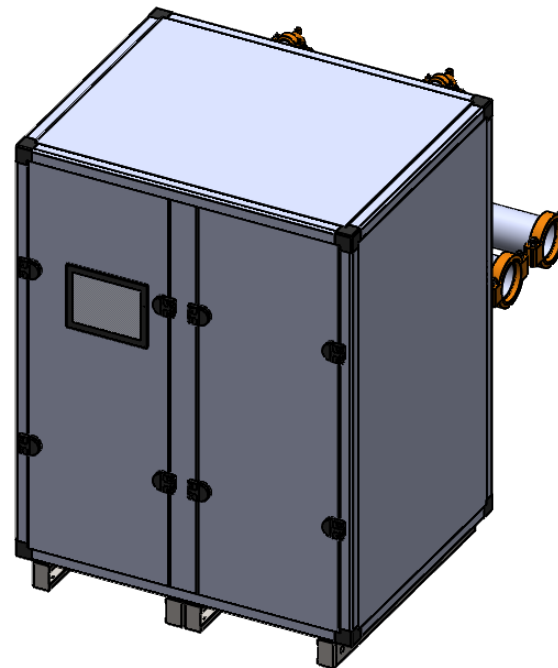

D (1,2) - SPLIT - FRIGO GAS
(Modul 1 - 2)

E (1,2) - SPLIT - FRIGO LIQUID
(Modul 1-2)

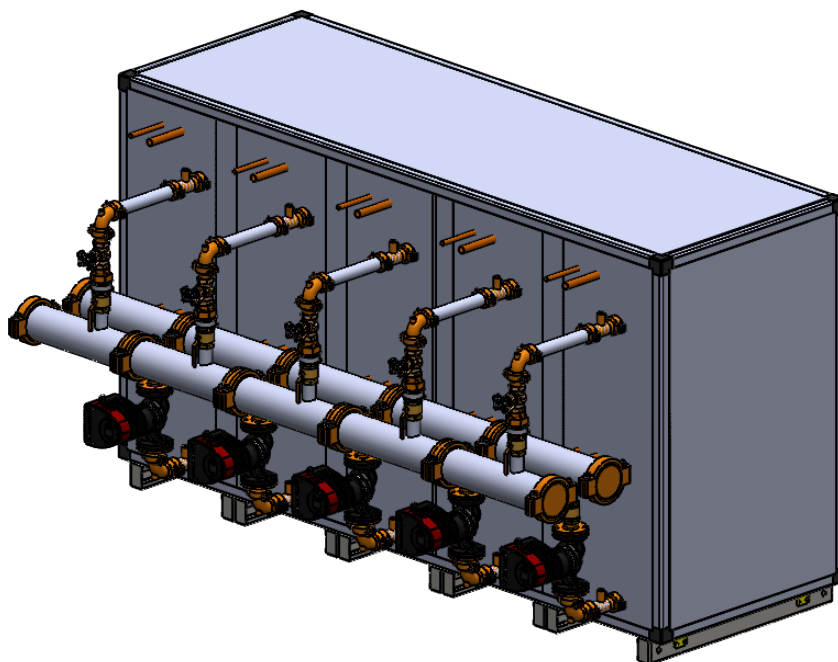
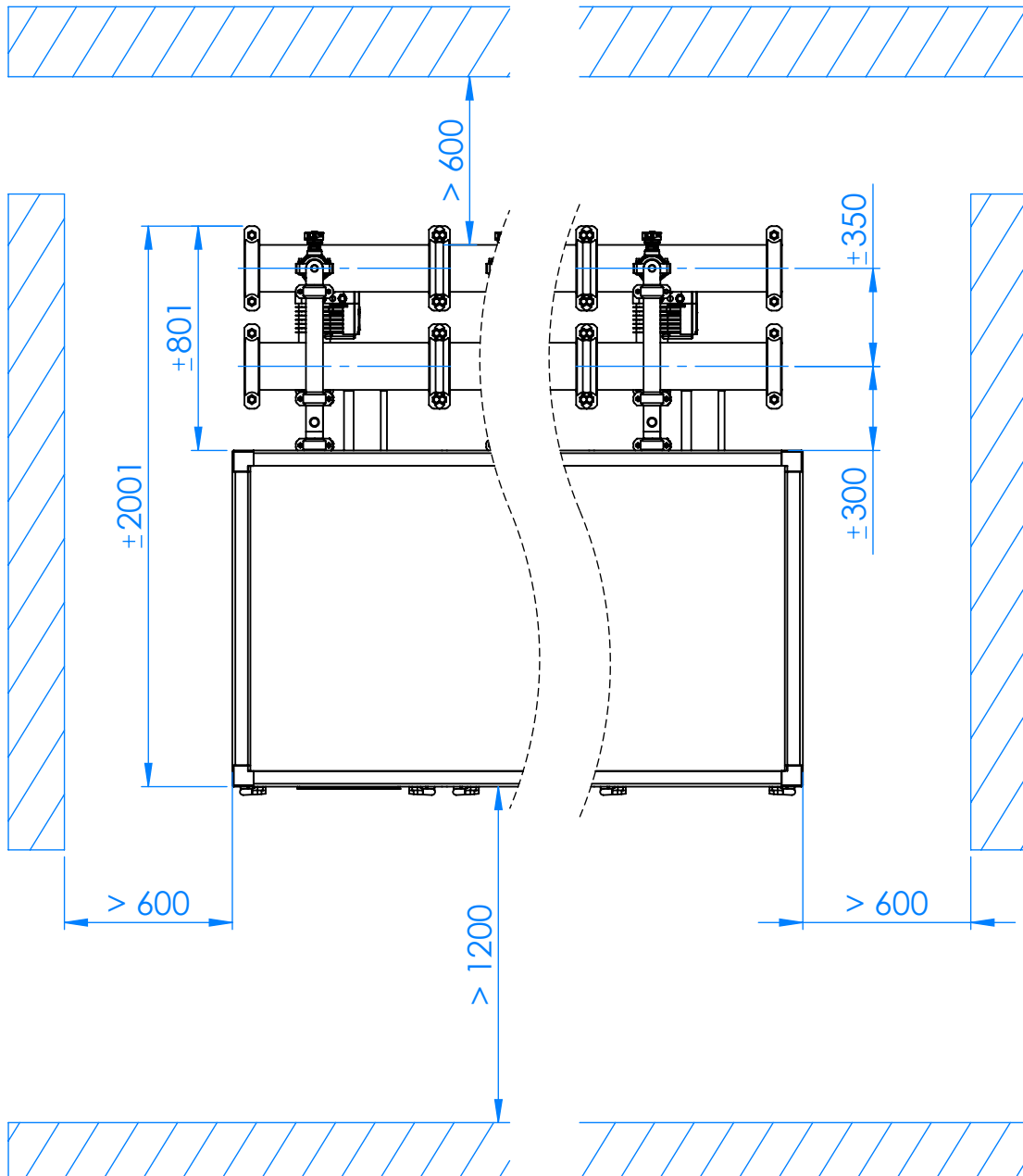

WAMAK AW 200 EVI HeavyDuty 2L2 - Split unit variant: VOV900X2-FRAME

Number of units needed

2



Enclosure type: VOV900X2-FRAME			Evaporator	
Article	WAVV2X90		Type	Cu-coil /Al-fin "
Basic dimensions	Height [mm]	1400	Port size	4 x (7/8" - 1.3/8") "
	Width [mm]	1500	Heat transfer medium	Air
	Length [mm]	2300	Volume flow - Air [m3/h]	15073 ~ 60290
Weight [kg]	430		Internal pressure drop - Air [kPa]	4 x 0.061
Colour	Inox		Temperature difference - Air	7 K
Enclosure IP Class	IP44		Expansion valve	EEV
Fan	800 mm			
Number of fans	2		Fan mounting position	Vertical axis
Fan motor type	EC		Fan type	Axial
Fan nominal current [A]	1.35		Fan power supply [V/Hz]	3~ 400/50
Minimal fan power input [Watt]	81		Maximal fan power input [Watt]	802

Acoustic power Lw

75.8 dB(A)

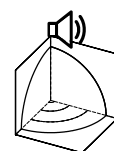
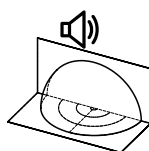
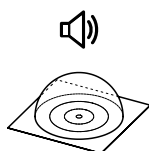

Distance [m]	1				5				10				15			
	1	5	10	15	1	5	10	15	1	5	10	15	1	5	10	15
Acoustic pressure Lp [dB(A)]	70.8	56.8	50.8	47.3	73.8	59.8	53.8	50.3	67.8	53.8	47.8	44.3				

EC Fan 800mm

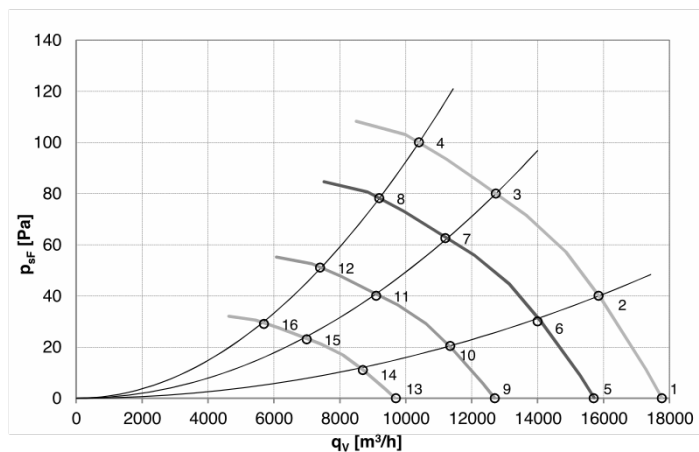

	U	f	n	qv	Pst	Pe	I	LwA out	Ta max
	[V]	[Hz]	[RPM]	[m³/h]	[Pa]	[W]	[A]	[dB (A)]	[°C]
1	400	50	735	17770	0	503	0,85	70	60
2	400	50	735	15850	40	612	1,02	66	60
3	400	50	735	12730	80	735	1,18	65	60
4	400	50	735	10400	100	802	1,36	68	60
5	400	50	650	15700	0	348	0,68	67	60
6	400	50	650	14000	30	421	0,80	63	60
7	400	50	650	11200	63	510	0,92	62	60
8	400	50	650	9200	78	554	0,93	65	60
9	400	50	525	12700	0	183	0,38	63	60
10	400	50	525	11350	20	225	0,35	59	60
11	400	50	525	9100	40	265	0,53	58	60
12	400	50	525	7400	51	292	0,57	61	60
13	400	50	400	9700	0	81	0,21	57	60
14	400	50	400	8700	11	97	0,24	53	60
15	400	50	400	7000	23	117	0,27	52	60
16	400	50	400	5700	29	128	0,28	55	60

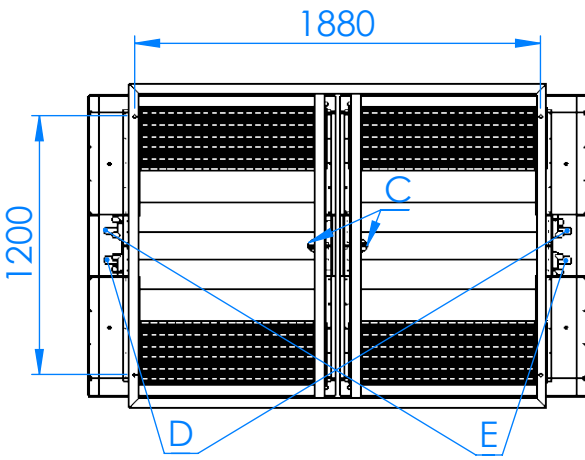
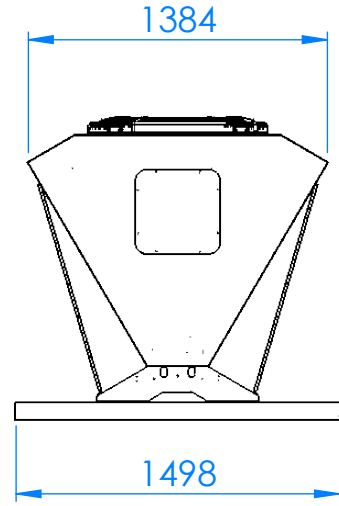
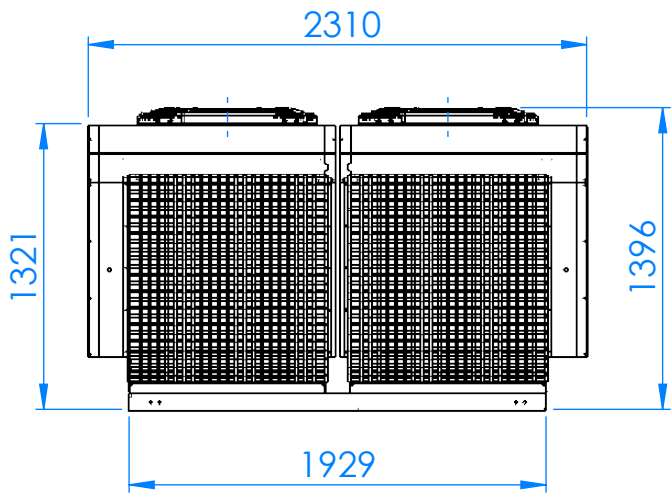

D - FRIGO GAS
E - FRIGO LIQUID
C - CONDENS

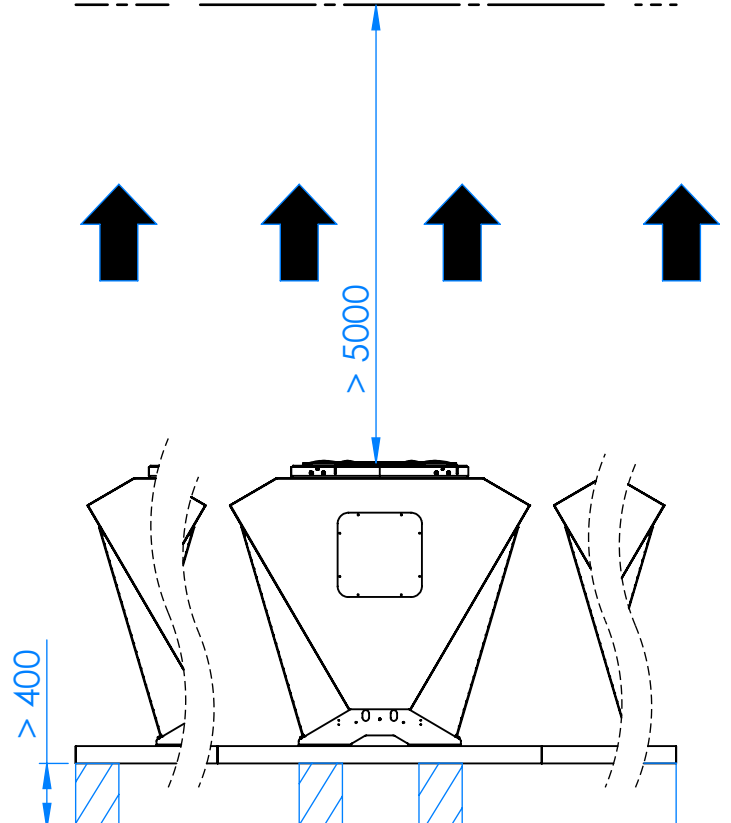
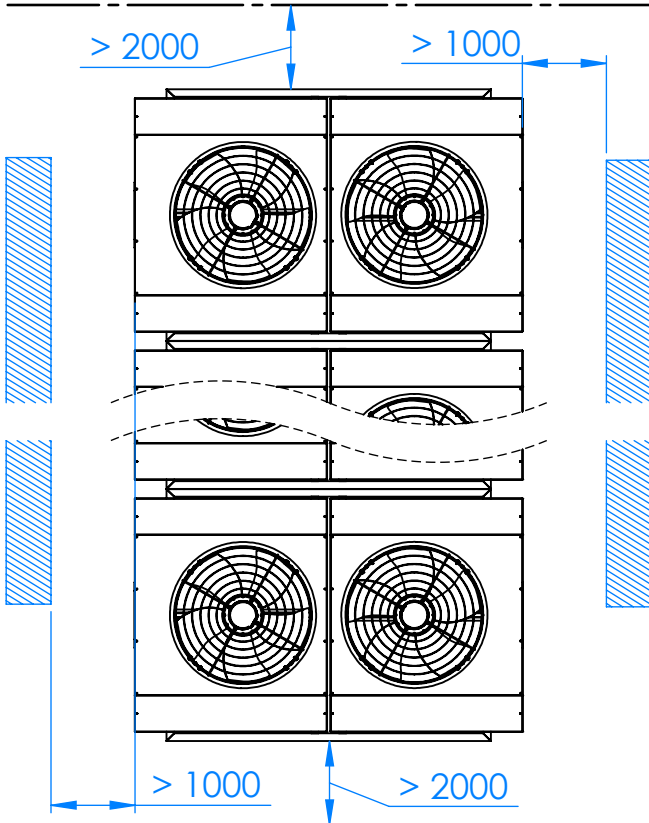
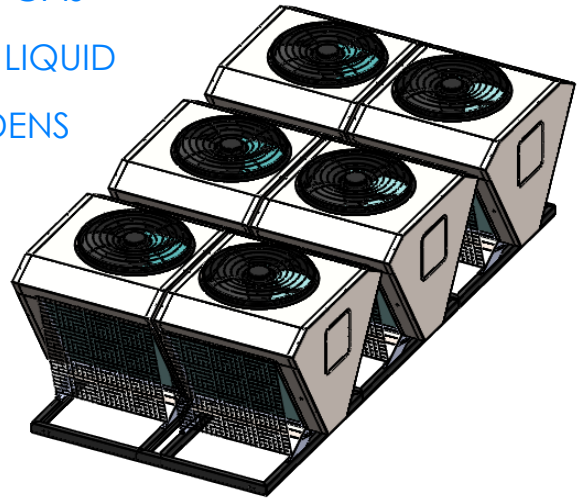

WAMAK AW 200 EVI HeavyDuty 2L2 - Split unit variant: VOII-1200-2LOW

Number of units needed

4

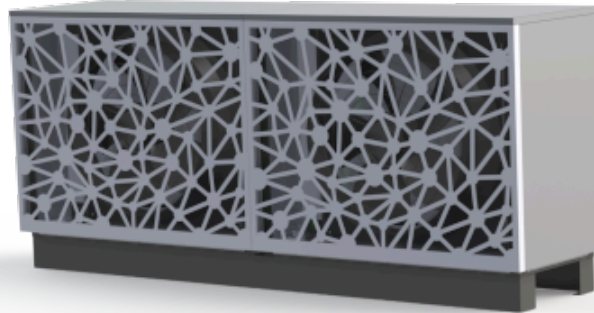

Enclosure type: VOII-1200-2LOW			Evaporator	
Article	WAVII12L		Type	Cu-coil /Al-fin "
Basic dimensions	Height [mm]	1240	Port size	4 x (7/8" - 1.3/8") "
	Width [mm]	2850	Heat transfer medium	Air
	Length [mm]	710	Volume flow - Air [m3/h]	15073 ~ 60290
Weight [kg]	300		Internal pressure drop - Air [kPa]	4 x 0.061
Colour	Gray		Temperature difference - Air	7 K
Enclosure IP Class	IP44		Expansion valve	EEV
Fan	800 mm			
Number of fans	2		Fan mounting position	Horizontal axis
Fan motor type	EC		Fan type	Axial
Fan nominal current [A]	1.35		Fan power supply [V/Hz]	3~ 400/50
Minimal fan power input [Watt]	81		Maximal fan power input [Watt]	802

Acoustic power Lw

71.3 dB(A)

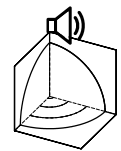
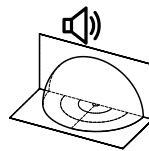
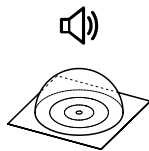

Distance [m]	1				5				10				15			
	1	5	10	15	1	5	10	15	1	5	10	15	1	5	10	15
Acoustic pressure Lp [dB(A)]	66.3	52.3	46.3	42.8	69.3	55.3	49.3	45.8	63.3	49.3	43.3	39.8				

EC Fan 800mm

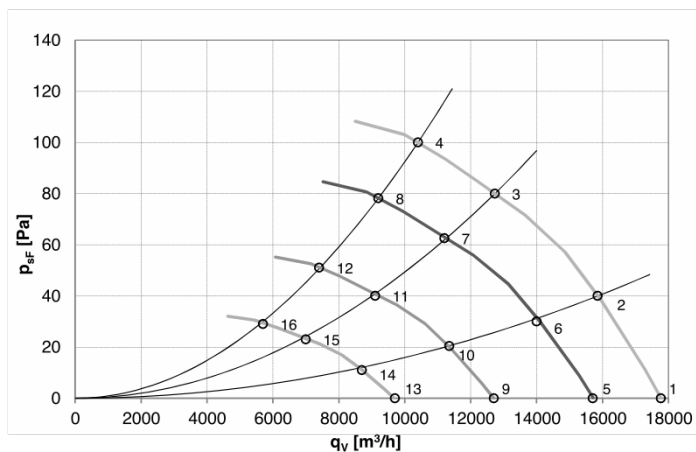

	U	f	n	qv	Pst	Pe	I	LwA out	Ta max
	[V]	[Hz]	[RPM]	[m³/h]	[Pa]	[W]	[A]	[dB (A)]	[°C]
1	400	50	735	17770	0	503	0,85	70	60
2	400	50	735	15850	40	612	1,02	66	60
3	400	50	735	12730	80	735	1,18	65	60
4	400	50	735	10400	100	802	1,36	68	60
5	400	50	650	15700	0	348	0,68	67	60
6	400	50	650	14000	30	421	0,80	63	60
7	400	50	650	11200	63	510	0,92	62	60
8	400	50	650	9200	78	554	0,93	65	60
9	400	50	525	12700	0	183	0,38	63	60
10	400	50	525	11350	20	225	0,35	59	60
11	400	50	525	9100	40	265	0,53	58	60
12	400	50	525	7400	51	292	0,57	61	60
13	400	50	400	9700	0	81	0,21	57	60
14	400	50	400	8700	11	97	0,24	53	60
15	400	50	400	7000	23	117	0,27	52	60
16	400	50	400	5700	29	128	0,28	55	60

WAMAK AW 200 EVI HeavyDuty 2L2 - Split unit variant: VOII-1200-2HIGH

Number of units needed

4

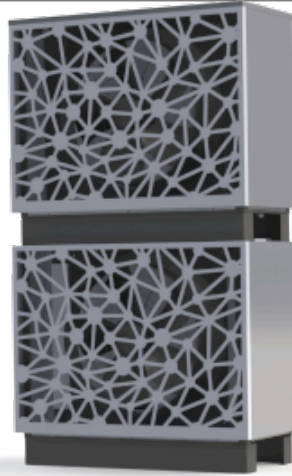

Enclosure type: VOII-1200-2HIGH			Evaporator	
Article	WAVII12H		Type	Cu-coil /Al-fin "
Basic dimensions	Height [mm]	2450	Port size	4 x (7/8" - 1.3/8") "
	Width [mm]	1420	Heat transfer medium	Air
	Length [mm]	710	Volume flow - Air [m3/h]	15073 ~ 60290
Weight [kg]	300		Internal pressure drop - Air [kPa]	4 x 0.061
Colour	Gray		Temperature difference - Air	7 K
Enclosure IP Class	IP44		Expansion valve	EEV
Fan	800 mm			
Number of fans	2		Fan mounting position	Horizontal axis
Fan motor type	EC		Fan type	Axial
Fan nominal current [A]	1.35		Fan power supply [V/Hz]	3~ 400/50
Minimal fan power input [Watt]	81		Maximal fan power input [Watt]	802

Acoustic power Lw

71.3 dB(A)

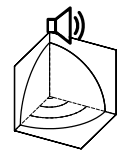
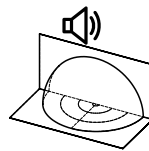
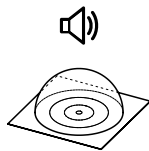

Distance [m]	1				5				10				15			
	1	5	10	15	1	5	10	15	1	5	10	15	1	5	10	15
Acoustic pressure Lp [dB(A)]	66.3	52.3	46.3	42.8	69.3	55.3	49.3	45.8	63.3	49.3	43.3	39.8				

EC Fan 800mm

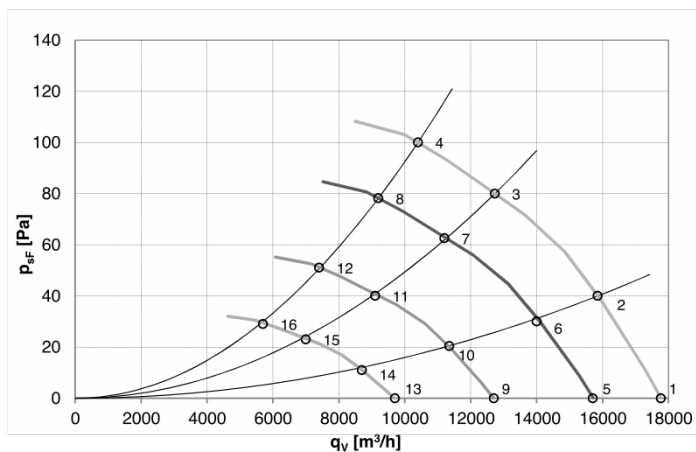

	U	f	n	qv	PstF	Pe	I	LwA out	Ta max
	[V]	[Hz]	[RPM]	[m³/h]	[Pa]	[W]	[A]	[dB (A)]	[°C]
1	400	50	735	17770	0	503	0,85	70	60
2	400	50	735	15850	40	612	1,02	66	60
3	400	50	735	12730	80	735	1,18	65	60
4	400	50	735	10400	100	802	1,36	68	60
5	400	50	650	15700	0	348	0,68	67	60
6	400	50	650	14000	30	421	0,80	63	60
7	400	50	650	11200	63	510	0,92	62	60
8	400	50	650	9200	78	554	0,93	65	60
9	400	50	525	12700	0	183	0,38	63	60
10	400	50	525	11350	20	225	0,35	59	60
11	400	50	525	9100	40	265	0,53	58	60
12	400	50	525	7400	51	292	0,57	61	60
13	400	50	400	9700	0	81	0,21	57	60
14	400	50	400	8700	11	97	0,24	53	60
15	400	50	400	7000	23	117	0,27	52	60
16	400	50	400	5700	29	128	0,28	55	60

WAMAK AW 200 EVI HeavyDuty 2L2

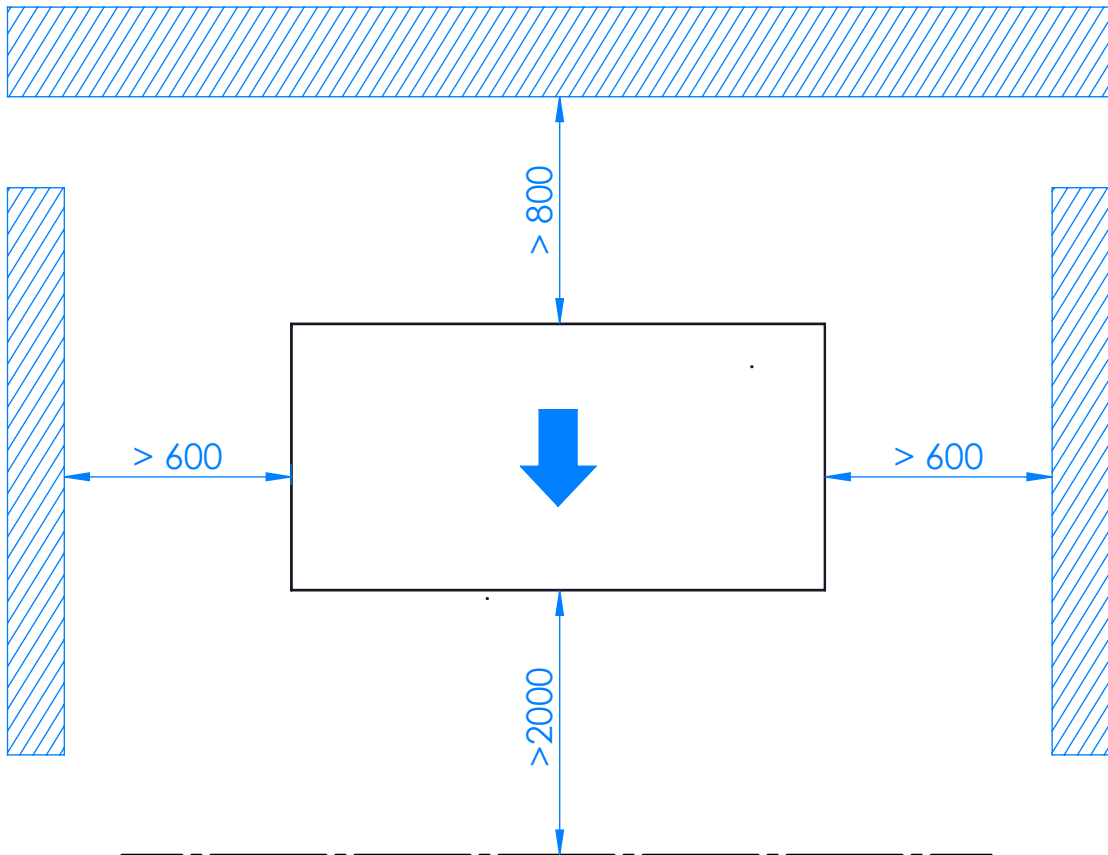
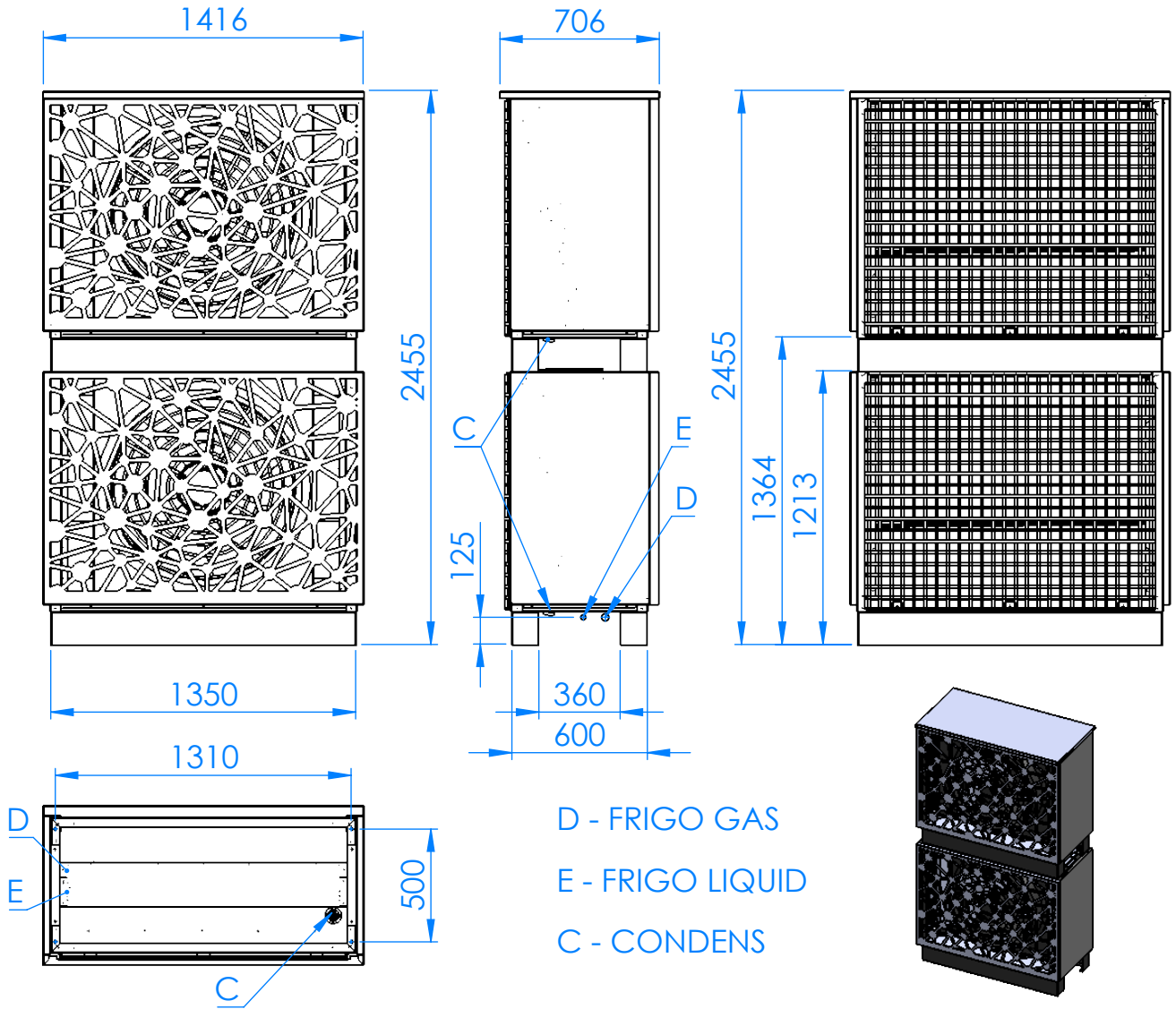

WAMAK AW 200 EVI HeavyDuty 2L2 - Split unit variant: VOII-1200-2LOW-DUCT

Number of units needed

4

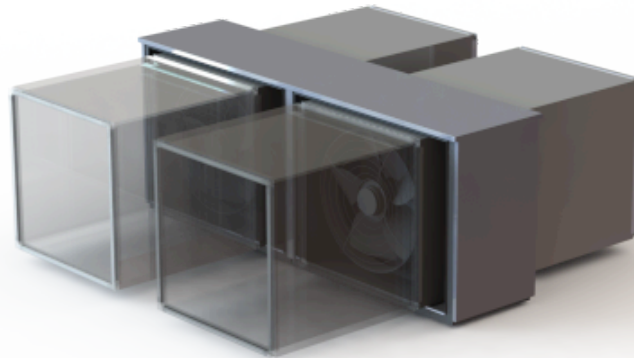

Enclosure type: VOII-1200-2LOW-DUCT			Evaporator	
Article	WAVID12L		Type	Cu-coil /Al-fin "
Basic dimensions	Height [mm]	1240	Port size	4 x (7/8" - 1.3/8") "
	Width [mm]	2850	Heat transfer medium	Air
	Length [mm]	710	Volume flow - Air [m3/h]	15073 ~ 60290
Weight [kg]	300		Internal pressure drop - Air [kPa]	4 x 0.061
Colour	Gray		Temperature difference - Air	7 K
Enclosure IP Class	IP44		Expansion valve	EEV
Fan	800 mm			
Number of fans	2		Fan mounting position	Horizontal axis
Fan motor type	EC		Fan type	Axial
Fan nominal current [A]	1.35		Fan power supply [V/Hz]	3~ 400/50
Minimal fan power input [Watt]	81		Maximal fan power input [Watt]	802

Acoustic power Lw

71.3 dB(A)

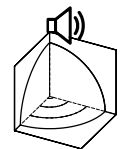
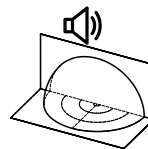
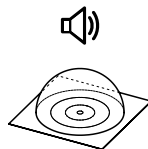

Distance [m]	1				5				10				15			
	1	5	10	15	1	5	10	15	1	5	10	15	1	5	10	15
Acoustic pressure Lp [dB(A)]	66.3	52.3	46.3	42.8	69.3	55.3	49.3	45.8	63.3	49.3	43.3	39.8				

EC Fan 800mm

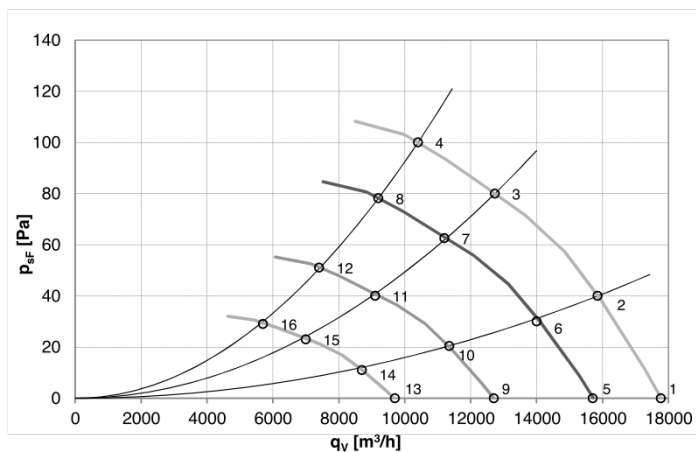

	U	f	n	qv	P _{sF}	P _e	I	L _{wA out}	T _{a max}
	[V]	[Hz]	[RPM]	[m³/h]	[Pa]	[W]	[A]	[dB (A)]	[°C]
1	400	50	735	17770	0	503	0,85	70	60
2	400	50	735	15850	40	612	1,02	66	60
3	400	50	735	12730	80	735	1,18	65	60
4	400	50	735	10400	100	802	1,36	68	60
5	400	50	650	15700	0	348	0,68	67	60
6	400	50	650	14000	30	421	0,80	63	60
7	400	50	650	11200	63	510	0,92	62	60
8	400	50	650	9200	78	554	0,93	65	60
9	400	50	525	12700	0	183	0,38	63	60
10	400	50	525	11350	20	225	0,35	59	60
11	400	50	525	9100	40	265	0,53	58	60
12	400	50	525	7400	51	292	0,57	61	60
13	400	50	400	9700	0	81	0,21	57	60
14	400	50	400	8700	11	97	0,24	53	60
15	400	50	400	7000	23	117	0,27	52	60
16	400	50	400	5700	29	128	0,28	55	60

WAMAK AW 200 EVI HeavyDuty 2L2 - Split unit variant: VOII-1200-2HIGH-DUCT

Number of units needed

4

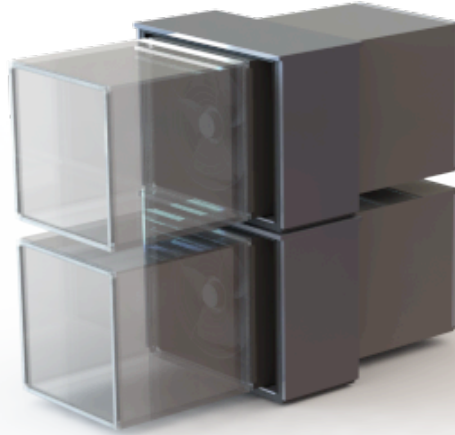

Enclosure type: VOII-1200-2HIGH-DUCT			Evaporator	
Article	WAVID12H		Type	Cu-coil /Al-fin "
Basic dimensions	Height [mm]	2450	Port size	4 x (7/8" - 1.3/8") "
	Width [mm]	1420	Heat transfer medium	Air
	Length [mm]	710	Volume flow - Air [m3/h]	15073 ~ 60290
Weight [kg]	300		Internal pressure drop - Air [kPa]	4 x 0.061
Colour	Gray		Temperature difference - Air	7 K
Enclosure IP Class	IP44		Expansion valve	EEV
Fan	800 mm			
Number of fans	2		Fan mounting position	Horizontal axis
Fan motor type	EC		Fan type	Axial
Fan nominal current [A]	1.35		Fan power supply [V/Hz]	3~ 400/50
Minimal fan power input [Watt]	81		Maximal fan power input [Watt]	802

Acoustic power Lw

71.3 dB(A)

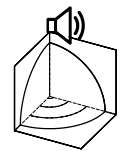
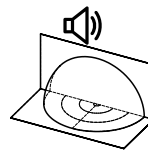
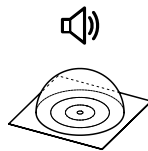

Distance [m]	1				5				10				15			
	1	5	10	15	1	5	10	15	1	5	10	15	1	5	10	15
Acoustic pressure Lp [dB(A)]	66.3	52.3	46.3	42.8	69.3	55.3	49.3	45.8	63.3	49.3	43.3	39.8				

EC Fan 800mm

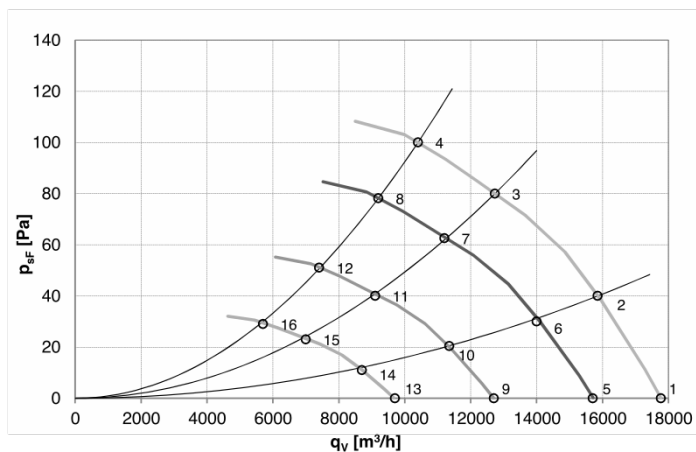

	U	f	n	qv	P _{sF}	P _e	I	L _{wA out}	T _{a max}
	[V]	[Hz]	[RPM]	[m³/h]	[Pa]	[W]	[A]	[dB (A)]	[°C]
1	400	50	735	17770	0	503	0,85	70	60
2	400	50	735	15850	40	612	1,02	66	60
3	400	50	735	12730	80	735	1,18	65	60
4	400	50	735	10400	100	802	1,36	68	60
5	400	50	650	15700	0	348	0,68	67	60
6	400	50	650	14000	30	421	0,80	63	60
7	400	50	650	11200	63	510	0,92	62	60
8	400	50	650	9200	78	554	0,93	65	60
9	400	50	525	12700	0	183	0,38	63	60
10	400	50	525	11350	20	225	0,35	59	60
11	400	50	525	9100	40	265	0,53	58	60
12	400	50	525	7400	51	292	0,57	61	60
13	400	50	400	9700	0	81	0,21	57	60
14	400	50	400	8700	11	97	0,24	53	60
15	400	50	400	7000	23	117	0,27	52	60
16	400	50	400	5700	29	128	0,28	55	60

WAMAK AW 200 EVI HeavyDuty 2L2

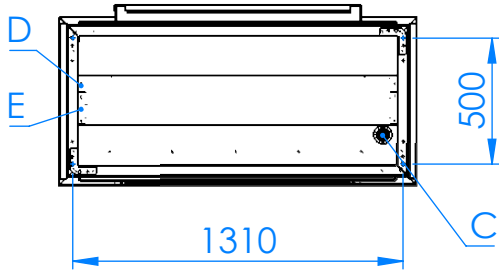
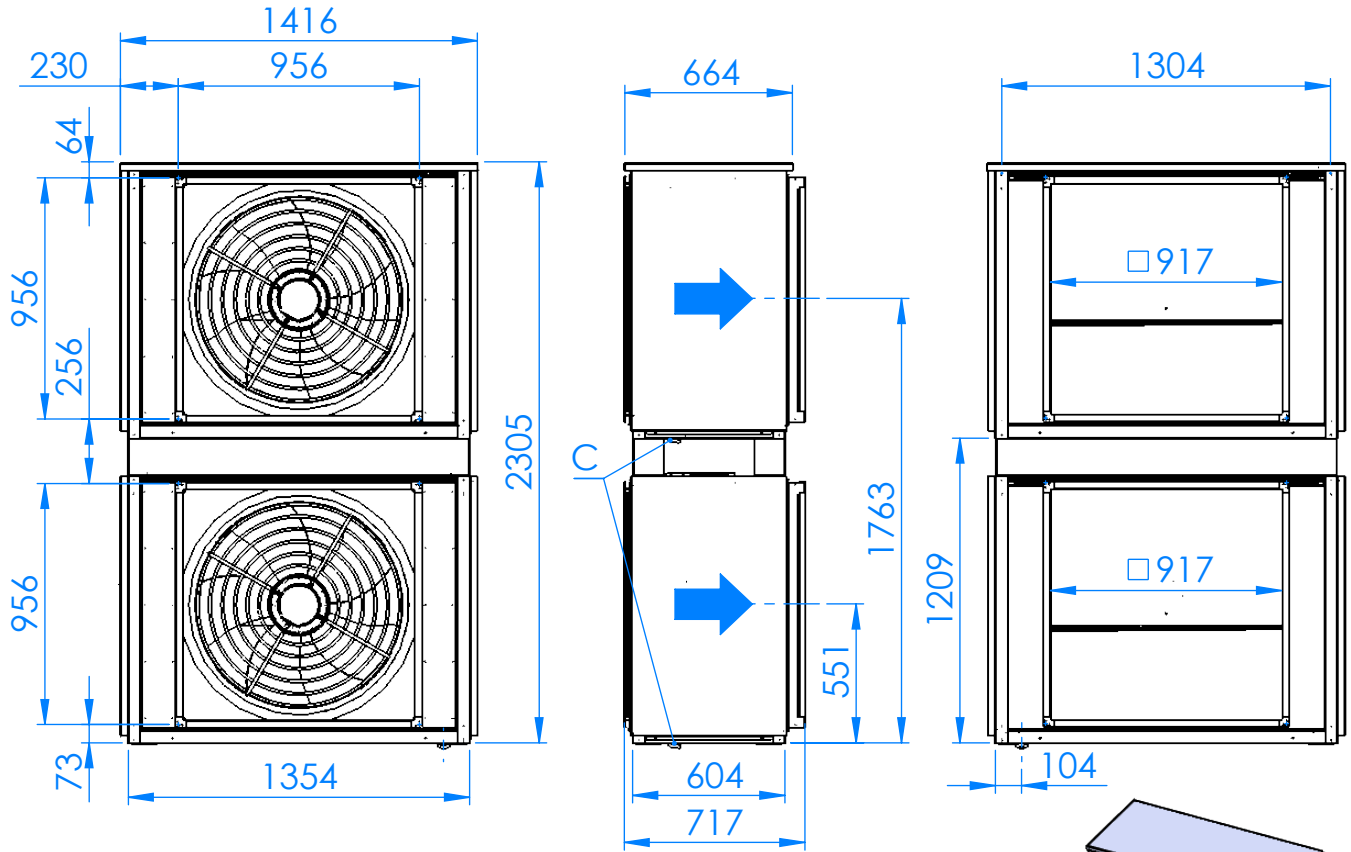

D - FRIGO GAS
 E - FRIGO LIQUID
 C - CONDENS

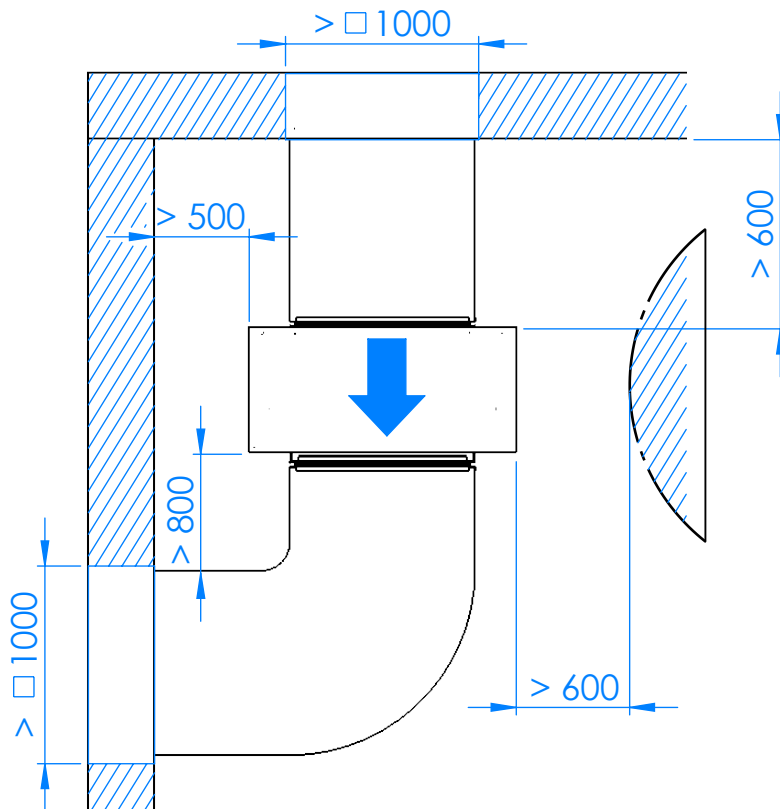
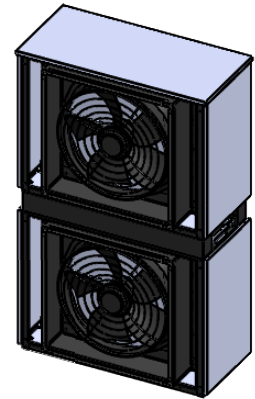

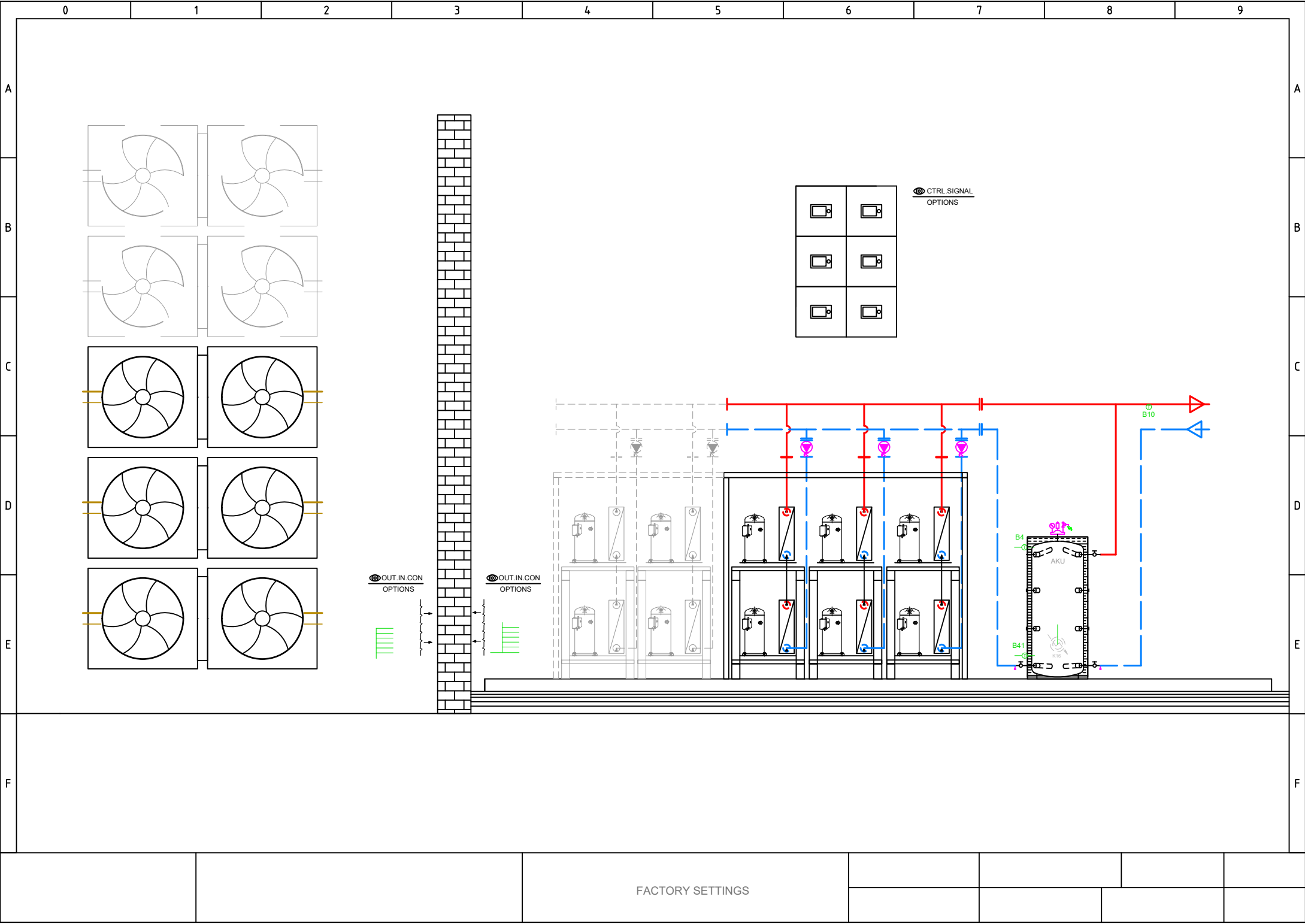

CTRL.SIGNAL
OPTIONS

OUT.IN.CON
OPTIONS

OUT.IN.CON
OPTIONS

FACTORY SETTINGS

Main power supply 230V / 50 Hz
Ground
Neutral conductor

- E10 High-pressure switch E10
- E11 Overload compressor 1 E11
- E14 Overload source E14
- E24 Flow switch consumers E24
- K82 Valve EVI K82

K40 Crankcase heater K40

- L Phase 230V
- K1 Compressor stage 1 K1
- Y22 Process revers valve Y22

Q9 Condenser pump Q9

X10	1	L
X10	1	PE
X10	1	N
X11	1	EX1
X11	1	EX2
X11	1	EX3
X11	1	EX4
X12	1	QX1
X12	1	N
X12	1	QX2
X12	1	QX2i
X12	1	N
X12	1	FX3
X12	1	QX3
X15	1	QX4
X15	1	QX4i
X15	1	N
X15	1	QX5
X15	1	N
X15	1	ZX6
X15	1	N
X86	1	GX1
X86	1	H3
X86	1	M
X86	1	H1
X86	1	G+
X86	1	M
X86	1	BSB



Total: max 6A
1 x QX...: max 2A

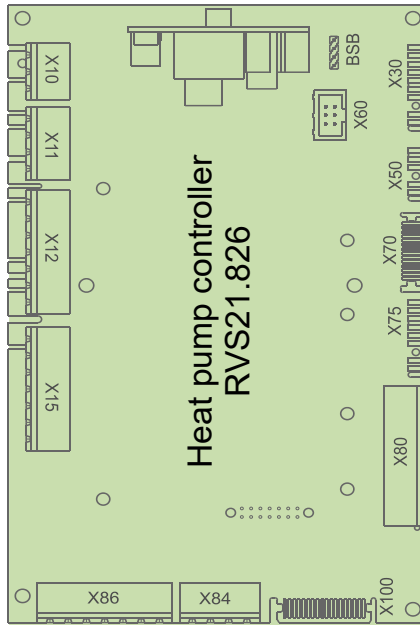

BSB
X30
X60
X50
X70

- Connection service tool (OCI700)
- Operating unit (HMI) AVS37.xxx
- Modbus clip-in OCI351.01
- Extension module AVS75.xxx
- LPB clip-in

D1
D2
D3
UX3
M
DI6
DI7
M

- D1 Digital output 1 Heating
- D2 Digital output 2 Cooling
- D3 Digital output 3 HP On/Off

- DI6 Digital input 6 Defrosting
- DI7 Digital input 7 Alarm

BX1
M
BX2
M
UX1
M
UX2
M

- B91 Source inlet sensor B91
- B84 Source outl sens B92/B84
- K19 Fan K19
- 0..10 V Signal
- Q9 Condenser pump Q9
- PWM Signal

BX3
M
BX4
M

- B71 HP return sensor B71
- B9 Outside sensor B9

Main power supply 230V / 50 Hz
Ground
Neutral conductor

K10 Alarm output K10

V81 EEV evaporator V81

X10	1	L
X10	1	PE
X10	1	N
X110	1	QX31
X110	1	QX32
X110	1	N
X110	1	QX33
X110	1	N
X110	1	ZX34
X110	1	N
X115	1	QX35
X115	1	QX35i
X115	1	N

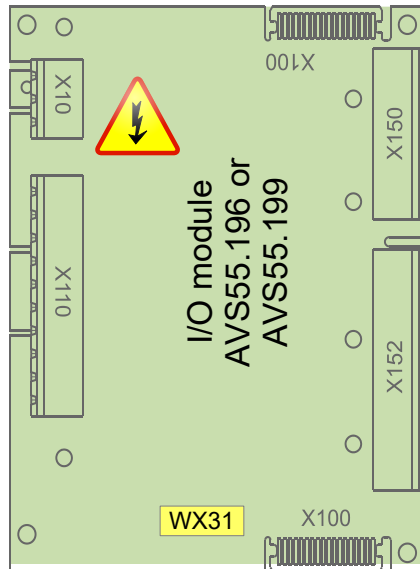

BSB
M
G+
H31
M
H32
GX1
H33
M
BX31
M
BX32
M
BX33
M
BX34
M

- 5 V/12 V for active sensors
- Flow measurement 10V
- Low pressure 0..10V
- 5 V/12 V for active sensors
- High pressure 0..10V
- B21 HP flow sensor B21
- B81 Hot-gas sensor B81
- B85 Suction gas sensor B85
- B83 Refrig sensor liquid B83

- AVS75.390
- AVS75.391
- AVS75.370

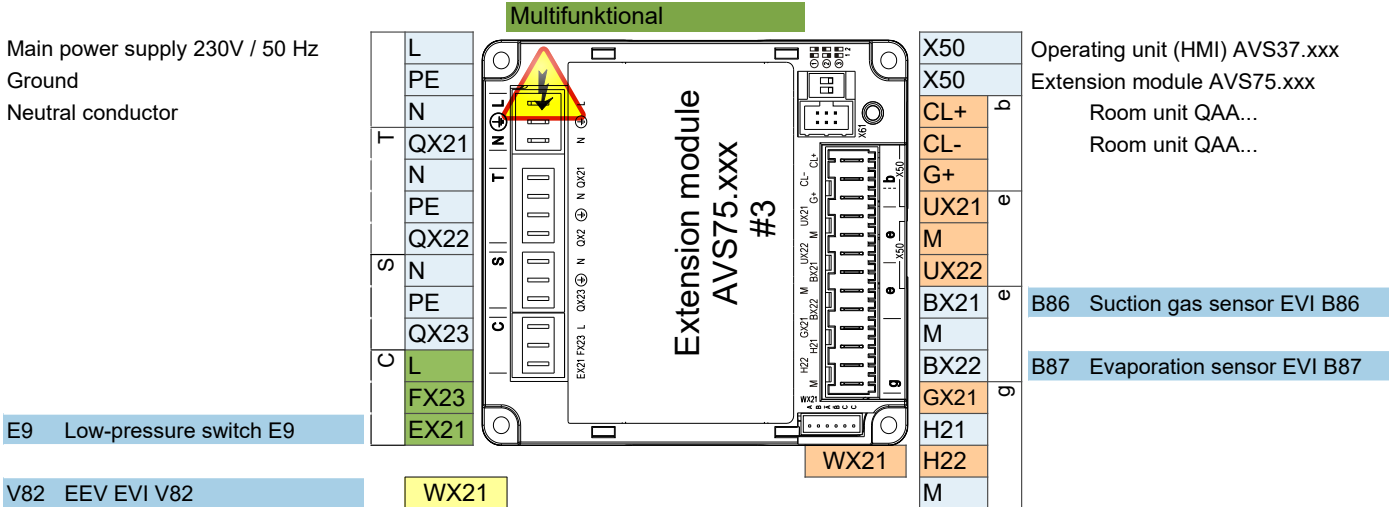
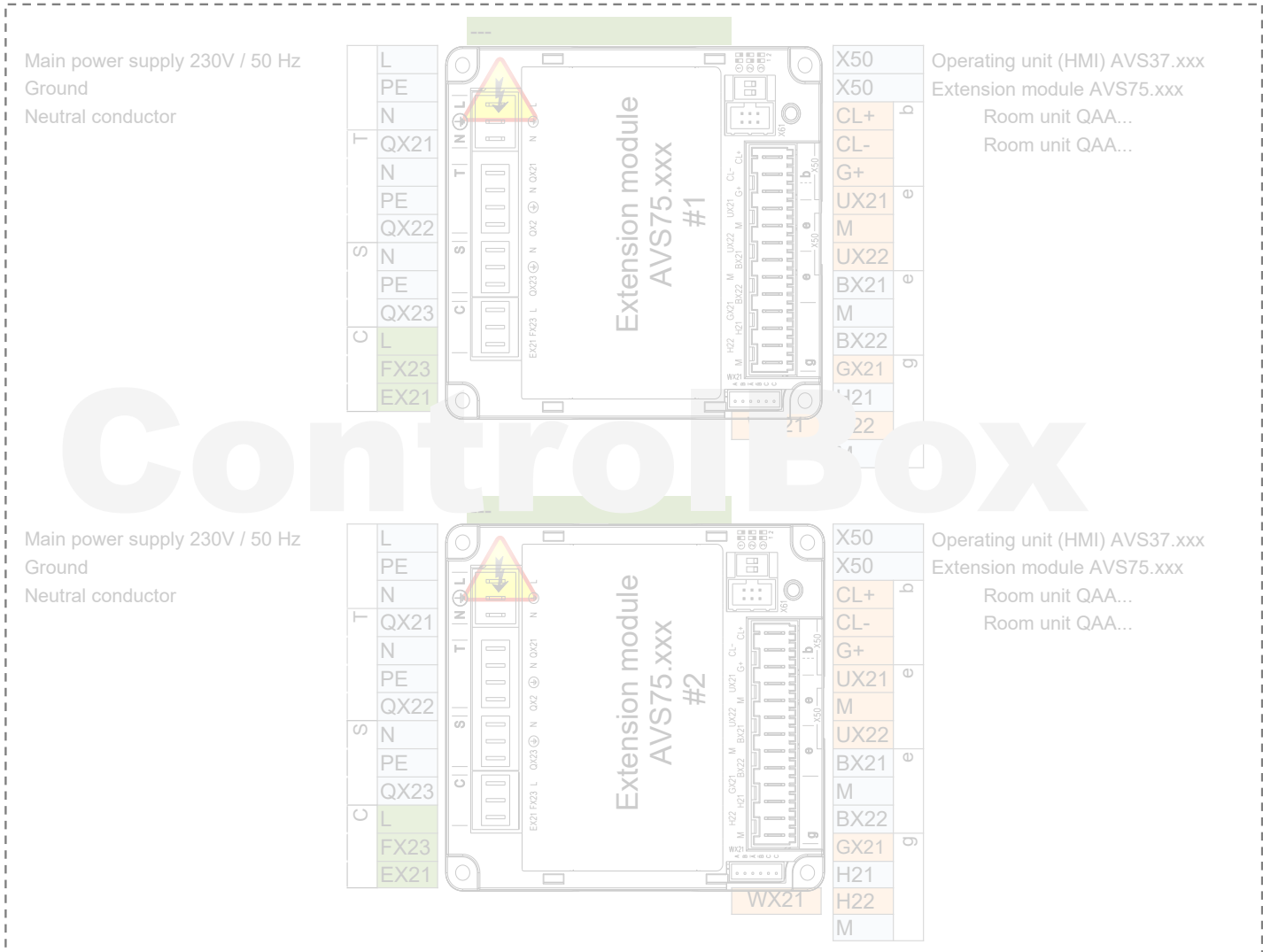

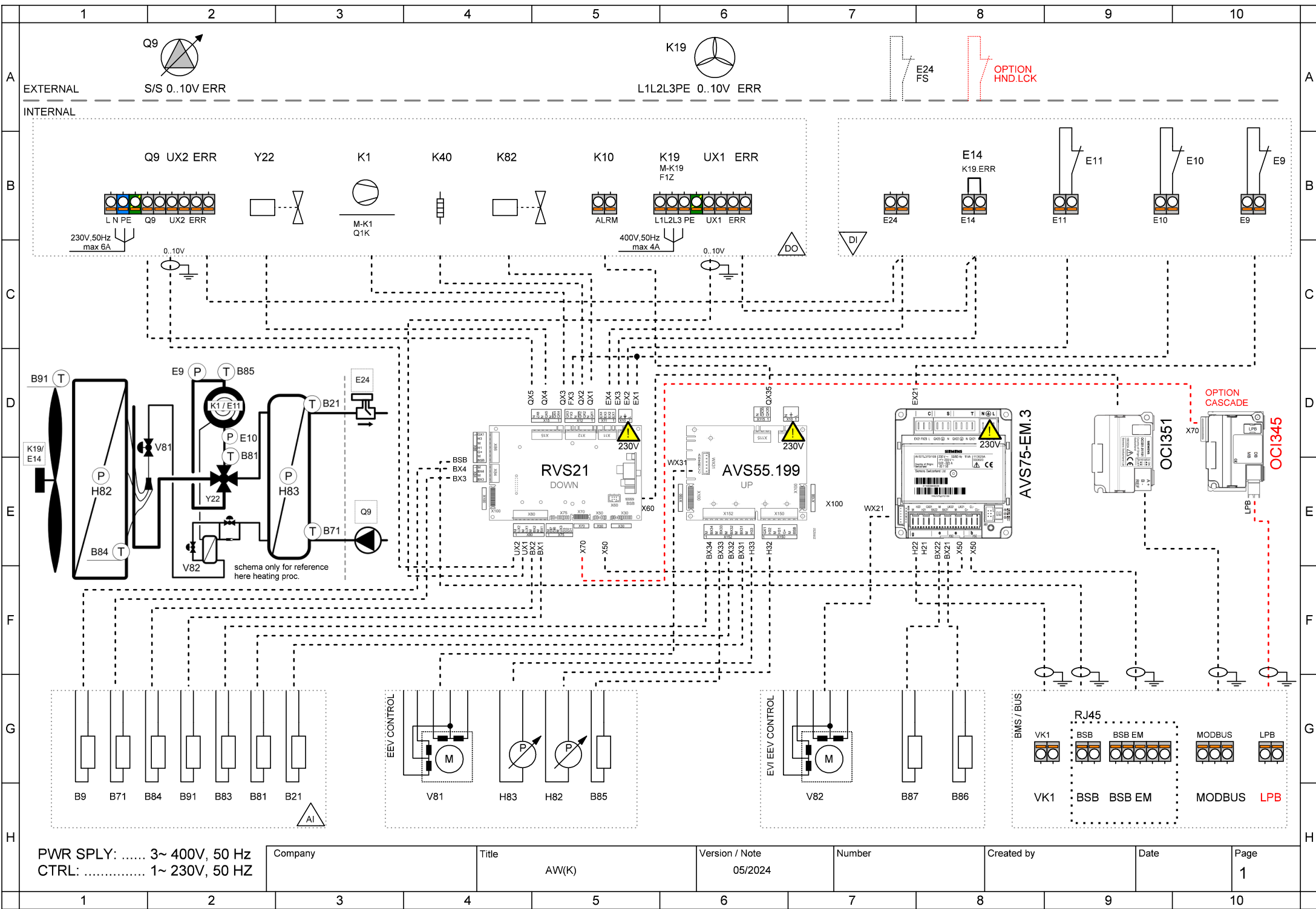

PWR SPLY: 3~ 400V, 50 Hz
 CTRL: 1~ 230V, 50 HZ

Company	Title	Version / Note	Number	Created by	Date	Page
	AW(K)	05/2024				1

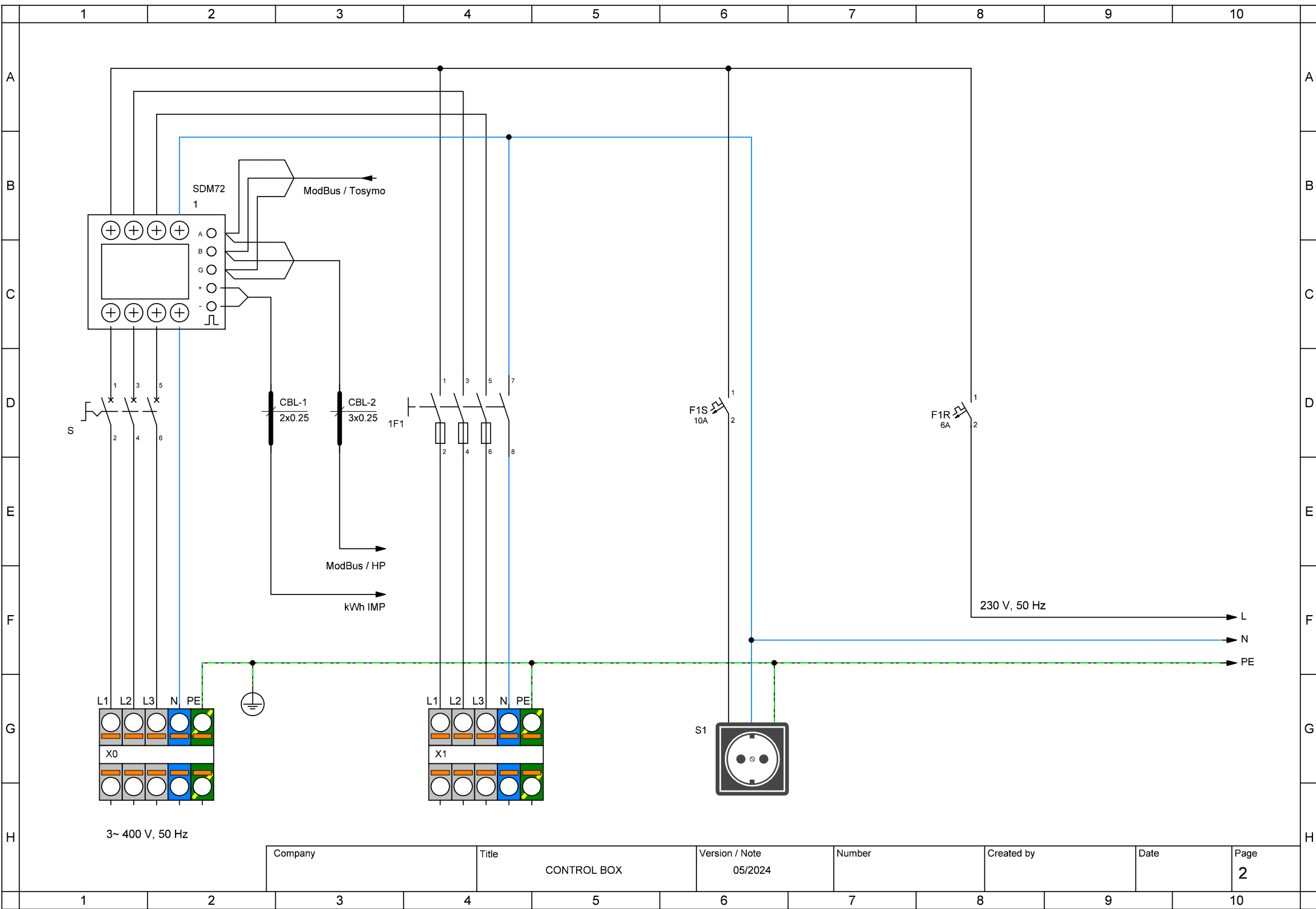

Company	Title	Version / Note	Number	Created by	Date	Page
	CONTROL BOX	05/2024				2

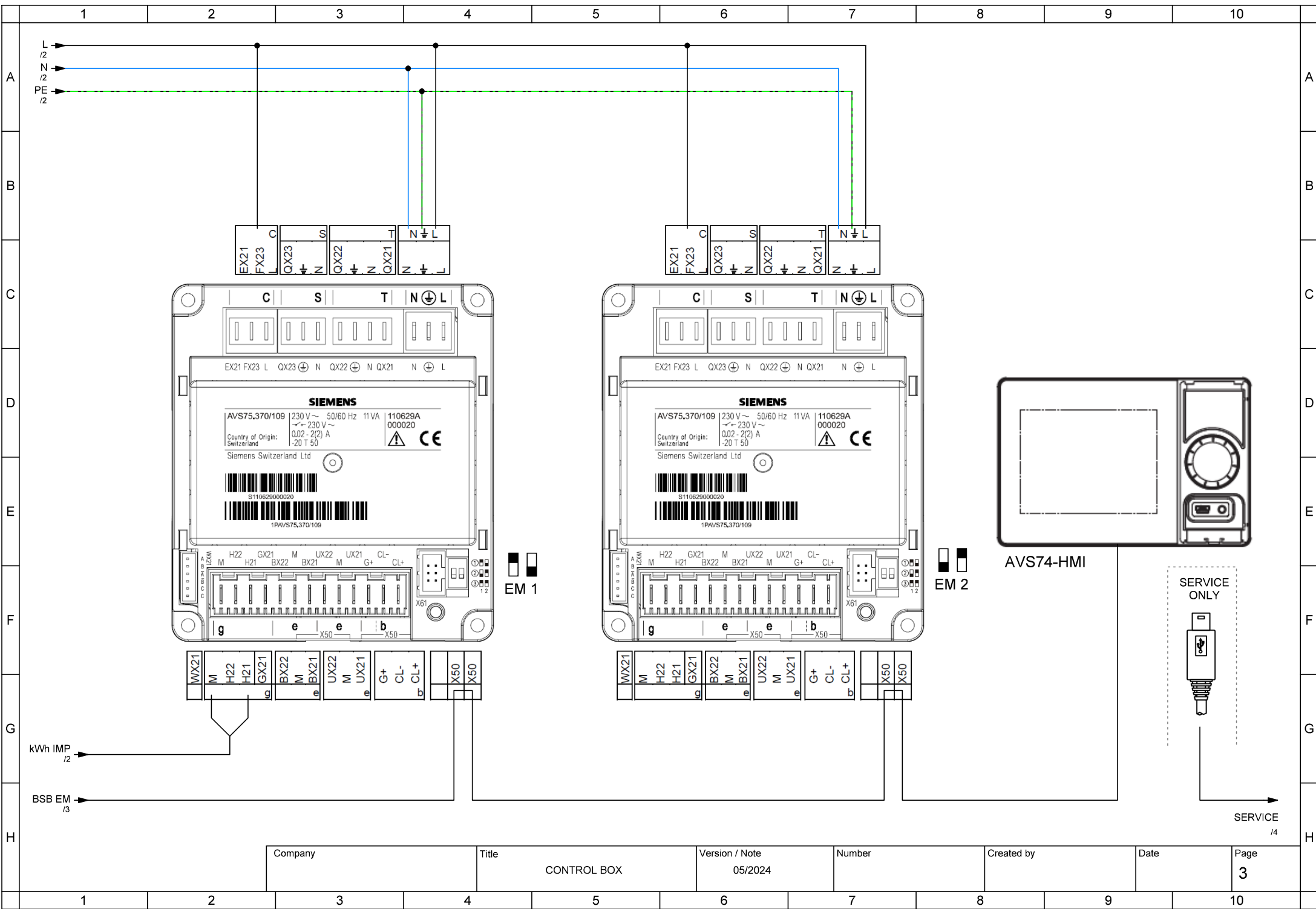

Company	Title	Version / Note	Number	Created by	Date	Page
	CONTROL BOX	05/2024				3

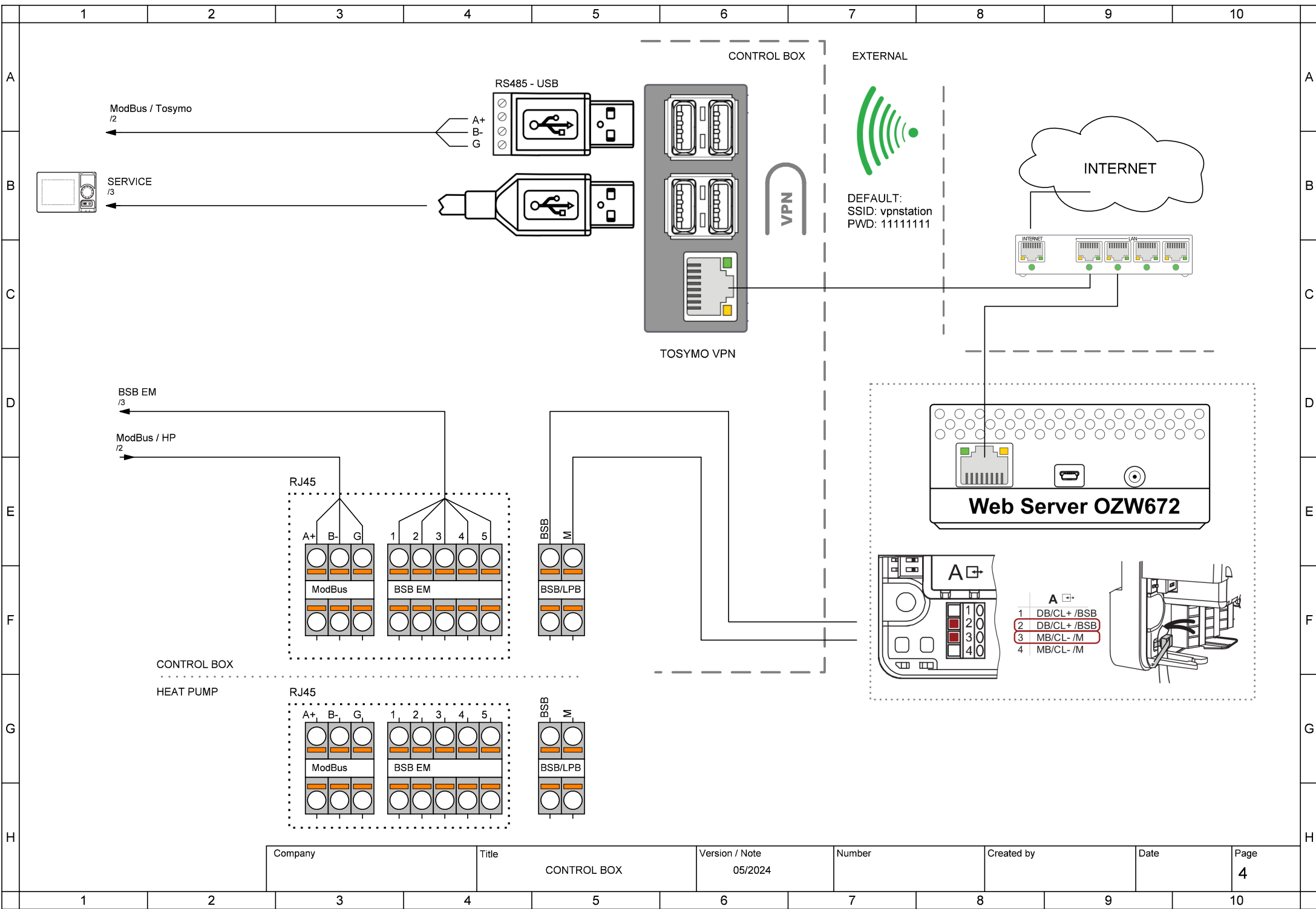

Company	Title	Version / Note	Number	Created by	Date	Page
	CONTROL BOX	05/2024				4

Control connection options

1 ControlBox

ControlBox, with two built-in extension modules, enables numerous options for application control on the consumer side behind the heat pump. For more, see the ControlBox schematic and the application diagrams sheet.

2 Fix flow temperature setpoint - On / Off dry (potential free) contact

2 wire shielded cable 2 x 0.5 mm² - Setpoint = 45°C (editable by param. 1859)

Connection terminal - see wiring diagram

3 Analog 0..10V flow temperature setpoint control

2 wire shielded cable 2 x 0.5 mm² - Setpoint: 0V = 16°C ~ 10V = 60°C (editable in parameter set)

Connection terminal - see wiring diagram

4 ModBus RTU communication command

3 wire shielded cable min. 3 x 0.25mm²

For ModBus mapping table contact technical support

5 MQTT IoT communication protocol

For more information contact technical support