

Základné údaje o výkone - WAMAK AWK 35 EVI

Vykurovanie - EN 14511		
Tepelný výkon [kW]	A7 / W35	38.0
	A2 / W35	32.3
	A-7 / W34	27.0
Elektrický príkon [kW]	A7 / W35	8.8
	A2 / W35	8.8
	A-7 / W34	8.6
Tepelná účinnosť [COP]	A7 / W35	4.31
	A2 / W35	3.67
	A-7 / W34	3.14
Sezónna tepelná účinnosť vykurovania - SCOP EN 14825		
Stredná klim. zóna / Nízka teplota [35°C]	SCOP	4.14
	η [%]	165.8
	Label	A+++
	Qhe [kWh]	14911.3
	Pdesignh [kW]	30.6
	Tbivalent [°C]	-7
Chladenie		
Chladiaci výkon - [kW]	A35 / W23-18	37.4
	A25 / W23-18	39.0
	A35 / W12-7	27.8
	A25 / W12-7	27.8
Sezónna účinnosť chladenia - SEER EN 14825		
[W 23 / 18°C]	SEER	4.39
	Qce [kWh]	16680.0
	η_c [%]	175.8
Zvuk EN 12102		
Zvuk - výkon - Lw	dB(A)	65.9
Zvuk - tlak - Lp	1 m dB(A)	57.9
	5 m dB(A)	43.9
	10 m dB(A)	37.9
Strojné a prevádzkové informácie		
Typ kompresoru (3~ 400/50)	SCROLL / 1 /	Zap/Vyp
Chladivo	R410A (GWP - 2088)	8.2 kg
Prevádzkové hraničné teploty vykurovania - (min / max) [°C]		25 / 65
Prevádzkové hraničné teploty zdroja - (min / max) [°C]		-22 / 40
Váha zariadenia		540 kg

Hlavné technické údaje - WAMAK AWK 35 EVI

Označenie krytovania		AWK-VOV900		Údaje strany odovzdania tepelnej energie		
Základné rozmery	Výška [mm]	1250		Prevádzkové hraničné teploty vykurovania	MAX [°C]	65
	Šírka [mm]	1380			MIN [°C]	25
	Dĺžka [mm]	1780		viac vid. diagram prevádzkových limitov		
Váha zariadenia [kg]	540		Kondenzátor	Pripojovacia dimenzia	2 "	
Farba krytovania	Nerez			Typ	BPHE	
IP trieda krytovania	IP44			Počet	1	
				Materiál	AISI 316	
Chladivový okruh				Maximálny prevádzkový tlak - chladivo [bar]	50	
Kompresor	Typ	Scroll		Maximálny prevádzkový tlak - Voda [bar]	6	
	Výkonové stupne	1		Testovací pretlak [bar]	70	
	Zap/Vyp			Teplonosné médium	Voda	
	Účinník Cosφ	0.55		Objemový prietok @ dT 5K (nom) - Voda [m3/h]	6.56	
	Odpor vynutia kompresora	0.83 Ohm		Vnútorná tlaková strata - Voda [kPa]	12	
Chladivo		R410A		Teplotný spád @ 35°C (nom)	5 K	
	Objem	8.2 kg		@ 55°C	8 K	
	GWP	2088		@ 65°C	10 K	
	Bezpečnostná trieda	A1				
Typ oleja v okruhu	POE RL32-3MAF			Údaje strany odberu obnoviteľnej energie		
	Objem oleja	3.38 L		Prevádzkové hraničné teploty zdroja	MIN [°C]	-22
Maximálny tlak chladiva [bar]		50			MAX [°C]	40
	PED trieda	2		viac vid. diagram prevádzkových limitov		
EVI - vstrek chladiva s ekonomizérom			Výparník	Typ	Cu-coil /Al-fin	
APS systém podchladenia chladiva				Počet	1	
Reverzibilný chod (chladenie)				Materiál	Cu/Al	
Reverzibilné odtavenie horúcimi parami				Maximálny prevádzkový tlak - chladivo [bar]	29	
Ochrana doskového výmenníka horúcimi parami HG-BYPASS			Teplonosné médium	Vzduch		
Údaje elektrického pripojenia			Objemový prietok - Vzduch [m3/h]	11650		
Elektro napájanie [#~ V/Hz]	3~ 400/50		Vnútorná tlaková strata - Vzduch [kPa]	0.027		
Prúd	nominálny [A]	21.23		Teplotný spád - Vzduch	7 K	
	maximálny [A]	32.50		Počet ventilátorov	1	
	štartovací [A]	49.7		Priemer ventilátora [mm]	800	
Softštartér	-					
Hlavný istič - charakteristika	C32					
Riadiaci systém						
Hlavný regulátor	SIEMENS	RVS 21 AVS 55.199				
Rozširovací modul	AVS75.3xx	AVS75.3xx	AVS75.372			
Bus Clip-In		LPB OCI345	Modbus OCI351			
Online pripojenie		Web server OZW672	ToSyMo			
Regulácia EEV	1 - EEV H/C					

*** s príslušenstvom

WAMAK AWK 35 EVI

ErP (EU) No 811/2013: Technické parametre vykurovacích zariadení s tepelným čerpadlom

Model	AWK 35 EVI
Tepelné čerpadlo vzduch-voda	áno
Tepelné čerpadlo soľanka-voda	nie
Tepelné čerpadlo voda-voda	nie
Nízkotepelné tepelné čerpadlo	nie
Vybavené prídavným ohrievačom	nie
Kombinované tepelné čerpadlo s ohrievačom	nie
Teplotné použitie	nízka teplota (35 °C - 30 °C)
Klimatická oblasť	priemerná

Položka	Symbol	Hodnota	mj	Položka	Symbol	Hodnota	mj
Menovitý tepelný výkon pri Tdesignh	Prated	30.6	kW	Sezónna energetická účinnosť vykurovania priestoru	η_s	165.8	%
Deklarovaný výkon vykurovania pri čiastočnom zaťažení pri vnútornej teplote 20 °C a vonkajšej teplote Tj				Deklarovaný súčiniteľ výkonu alebo pomer primárnej energie pre čiastočné zaťaženie pri vnútornej teplote 20 °C a vonkajšej teplote Tj			
Tj = -7 °C	Pdh	27.0	kW	Tj = -7 °C	COPd	3.14	-
Tj = +2 °C	Pdh	31.9	kW	Tj = +2 °C	COPd	4.0	-
Tj = +7 °C	Pdh	37.3	kW	Tj = +7 °C	COPd	5.1	-
Tj = +12 °C	Pdh	43.4	kW	Tj = +12 °C	COPd	6.7	-
Tj = bivalentná teplota	Pdh	26.5	kW	Tj = bivalentná teplota	COPd	3.0	-
Tj = hraničná prevádzková teplota	Pdh	19.2	kW	Tj = hraničná prevádzková teplota	COPd	2.2	-
Bivalentná teplota	Tbiv	-7	°C	Tj = hraničná prevádzková teplota	TOL	-22	°C
Spotreba energie v iných ako aktívnych režimoch				Medzná prevádzková teplota vykurovacej vody	WTOL	65	°C
Vypnuté	Poff	0.040	kW	Prídavný ohrievač			
Režim vypnutia termostatu	Pto	0.010	kW	Menovitý tepelný výkon	Psup	13.7	kW
Pohotovostný režim	Psb	0.010	kW	Typ príkonu energie	elektrická		
Režim ohrevu kľukovej skrine	Pck	0.050	kW				
Ostatné položky							
Regulácia výkonu	pevná			Pre tepelné čerpadlá vzduch-voda: Menovitý prietok vzduchu, vonku	-	11650	m ³ /h
Úroveň akustického výkonu				Pre tepelné čerpadlá voda-voda alebo soľanka-voda: Menovitý prietok soľanky alebo vody, vonkajší výmenník tepla	-	---	m ³ /h
v interiéri	Lwa	---	dB				
vonku	Lwa	66	dB				
Ročná spotreba energie	Q _{HE}	14911.3	kWh				

Kontaktné údaje: WAMAK, s.r.o., Orovnica 252, 96652, Orovnica, Slovakia, info@wamak.sk

WAMAK AWK 35 EVI

ErP (EU) No 811/2013: Technické parametre vykurovacích zariadení s tepelným čerpadlom

Model	AWK 35 EVI
Tepelné čerpadlo vzduch-voda	áno
Tepelné čerpadlo soľanka-voda	nie
Tepelné čerpadlo voda-voda	nie
Nízkoteplotné tepelné čerpadlo	nie
Vybavené prídavným ohrievačom	nie
Kombinované tepelné čerpadlo s ohrievačom	nie
Teplotné použitie	stredá teplota (55°C - 47°C)
Klimatická oblasť	priemerná

Položka	Symbol	Hodnota	mj	Položka	Symbol	Hodnota	mj
Menovitý tepelný výkon pri Tdesignh	Prated	32.5	kW	Sezónna energetická účinnosť vykurovania priestoru	η_s	130.2	%
Deklarovaný výkon vykurovania pri čiastočnom zaťažení pri vnútornej teplote 20 °C a vonkajšej teplote Tj				Deklarovaný súčiniteľ výkonu alebo pomer primárnej energie pre čiastočné zaťaženie pri vnútornej teplote 20 °C a vonkajšej teplote Tj			
Tj = -7 °C	Pdh	28.4	kW	Tj = -7 °C	COPd	2.21	-
Tj = +2 °C	Pdh	32.7	kW	Tj = +2 °C	COPd	3.2	-
Tj = +7 °C	Pdh	38.0	kW	Tj = +7 °C	COPd	4.2	-
Tj = +12 °C	Pdh	44.0	kW	Tj = +12 °C	COPd	5.7	-
Tj = bivalentná teplota	Pdh	28.2	kW	Tj = bivalentná teplota	COPd	2.0	-
Tj = hraničná prevádzková teplota	Pdh	21.2	kW	Tj = hraničná prevádzková teplota	COPd	1.5	-
Bivalentná teplota	Tbiv	-7	°C	Tj = hraničná prevádzková teplota	TOL	-22	°C
Spotreba energie v iných ako aktívnych režimoch				Medzná prevádzková teplota vykurovacej vody	WTOL	65	°C
Vypnuté	Poff	0.040	kW	Prídavný ohrievač			
Režim vypnutia termostatu	Pto	0.010	kW	Menovitý tepelný výkon	Psup	13.7	kW
Pohotovostný režim	Psb	0.010	kW	Typ príkonu energie	elektrická		
Režim ohrevu kľukovej skrine	Pck	0.050	kW				
Ostatné položky							
Regulácia výkonu	pevná			Pre tepelné čerpadlá vzduch-voda: Menovitý prietok vzduchu, vonku	-	11650	m ³ /h
Úroveň akustického výkonu				Pre tepelné čerpadlá voda-voda alebo soľanka-voda: Menovitý prietok soľanky alebo vody, vonkajší výmenník tepla	-	---	m ³ /h
v interiéri	Lwa	---	dB				
vonku	Lwa	66	dB				
Ročná spotreba energie	Q _{HE}	20283.7	kWh				

Kontaktné údaje: WAMAK, s.r.o., Orovnica 252, 96652, Orovnica, Slovakia, info@wamak.sk



ENERG Y IIA
 енергия - ενεργεια IE IA



AWK 35 EVI

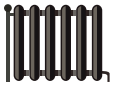

55 °C

35 °C

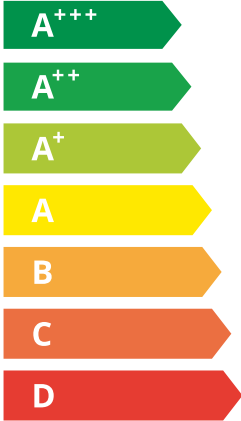

Speaker icon
--- dB

Microphone icon
66 dB

■ 35	■ 32
■ 33	■ 31
■ 32	■ 30
kW	kW

2019

811/2013

AWK 35 EVI

ErP Data

	55 °C	35 °C
Energy class	A++	A+++
η [%]	130.2	165.8
P_{rated} [kW]	33	31
Q_{HE} [kWh/y]	20284	14912
SCOP [-]	3.25	4.14
$T_{bivalent}$ [°C]	-7	-7

CONTROLLER



+ QAA55/75 class VII 3.5% ↓
 - QAA55/75 class III 1.5% ↓

Tepelný výkon - prevádzkové dáta

Version: v2024.004-AW

Stredná klim. zóna / Nízka teplota [35°C]

ZHI35K1P-TFD_R410A_1_AW

Prevádzkové podmienky		Qh	P	COP
1	A7 / W30-35	38.0	8.8	4.31
2	A2 / W35	32.3	8.8	3.67
3	A-22 / W35	19.2	8.8	2.18
A	A-7 / W34	27.0	8.6	3.14
B	A2 / W30	31.9	7.9	4.04
C	A7 / W27	37.3	7.3	5.11
D	A12 / W24	43.4	6.5	6.68
E	A-10 / W35	26.5	8.8	3.02
F	A-7 / W34	27.0	8.6	3.14

SCOP DATA EN 14825:2018	
Stredná klim. zóna / Nízka teplota [35°C]	
SCOPon	4.24
SCOPnet	4.28
SCOP	4.14
η [%]	165.76
Label	A+++
Qh [kWh]	63219.60
Pdesignh [kW]	30.6
Tbivalent [°C]	-7.00

Stredná klim. zóna / Stredná teplota [55°C]

Prevádzkové podmienky		Qh	P	COP
1	A7 / W47-55	39.2	14.2	2.77
2	A2 / W55	33.8	14.0	2.41
3	A-22 / W55	21.2	13.0	1.51
A	A-7 / W52	28.4	12.9	2.21
B	A2 / W42	32.7	10.3	3.19
C	A7 / W36	38.0	9.0	4.22
D	A12 / W30	44.0	7.7	5.73
E	A-10 / W55	28.2	13.9	2.04
F	A-7 / W55	28.8	13.9	2.07

SCOP DATA EN 14825:2018	
Stredná klim. zóna / Stredná teplota [55°C]	
SCOPon	3.31
SCOPnet	3.34
SCOP	3.25
η [%]	130.20
Label	A++
Qh [kWh]	67145.00
Pdesignh [kW]	32.5
Tbivalent [°C]	-7.00

Chladiaci výkon - prevádzkové dáta

Nízkoteplotné chladenie W 12 / 7°C

Prevádzkové podmienky		Qc	P	EER
A	A35 / W12-7	27.8	10.6	2.63
B	A30 / W12-7	28.6	9.4	3.03
C	A25 / W12-7	29.1	8.4	3.46
D	A20 / W12-7	29.5	7.5	3.93

SEER DATA EN 14825:2018 [W 12 / 7°C]	
SEERon	3.38
SEER	3.30
Qc [kWh]	16680.00
η [%]	132.11

Plošné chladenie W 23 / 18°C

Prevádzkové podmienky		Qc	P	EER
A	A35 / W23-18	37.4	10.6	3.54
B	A30 / W23-18	38.3	8.7	4.06
C	A25 / W23-18	39.0	7.6	4.63
D	A20 / W23-18	39.6	6.7	5.27

SEER DATA EN 14825:2018 [W 23 / 18°C]	
SEERon	4.52
SEER	4.39
Qc [kWh]	16680.00
η [%]	175.76

Výkonové kryvky - vykurovanie

— Qh-nom-35 - - - Qh-min-35 - - - - - Qh-max-65 — Qh-nom-45 — Qh-nom-55
— Qh-nom-65 — Pratedh-35 — Pratedh-55

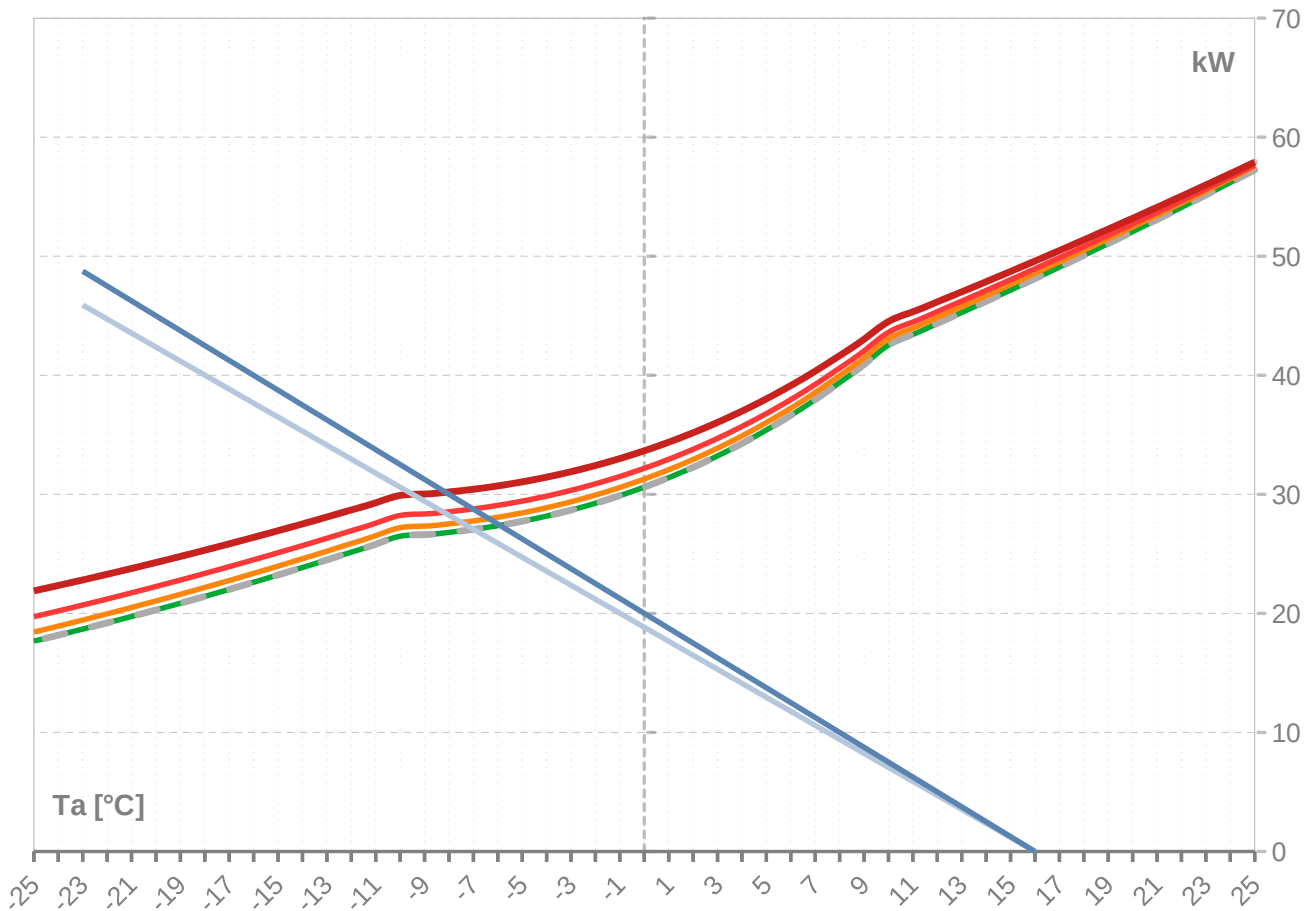

Výkonové kryvky - chladenie

— Pratedc — Qc-12/7 — Qc-23/18

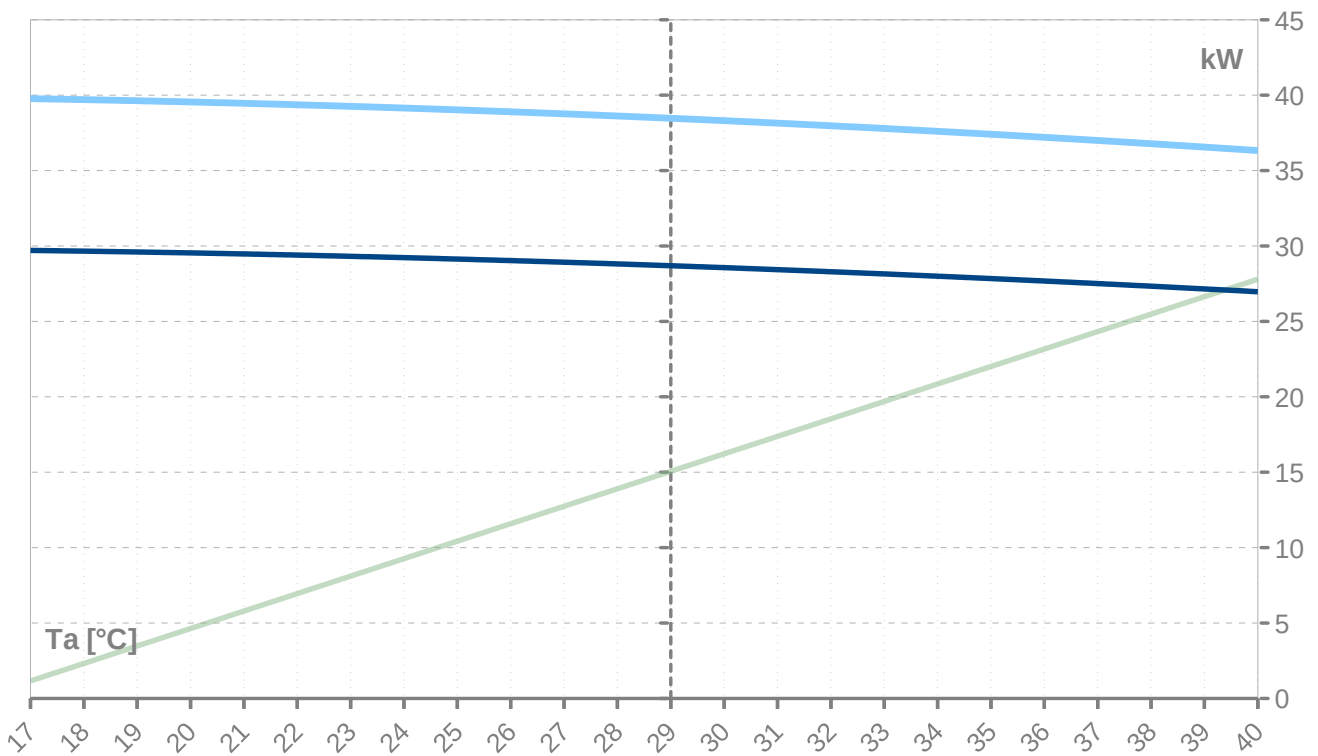

Th [°C]		35 °C								
Ta [°C]	Qh nom [kW]	Qh min [kW]	Qh max [kW]	Pin nom [kW]	Pin-min [kW]	Pin-max [kW]	COP kW / kW	I nom [A]	I min [A]	I max [A]
25	49.1	49.1		8.6	8.6		5.72	20.9	20.9	
24	49.1	49.1		8.6	8.6		5.72	20.9	20.9	
23	49.1	49.1		8.6	8.6		5.72	20.9	20.9	
22	49.1	49.1		8.6	8.6		5.72	20.9	20.9	
21	49.1	49.1		8.6	8.6		5.72	20.9	20.9	
20	49.1	49.1		8.6	8.6		5.72	20.9	20.9	
19	49.1	49.1		8.6	8.6		5.72	20.9	20.9	
18	49.1	49.1		8.6	8.6		5.72	20.9	20.9	
17	49.1	49.1		8.6	8.6		5.72	20.9	20.9	
16	48.1	48.1	48.1	8.6	8.6	8.6	5.58	20.9	20.9	20.9
15	47.2	47.2	47.2	8.6	8.6	8.6	5.45	21.0	21.0	21.0
14	46.2	46.2	46.2	8.7	8.7	8.7	5.33	21.0	21.0	21.0
13	45.3	45.3	45.3	8.7	8.7	8.7	5.20	21.0	21.0	21.0
12	44.4	44.4	44.4	8.7	8.7	8.7	5.08	21.1	21.1	21.1
11	43.4	43.4	43.4	8.7	8.7	8.7	4.97	21.1	21.1	21.1
10	42.5	42.5	42.5	8.8	8.8	8.8	4.85	21.1	21.1	21.1
9	40.9	40.9	40.9	8.8	8.8	8.8	4.66	21.2	21.2	21.2
8	39.4	39.4	39.4	8.8	8.8	8.8	4.48	21.2	21.2	21.2
7	38.0	38.0	38.0	8.8	8.8	8.8	4.31	21.2	21.2	21.2
6	36.6	36.6	36.6	8.8	8.8	8.8	4.16	21.2	21.2	21.2
5	35.4	35.4	35.4	8.8	8.8	8.8	4.02	21.2	21.2	21.2
4	34.3	34.3	34.3	8.8	8.8	8.8	3.89	21.2	21.2	21.2
3	33.2	33.2	33.2	8.8	8.8	8.8	3.77	21.2	21.2	21.2
2	32.3	32.3	32.3	8.8	8.8	8.8	3.67	21.2	21.2	21.2
1	31.4	31.4	31.4	8.8	8.8	8.8	3.57	21.2	21.2	21.2
0	30.6	30.6	30.6	8.8	8.8	8.8	3.48	21.2	21.2	21.2
-1	29.9	29.9	29.9	8.8	8.8	8.8	3.40	21.2	21.2	21.2
-2	29.2	29.2	29.2	8.8	8.8	8.8	3.33	21.2	21.2	21.2
-3	28.7	28.7	28.7	8.8	8.8	8.8	3.27	21.2	21.2	21.2
-4	28.2	28.2	28.2	8.8	8.8	8.8	3.21	21.2	21.2	21.2
-5	27.7	27.7	27.7	8.8	8.8	8.8	3.16	21.2	21.2	21.2
-6	27.4	27.4	27.4	8.8	8.8	8.8	3.12	21.2	21.2	21.2
-7	27.1	27.1	27.1	8.8	8.8	8.8	3.09	21.2	21.2	21.2
-8	26.8	26.8	26.8	8.8	8.8	8.8	3.06	21.2	21.2	21.2
-9	26.6	26.6	26.6	8.8	8.8	8.8	3.04	21.2	21.2	21.2
-10	26.5	26.5	26.5	8.8	8.8	8.8	3.02	21.2	21.2	21.2
-11	25.8	25.8	25.8	8.8	8.8	8.8	2.95	21.2	21.2	21.2
-12	25.1	25.1	25.1	8.8	8.8	8.8	2.87	21.2	21.2	21.2
-13	24.5	24.5	24.5	8.8	8.8	8.8	2.80	21.1	21.1	21.1
-14	23.9	23.9	23.9	8.8	8.8	8.8	2.73	21.1	21.1	21.1
-15	23.2	23.2	23.2	8.8	8.8	8.8	2.65	21.1	21.1	21.1
-16	22.6	22.6	22.6	8.8	8.8	8.8	2.58	21.1	21.1	21.1
-17	22.0	22.0	22.0	8.8	8.8	8.8	2.51	21.1	21.1	21.1
-18	21.4	21.4	21.4	8.8	8.8	8.8	2.44	21.1	21.1	21.1
-19	20.9	20.9	20.9	8.8	8.8	8.8	2.38	21.1	21.1	21.1
-20	20.3	20.3	20.3	8.8	8.8	8.8	2.31	21.1	21.1	21.1
-21	19.7	19.7	19.7	8.8	8.8	8.8	2.24	21.0	21.0	21.0
-22	19.2	19.2	19.2	8.8	8.8	8.8	2.18	21.0	21.0	21.0
-23	18.7	18.7	18.7	8.8	8.8	8.8	2.12	21.0	21.0	21.0
-24	18.2	18.2	18.2	8.9	8.9	8.9	2.05	21.0	21.0	21.0
-25	17.7	17.7	17.7	8.9	8.9	8.9	1.99	21.0	21.0	21.0

* pozor: pracovný rozsah nie je zohľadnený v tabuľke

ZHI35K1P-TFD_R410A_1_AW

Th [°C]		45 °C								
Ta [°C]	Qh nom [kW]	Qh min [kW]	Qh max [kW]	Pin nom [kW]	Pin-min [kW]	Pin-max [kW]	COP kW / kW	I nom [A]	I min [A]	I max [A]
25	57.6	57.6	57.6	11.0	11.0	11.0	5.22	22.8	22.8	22.8
24	56.5	56.5	56.5	11.1	11.1	11.1	5.11	22.8	22.8	22.8
23	55.5	55.5	55.5	11.1	11.1	11.1	5.01	22.8	22.8	22.8
22	54.5	54.5	54.5	11.1	11.1	11.1	4.90	22.9	22.9	22.9
21	53.5	53.5	53.5	11.1	11.1	11.1	4.80	22.9	22.9	22.9
20	52.5	52.5	52.5	11.1	11.1	11.1	4.71	22.9	22.9	22.9
19	51.5	51.5	51.5	11.2	11.2	11.2	4.61	22.9	22.9	22.9
18	50.5	50.5	50.5	11.2	11.2	11.2	4.52	22.9	22.9	22.9
17	49.5	49.5	49.5	11.2	11.2	11.2	4.43	22.9	22.9	22.9
16	48.6	48.6	48.6	11.2	11.2	11.2	4.34	22.9	22.9	22.9
15	47.6	47.6	47.6	11.2	11.2	11.2	4.26	22.9	22.9	22.9
14	46.7	46.7	46.7	11.2	11.2	11.2	4.17	22.9	22.9	22.9
13	45.8	45.8	45.8	11.2	11.2	11.2	4.09	22.9	22.9	22.9
12	44.9	44.9	44.9	11.2	11.2	11.2	4.01	22.9	22.9	22.9
11	44.0	44.0	44.0	11.2	11.2	11.2	3.93	22.9	22.9	22.9
10	43.1	43.1	43.1	11.2	11.2	11.2	3.86	22.9	22.9	22.9
9	41.5	41.5	41.5	11.2	11.2	11.2	3.72	22.9	22.9	22.9
8	40.0	40.0	40.0	11.1	11.1	11.1	3.59	22.9	22.9	22.9
7	38.6	38.6	38.6	11.1	11.1	11.1	3.47	22.8	22.8	22.8
6	37.2	37.2	37.2	11.1	11.1	11.1	3.36	22.8	22.8	22.8
5	36.0	36.0	36.0	11.1	11.1	11.1	3.26	22.8	22.8	22.8
4	34.9	34.9	34.9	11.0	11.0	11.0	3.16	22.8	22.8	22.8
3	33.9	33.9	33.9	11.0	11.0	11.0	3.07	22.7	22.7	22.7
2	32.9	32.9	32.9	11.0	11.0	11.0	2.99	22.7	22.7	22.7
1	32.1	32.1	32.1	11.0	11.0	11.0	2.92	22.7	22.7	22.7
0	31.3	31.3	31.3	11.0	11.0	11.0	2.85	22.7	22.7	22.7
-1	30.6	30.6	30.6	11.0	11.0	11.0	2.79	22.6	22.6	22.6
-2	29.9	29.9	29.9	10.9	10.9	10.9	2.74	22.6	22.6	22.6
-3	29.4	29.4	29.4	10.9	10.9	10.9	2.69	22.6	22.6	22.6
-4	28.9	28.9	28.9	10.9	10.9	10.9	2.64	22.6	22.6	22.6
-5	28.4	28.4	28.4	10.9	10.9	10.9	2.61	22.6	22.6	22.6
-6	28.1	28.1	28.1	10.9	10.9	10.9	2.57	22.6	22.6	22.6
-7	27.8	27.8	27.8	10.9	10.9	10.9	2.55	22.5	22.5	22.5
-8	27.5	27.5	27.5	10.9	10.9	10.9	2.52	22.5	22.5	22.5
-9	27.3	27.3	27.3	10.9	10.9	10.9	2.51	22.5	22.5	22.5
-10	27.2	27.2	27.2	10.9	10.9	10.9	2.50	22.5	22.5	22.5
-11	26.5	26.5	26.5	10.9	10.9	10.9	2.44	22.5	22.5	22.5
-12	25.9	25.9	25.9	10.9	10.9	10.9	2.38	22.5	22.5	22.5
-13	25.2	25.2	25.2	10.9	10.9	10.9	2.32	22.5	22.5	22.5
-14	24.6	24.6	24.6	10.9	10.9	10.9	2.26	22.4	22.4	22.4
-15	24.0	24.0	24.0	10.9	10.9	10.9	2.20	22.4	22.4	22.4
-16	23.4	23.4	23.4	10.9	10.9	10.9	2.14	22.4	22.4	22.4
-17	22.8	22.8	22.8	10.9	10.9	10.9	2.09	22.4	22.4	22.4
-18	22.2	22.2	22.2	10.9	10.9	10.9	2.03	22.3	22.3	22.3
-19	21.6	21.6	21.6	10.9	10.9	10.9	1.98	22.3	22.3	22.3
-20	21.0	21.0	21.0	10.9	10.9	10.9	1.92	22.3	22.3	22.3
-21	20.5	20.5	20.5	11.0	11.0	11.0	1.87	22.3	22.3	22.3
-22	20.0	20.0	20.0	11.0	11.0	11.0	1.82	22.3	22.3	22.3
-23	19.4	19.4	19.4	11.0	11.0	11.0	1.76	22.3	22.3	22.3
-24	18.9	18.9	18.9	11.0	11.0	11.0	1.71	22.3	22.3	22.3
-25	18.4	18.4	18.4	11.1	11.1	11.1	1.66	22.2	22.2	22.2

* pozor: pracovný rozsah nie je zohľadnený v tabuľke

Th [°C]		55 °C								
Ta [°C]	Qh nom [kW]	Qh min [kW]	Qh max [kW]	Pin nom [kW]	Pin-min [kW]	Pin-max [kW]	COP kW / kW	I nom [A]	I min [A]	I max [A]
25	57.7	57.7	57.7	14.6	14.6	14.6	3.95	26.0	26.0	26.0
24	56.7	56.7	56.7	14.6	14.6	14.6	3.88	26.0	26.0	26.0
23	55.7	55.7	55.7	14.6	14.6	14.6	3.82	26.0	26.0	26.0
22	54.7	54.7	54.7	14.6	14.6	14.6	3.75	26.0	26.0	26.0
21	53.7	53.7	53.7	14.6	14.6	14.6	3.69	26.0	26.0	26.0
20	52.7	52.7	52.7	14.6	14.6	14.6	3.62	25.9	25.9	25.9
19	51.8	51.8	51.8	14.5	14.5	14.5	3.56	25.9	25.9	25.9
18	50.8	50.8	50.8	14.5	14.5	14.5	3.50	25.9	25.9	25.9
17	49.9	49.9	49.9	14.5	14.5	14.5	3.44	25.9	25.9	25.9
16	48.9	48.9	48.9	14.5	14.5	14.5	3.38	25.9	25.9	25.9
15	48.0	48.0	48.0	14.5	14.5	14.5	3.32	25.8	25.8	25.8
14	47.1	47.1	47.1	14.4	14.4	14.4	3.26	25.8	25.8	25.8
13	46.2	46.2	46.2	14.4	14.4	14.4	3.21	25.8	25.8	25.8
12	45.3	45.3	45.3	14.4	14.4	14.4	3.15	25.8	25.8	25.8
11	44.5	44.5	44.5	14.4	14.4	14.4	3.10	25.7	25.7	25.7
10	43.6	43.6	43.6	14.3	14.3	14.3	3.04	25.7	25.7	25.7
9	42.1	42.1	42.1	14.3	14.3	14.3	2.94	25.7	25.7	25.7
8	40.6	40.6	40.6	14.2	14.2	14.2	2.85	25.6	25.6	25.6
7	39.2	39.2	39.2	14.2	14.2	14.2	2.77	25.5	25.5	25.5
6	38.0	38.0	38.0	14.1	14.1	14.1	2.69	25.5	25.5	25.5
5	36.8	36.8	36.8	14.1	14.1	14.1	2.61	25.4	25.4	25.4
4	35.7	35.7	35.7	14.1	14.1	14.1	2.54	25.4	25.4	25.4
3	34.7	34.7	34.7	14.0	14.0	14.0	2.47	25.4	25.4	25.4
2	33.8	33.8	33.8	14.0	14.0	14.0	2.41	25.3	25.3	25.3
1	32.9	32.9	32.9	14.0	14.0	14.0	2.36	25.3	25.3	25.3
0	32.2	32.2	32.2	13.9	13.9	13.9	2.31	25.2	25.2	25.2
-1	31.5	31.5	31.5	13.9	13.9	13.9	2.26	25.2	25.2	25.2
-2	30.9	30.9	30.9	13.9	13.9	13.9	2.22	25.2	25.2	25.2
-3	30.3	30.3	30.3	13.9	13.9	13.9	2.18	25.2	25.2	25.2
-4	29.8	29.8	29.8	13.9	13.9	13.9	2.15	25.1	25.1	25.1
-5	29.4	29.4	29.4	13.9	13.9	13.9	2.12	25.1	25.1	25.1
-6	29.1	29.1	29.1	13.9	13.9	13.9	2.09	25.1	25.1	25.1
-7	28.8	28.8	28.8	13.9	13.9	13.9	2.07	25.1	25.1	25.1
-8	28.5	28.5	28.5	13.9	13.9	13.9	2.06	25.1	25.1	25.1
-9	28.3	28.3	28.3	13.9	13.9	13.9	2.04	25.1	25.1	25.1
-10	28.2	28.2	28.2	13.9	13.9	13.9	2.04	25.1	25.1	25.1
-11	27.6	27.6	27.6	13.9	13.9	13.9	1.99	25.0	25.0	25.0
-12	26.9	26.9	26.9	13.9	13.9	13.9	1.94	25.0	25.0	25.0
-13	26.3	26.3	26.3	13.9	13.9	13.9	1.90	25.0	25.0	25.0
-14	25.7	25.7	25.7	13.9	13.9	13.9	1.85	25.0	25.0	25.0
-15	25.1	25.1	25.1	13.9	13.9	13.9	1.81	24.9	24.9	24.9
-16	24.5	24.5	24.5	13.9	13.9	13.9	1.76	24.9	24.9	24.9
-17	23.9	23.9	23.9	13.9	13.9	13.9	1.72	24.9	24.9	24.9
-18	23.4	23.4	23.4	13.9	13.9	13.9	1.68	24.9	24.9	24.9
-19	22.8	22.8	22.8	13.9	13.9	13.9	1.64	24.9	24.9	24.9
-20	22.3	22.3	22.3	14.0	14.0	14.0	1.59	24.8	24.8	24.8
-21	21.7	21.7	21.7	14.0	14.0	14.0	1.55	24.8	24.8	24.8
-22	21.2	21.2	21.2	14.0	14.0	14.0	1.51	24.8	24.8	24.8
-23	20.7	20.7	20.7	14.1	14.1	14.1	1.47	24.8	24.8	24.8
-24	20.2	20.2	20.2	14.1	14.1	14.1	1.43	24.8	24.8	24.8
-25	19.7	19.7	19.7	14.2	14.2	14.2	1.39	24.8	24.8	24.8

* pozor: pracovný rozsah nie je zohľadnený v tabuľke

Th [°C]		T-Max @ 65 °C								
Ta [°C]	Qh nom [kW]	Qh min [kW]	Qh max [kW]	Pin nom [kW]	Pin-min [kW]	Pin-max [kW]	COP kW / kW	I nom [A]	I min [A]	I max [A]
25	57.9	57.9	57.9	19.2	19.2	19.2	3.02	31.4	31.4	31.4
24	56.9	56.9	56.9	19.2	19.2	19.2	2.97	31.4	31.4	31.4
23	56.0	56.0	56.0	19.1	19.1	19.1	2.93	31.4	31.4	31.4
22	55.0	55.0	55.0	19.1	19.1	19.1	2.88	31.3	31.3	31.3
21	54.1	54.1	54.1	19.1	19.1	19.1	2.84	31.3	31.3	31.3
20	53.2	53.2	53.2	19.0	19.0	19.0	2.80	31.3	31.3	31.3
19	52.3	52.3	52.3	19.0	19.0	19.0	2.75	31.2	31.2	31.2
18	51.4	51.4	51.4	18.9	18.9	18.9	2.71	31.2	31.2	31.2
17	50.5	50.5	50.5	18.9	18.9	18.9	2.67	31.2	31.2	31.2
16	49.6	49.6	49.6	18.9	18.9	18.9	2.63	31.1	31.1	31.1
15	48.7	48.7	48.7	18.8	18.8	18.8	2.59	31.1	31.1	31.1
14	47.9	47.9	47.9	18.8	18.8	18.8	2.55	31.0	31.0	31.0
13	47.0	47.0	47.0	18.7	18.7	18.7	2.51	31.0	31.0	31.0
12	46.2	46.2	46.2	18.7	18.7	18.7	2.47	31.0	31.0	31.0
11	45.3	45.3	45.3	18.6	18.6	18.6	2.43	30.9	30.9	30.9
10	44.5	44.5	44.5	18.6	18.6	18.6	2.39	30.9	30.9	30.9
9	43.0	43.0	43.0	18.5	18.5	18.5	2.32	30.8	30.8	30.8
8	41.7	41.7	41.7	18.4	18.4	18.4	2.26	30.7	30.7	30.7
7	40.4	40.4	40.4	18.4	18.4	18.4	2.20	30.7	30.7	30.7
6	39.1	39.1	39.1	18.3	18.3	18.3	2.14	30.6	30.6	30.6
5	38.0	38.0	38.0	18.3	18.3	18.3	2.08	30.5	30.5	30.5
4	37.0	37.0	37.0	18.2	18.2	18.2	2.03	30.5	30.5	30.5
3	36.0	36.0	36.0	18.2	18.2	18.2	1.98	30.4	30.4	30.4
2	35.2	35.2	35.2	18.1	18.1	18.1	1.94	30.4	30.4	30.4
1	34.4	34.4	34.4	18.1	18.1	18.1	1.90	30.3	30.3	30.3
0	33.7	33.7	33.7	18.1	18.1	18.1	1.86	30.3	30.3	30.3
-1	33.0	33.0	33.0	18.1	18.1	18.1	1.83	30.3	30.3	30.3
-2	32.4	32.4	32.4	18.0	18.0	18.0	1.80	30.2	30.2	30.2
-3	31.9	31.9	31.9	18.0	18.0	18.0	1.77	30.2	30.2	30.2
-4	31.4	31.4	31.4	18.0	18.0	18.0	1.74	30.2	30.2	30.2
-5	31.0	31.0	31.0	18.0	18.0	18.0	1.72	30.2	30.2	30.2
-6	30.7	30.7	30.7	18.0	18.0	18.0	1.71	30.2	30.2	30.2
-7	30.4	30.4	30.4	18.0	18.0	18.0	1.69	30.2	30.2	30.2
-8	30.2	30.2	30.2	18.0	18.0	18.0	1.68	30.1	30.1	30.1
-9	30.0	30.0	30.0	18.0	18.0	18.0	1.67	30.1	30.1	30.1
-10	29.9	29.9	29.9	18.0	18.0	18.0	1.66	30.1	30.1	30.1
-11	29.3	29.3	29.3	18.0	18.0	18.0	1.63	30.1	30.1	30.1
-12	28.7	28.7	28.7	18.0	18.0	18.0	1.59	30.1	30.1	30.1
-13	28.1	28.1	28.1	18.0	18.0	18.0	1.56	30.1	30.1	30.1
-14	27.5	27.5	27.5	18.0	18.0	18.0	1.53	30.1	30.1	30.1
-15	26.9	26.9	26.9	18.0	18.0	18.0	1.49	30.0	30.0	30.0
-16										
-17										
-18										
-19										
-20										
-21										
-22										
-23										
-24										
-25										

* pozor: pracovný rozsah nie je zohľadnený v tabuľke

Tc [°C]		W 12 / 7 °C								
Ta [°C]	Qc nom [kW]	Qc min [kW]	Qc max [kW]	Pin [kW]	Pin min [kW]	Pin max [kW]	EER kW / kW	I nom [A]	I min [A]	I max [A]
40	27.0	27.0	27.0	11.9	11.9	11.9	2.26	23.4	23.4	23.4
39	27.2	27.2	27.2	11.6	11.6	11.6	2.34	23.2	23.2	23.2
38	27.3	27.3	27.3	11.4	11.4	11.4	2.41	23.0	23.0	23.0
37	27.5	27.5	27.5	11.1	11.1	11.1	2.48	22.8	22.8	22.8
36	27.7	27.7	27.7	10.8	10.8	10.8	2.56	22.6	22.6	22.6
35	27.8	27.8	27.8	10.6	10.6	10.6	2.63	22.5	22.5	22.5
34	28.0	28.0	28.0	10.3	10.3	10.3	2.71	22.3	22.3	22.3
33	28.1	28.1	28.1	10.1	10.1	10.1	2.79	22.1	22.1	22.1
32	28.3	28.3	28.3	9.9	9.9	9.9	2.87	22.0	22.0	22.0
31	28.4	28.4	28.4	9.7	9.7	9.7	2.95	21.8	21.8	21.8
30	28.6	28.6	28.6	9.4	9.4	9.4	3.03	21.7	21.7	21.7
29	28.7	28.7	28.7	9.2	9.2	9.2	3.11	21.5	21.5	21.5
28	28.8	28.8	28.8	9.0	9.0	9.0	3.20	21.4	21.4	21.4
27	28.9	28.9	28.9	8.8	8.8	8.8	3.28	21.2	21.2	21.2
26	29.0	29.0	29.0	8.6	8.6	8.6	3.37	21.1	21.1	21.1
25	29.1	29.1	29.1	8.4	8.4	8.4	3.46	20.9	20.9	20.9
24	29.2	29.2	29.2	8.2	8.2	8.2	3.55	20.7	20.7	20.7
23	29.3	29.3	29.3	8.0	8.0	8.0	3.64	20.6	20.6	20.6
22	29.4	29.4	29.4	7.9	7.9	7.9	3.74	20.4	20.4	20.4
21	29.5	29.5	29.5	7.7	7.7	7.7	3.83	20.2	20.2	20.2
20	29.5	29.5	29.5	7.5	7.5	7.5	3.93	20.0	20.0	20.0
19	29.6	29.6	29.6	7.3	7.3	7.3	4.04	19.8	19.8	19.8
18	29.7	29.7	29.7	7.2	7.2	7.2	4.14	19.6	19.6	19.6
17	29.7	29.7	29.7	7.0	7.0	7.0	4.25	19.4	19.4	19.4

Tc [°C]		W 23 / 18 °C								
Ta [°C]	Qc [kW]	Qh-min [kW]	Qh-max [kW]	Pin [kW]	Pin-min [kW]	Pin-max [kW]	EER kW / kW	I [A]	I-min [A]	I-max [A]
40	36.3	36.3	36.3	11.9	11.9	11.9	3.05	23.6	23.6	23.6
39	36.6	36.6	36.6	11.6	11.6	11.6	3.14	23.4	23.4	23.4
38	36.8	36.8	36.8	11.4	11.4	11.4	3.24	23.1	23.1	23.1
37	37.0	37.0	37.0	11.1	11.1	11.1	3.34	22.9	22.9	22.9
36	37.2	37.2	37.2	10.8	10.8	10.8	3.44	22.7	22.7	22.7
35	37.4	37.4	37.4	10.6	10.6	10.6	3.54	22.5	22.5	22.5
34	37.6	37.6	37.6	10.3	10.3	10.3	3.64	22.3	22.3	22.3
33	37.8	37.8	37.8	10.1	10.1	10.1	3.74	22.1	22.1	22.1
32	38.0	38.0	38.0	9.9	9.9	9.9	3.85	21.9	21.9	21.9
31	38.1	38.1	38.1	9.7	9.7	9.7	3.95	21.7	21.7	21.7
30	38.3	38.3	38.3	9.4	9.4	9.4	4.06	21.6	21.6	21.6
29	38.5	38.5	38.5	9.2	9.2	9.2	4.17	21.4	21.4	21.4
28	38.6	38.6	38.6	9.0	9.0	9.0	4.28	21.2	21.2	21.2
27	38.8	38.8	38.8	8.8	8.8	8.8	4.40	21.0	21.0	21.0
26	38.9	38.9	38.9	8.6	8.6	8.6	4.51	20.8	20.8	20.8
25	39.0	39.0	39.0	8.4	8.4	8.4	4.63	20.6	20.6	20.6
24	39.1	39.1	39.1	8.2	8.2	8.2	4.75	20.4	20.4	20.4
23	39.3	39.3	39.3	8.0	8.0	8.0	4.88	20.2	20.2	20.2
22	39.4	39.4	39.4	7.9	7.9	7.9	5.00	20.0	20.0	20.0
21	39.5	39.5	39.5	7.7	7.7	7.7	5.13	19.8	19.8	19.8
20	39.6	39.6	39.6	7.5	7.5	7.5	5.27	19.5	19.5	19.5
19	39.6	39.6	39.6	7.3	7.3	7.3	5.40	19.3	19.3	19.3
18	39.7	39.7	39.7	7.2	7.2	7.2	5.55	19.0	19.0	19.0
17	39.8	39.8	39.8	7.0	7.0	7.0	5.69	18.8	18.8	18.8

* pozor: pracovný rozsah nie je zohľadnený v tabuľke

LEGENDE:

Tz-VS: Teplota zdroja - vstup [°C]

Tv-VY: Teplota vykurovania - výstup [°C]

Tch-VY: Teplota chladenia - výstup [°C]

Qh nom: Nominálny tepelný výkon

Qh min: Minimálny tepelný výkon

Qh max: Maximálny tepelný výkon

Pin nom: Príkonnosť pri nominálnom tepelnom výkone

Pin min: Príkonnosť pri minimálnom tepelnom výkone

Pin max: Príkonnosť pri maximálnom tepelnom výkone

COP nom: Koeficient účinnosti pri nominálnom tepelnom výkone

Qc nom: Chladiaci výkon / odobrané teplo pri nominálnom tepelnom výkone

Qc min: Chladiaci výkon / odobrané teplo pri minimálnom tepelnom výkone

Qc max: Chladiaci výkon / odobrané teplo pri maximálnom tepelnom výkone

I nom: Prúd pri nominálnom tepelnom výkone

EER: Koeficient účinnosti pri nominálnom chladiacom výkone

Prevádzkové limity



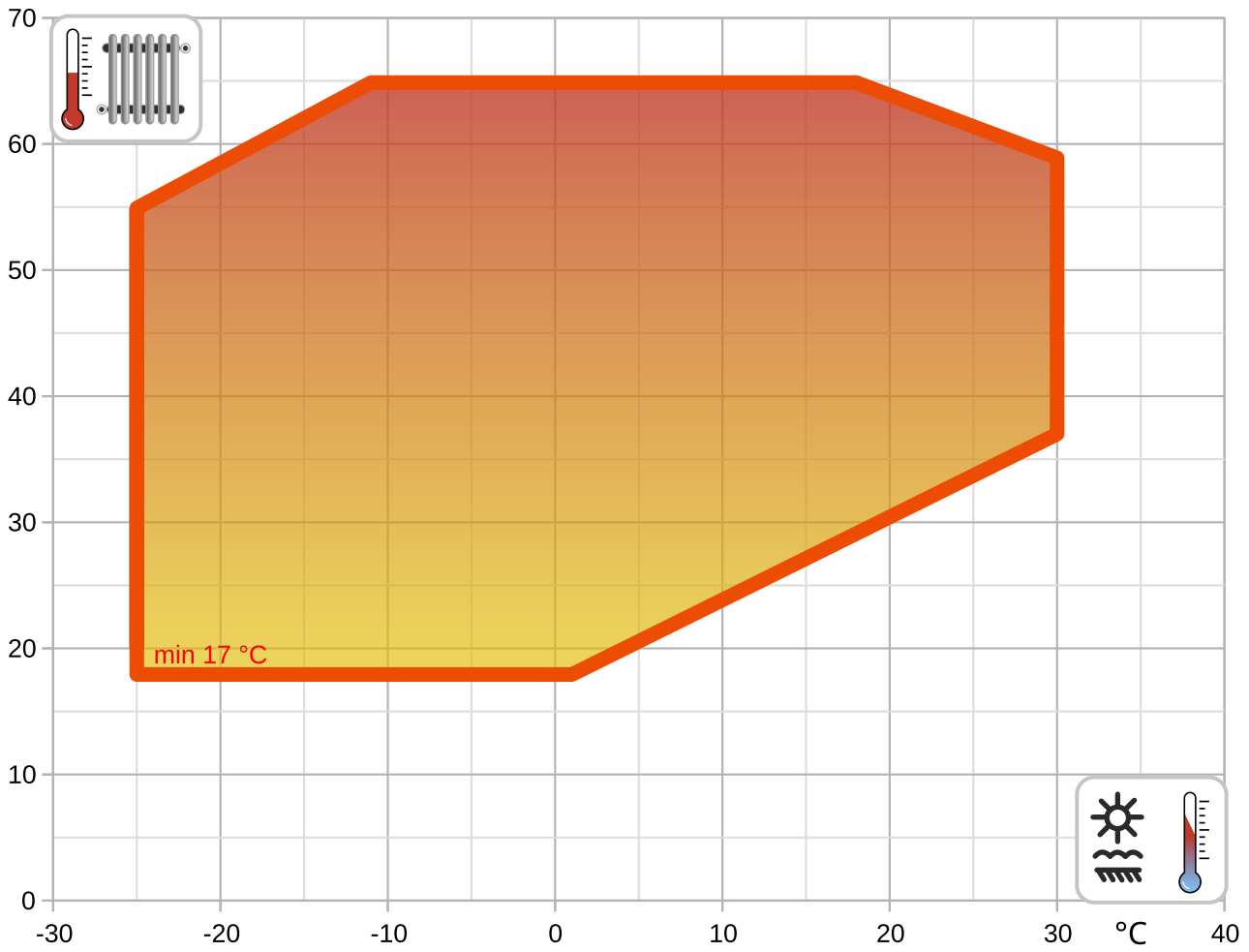

°C

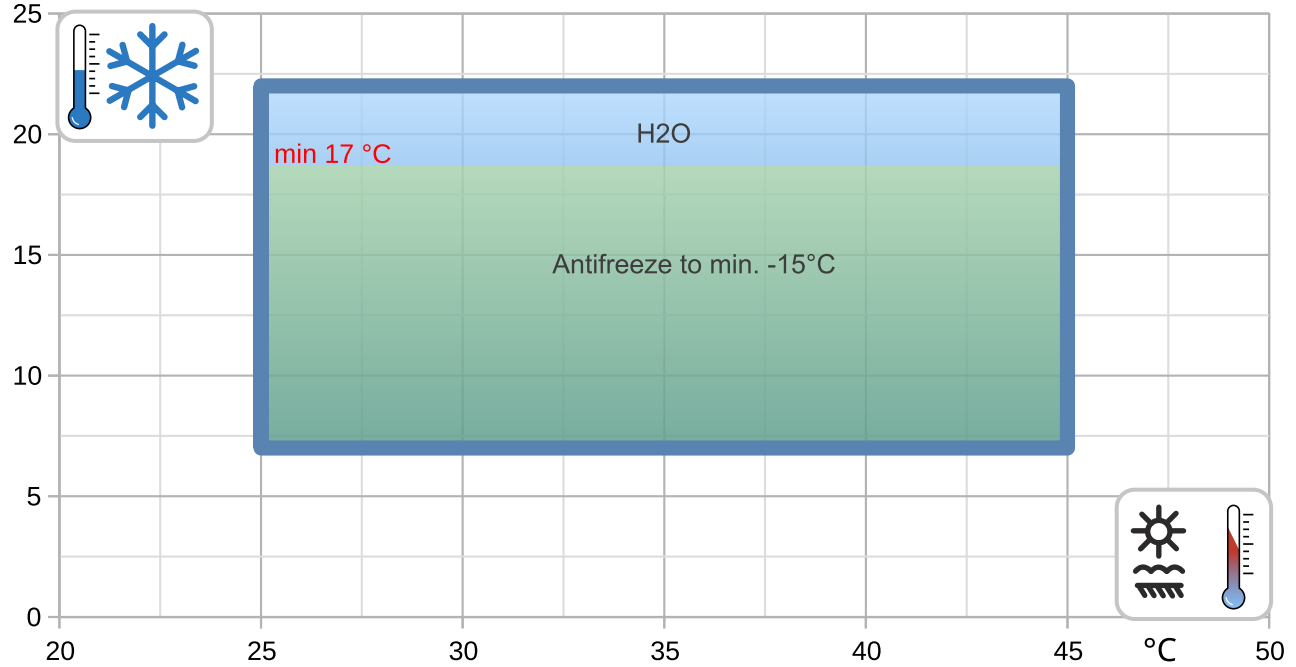

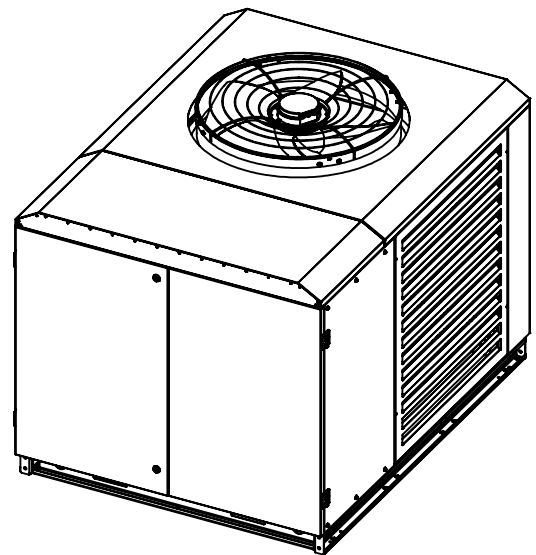
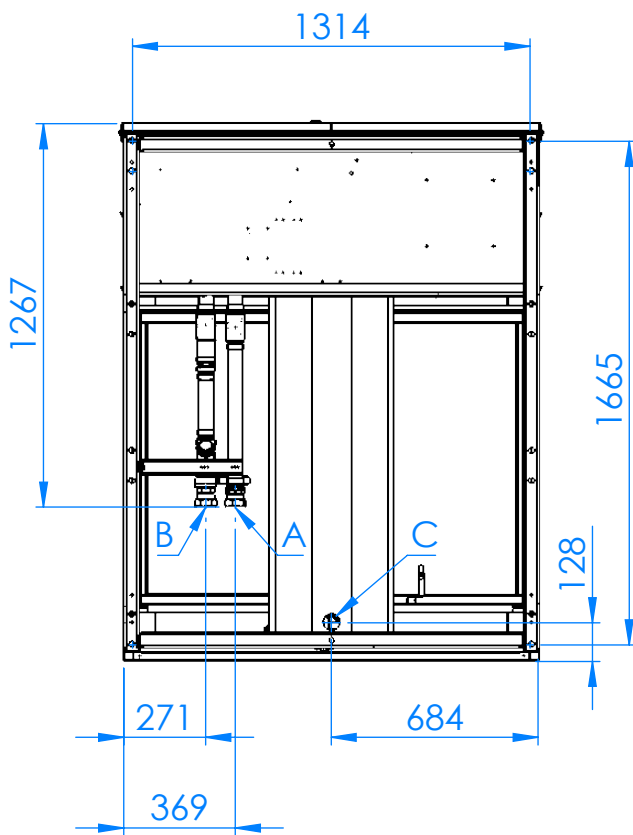
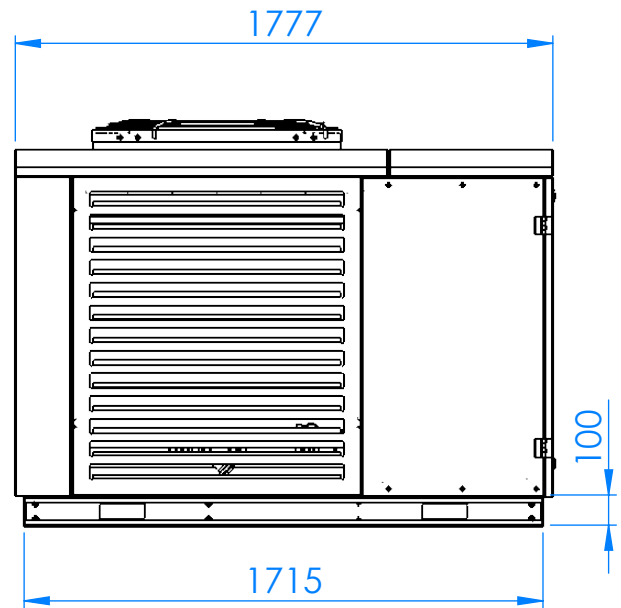
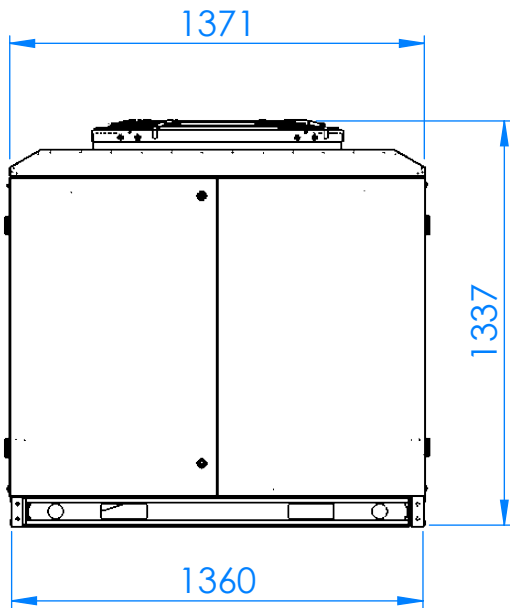
°C





- A -  → 
- B -  ← 
- C - Condens

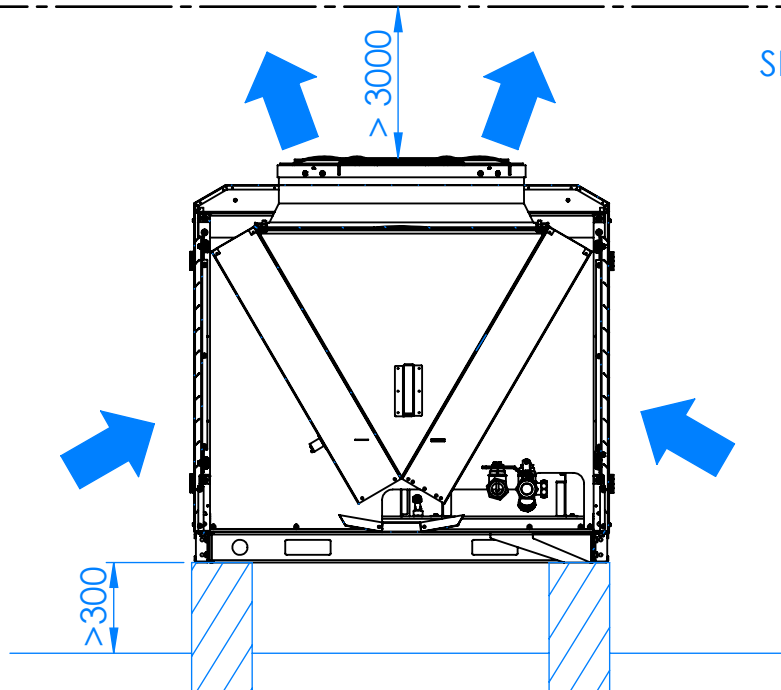
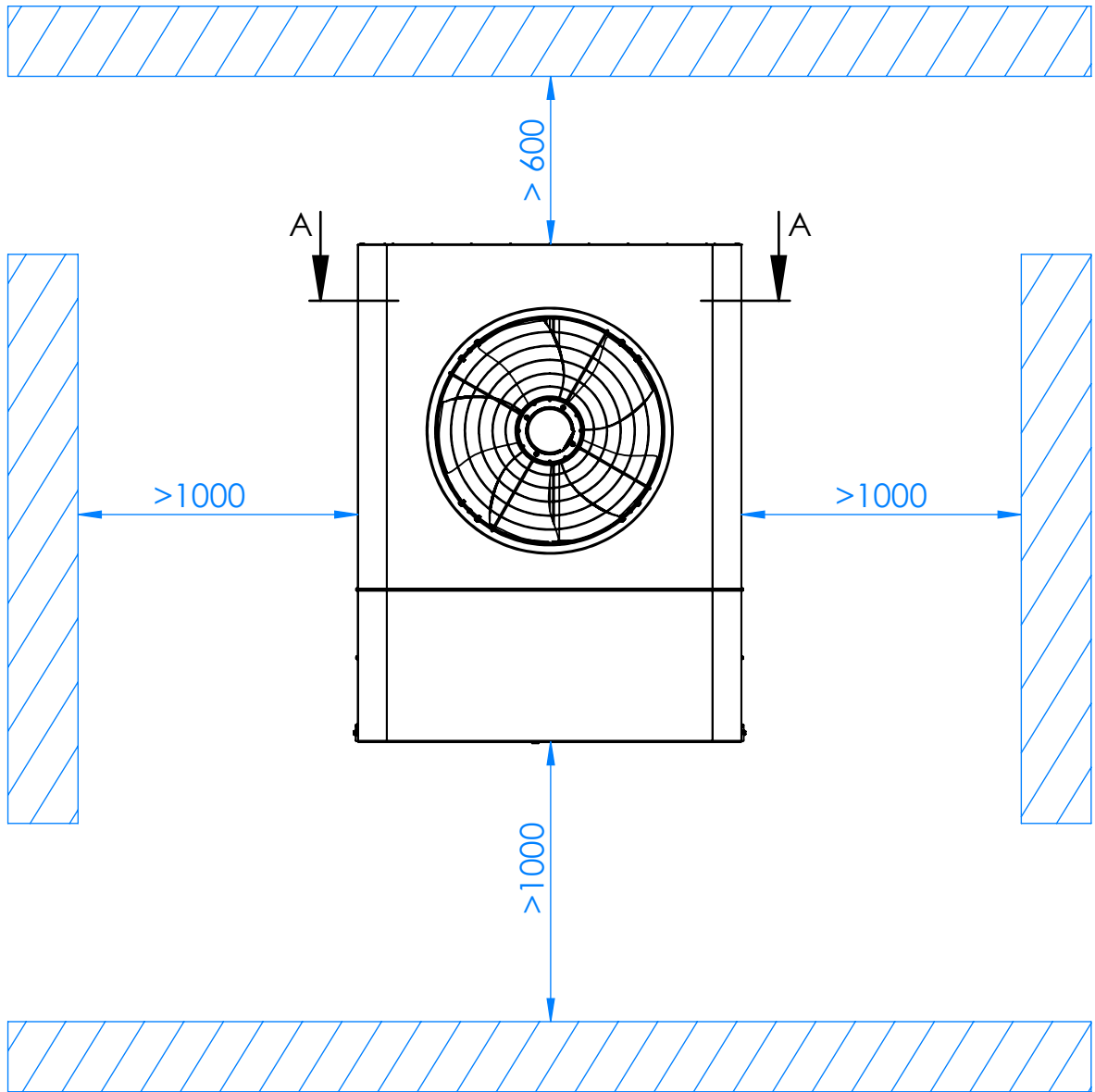

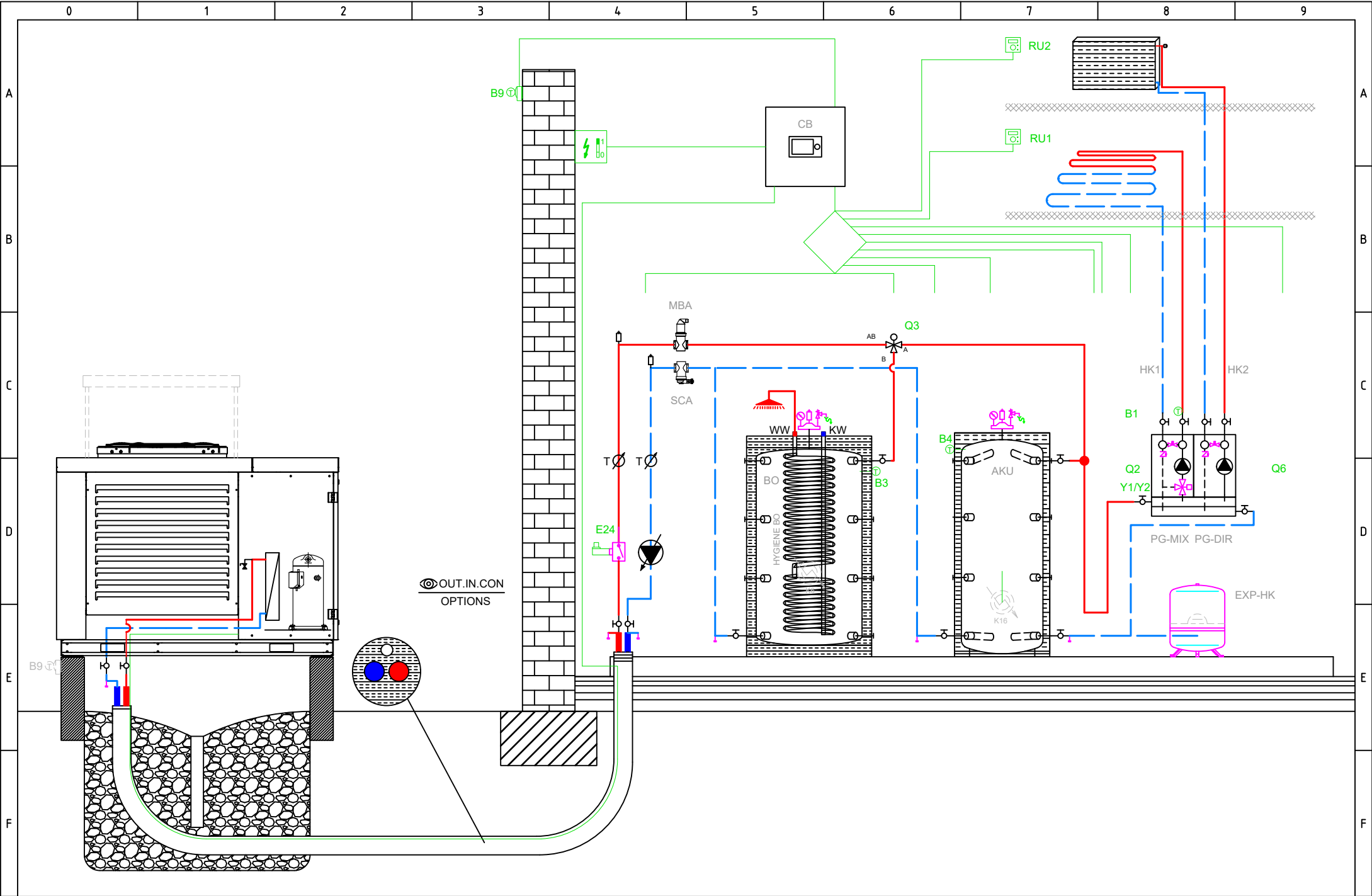

OUT.IN.CON
 OPTIONS

BASIC APPLICATION

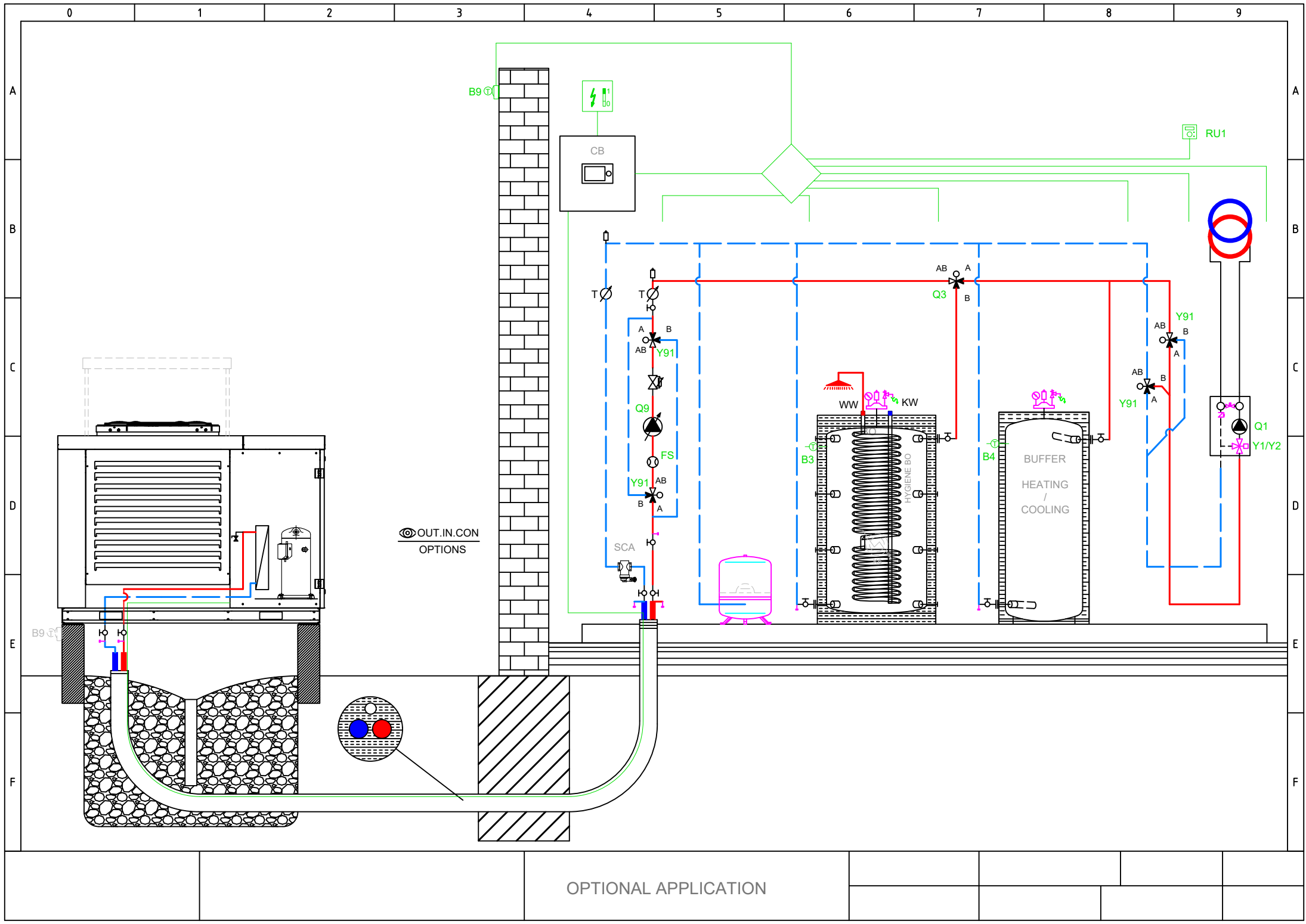



Hlavné napájanie 230V / 50 Hz
 Uzemnenie
 Nulový vodič

- E10 Spínač vysokého tlaku E10
- E11 Preťaženie kompresora E11
- E14 Preťaženie zdroja E14
- E24 Spínač prietoku spotreby E24
- K82 Ventil EVI K82

K40 Ohrev oleja K40

- L Fáza 230V
- K1 Kompresor I. stupeň K1
- Y22 Reverzný ventil Y22

Q9 Čerpadlo kondenzátora Q9

X10	1	L
X10	1	PE
X10	1	N
X11	1	EX1
X11	1	EX2
X11	1	EX3
X11	1	EX4
X12	1	QX1
X12	1	N
X12	1	QX2
X12	1	QX2i
X12	1	N
X12	1	FX3
X15	1	QX3
X15	1	QX4
X15	1	QX4i
X15	1	N
X15	1	QX5
X15	1	N
X15	1	ZX6
X15	1	N
X86	1	GX1
X86	1	H3
X86	1	M
X86	1	H1
X86	1	G+
X86	1	M
X86	1	BSB

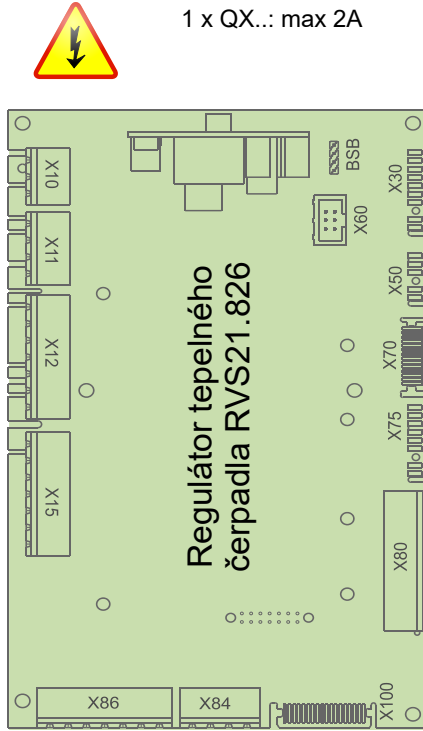

Total: max 6A
 1 x QX...: max 2A

BSB
X30
X60
X50
X70

- Pripojenie Servicetool (OCI700)
- Obslužná jednotka
- Modbus clip-in OCI351.01
- Rozširovací modul AVS75.xxx
- LPB clip-in

D1
D2
D3
UX3
M
DI6
DI7
M

- D1 Digitálny výstup 1 kúrenia
- D2 Digitálny výstup 2 chladenia
- D3 Digitálny výstup 3 TČ Zap./Vyp.
- DI6 Digitálny vstup 6 odmrazenie
- DI7 Digitálny vstup 7 Alarm

BX1
M
BX2
M
UX1
M
UX2
M

- B91 Snímač vstupu zdroja B91
- B84 Snímač výstupu zdroja B92/B84
- K19 Ventilátor K19
- 0..10V analógový signál
- Q9 Čerpadlo kondenzátora Q9
- PWM Signal

BX3
M
BX4
M

- B71 Snímač teploty spiatocky TČ B71
- B9 Snímač vonkajšej teploty B9

Hlavné napájanie 230V / 50 Hz
 Uzemnenie
 Nulový vodič

K10 Alarmový výstup K10

V81 EEV výparníka V81

X10	1	L
X10	1	PE
X10	1	N
X110	1	QX31
X110	1	QX32
X110	1	QX33
X110	1	N
X110	1	QX33
X110	1	ZX34
X110	1	N
X110	1	QX35
X110	1	QX35i
X115	1	N

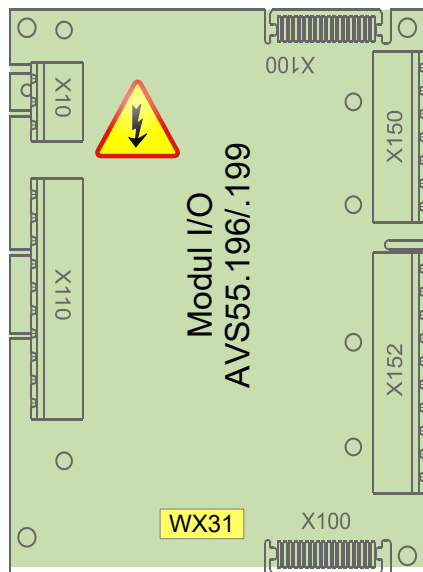

BSB
M
G+
H31
M
H32
GX1
H33
M
BX31
M
BX32
M
BX33
M
BX34
M

- 5V/12V aktívne snímače
- Meranie prietoku 10V
- Nízky tlak 0..10V
- 5V/12V aktívne snímače
- Vysoký tlak 0..10V
- B21 Snímač teploty výstupu TČ B21
- B81 Snímač horúcich plynov B81
- B85 Snímač plynov sania B85
- B83 Snímač chladiaceho média B83



- AVS75.390
- AVS75.391
- AVS75.370

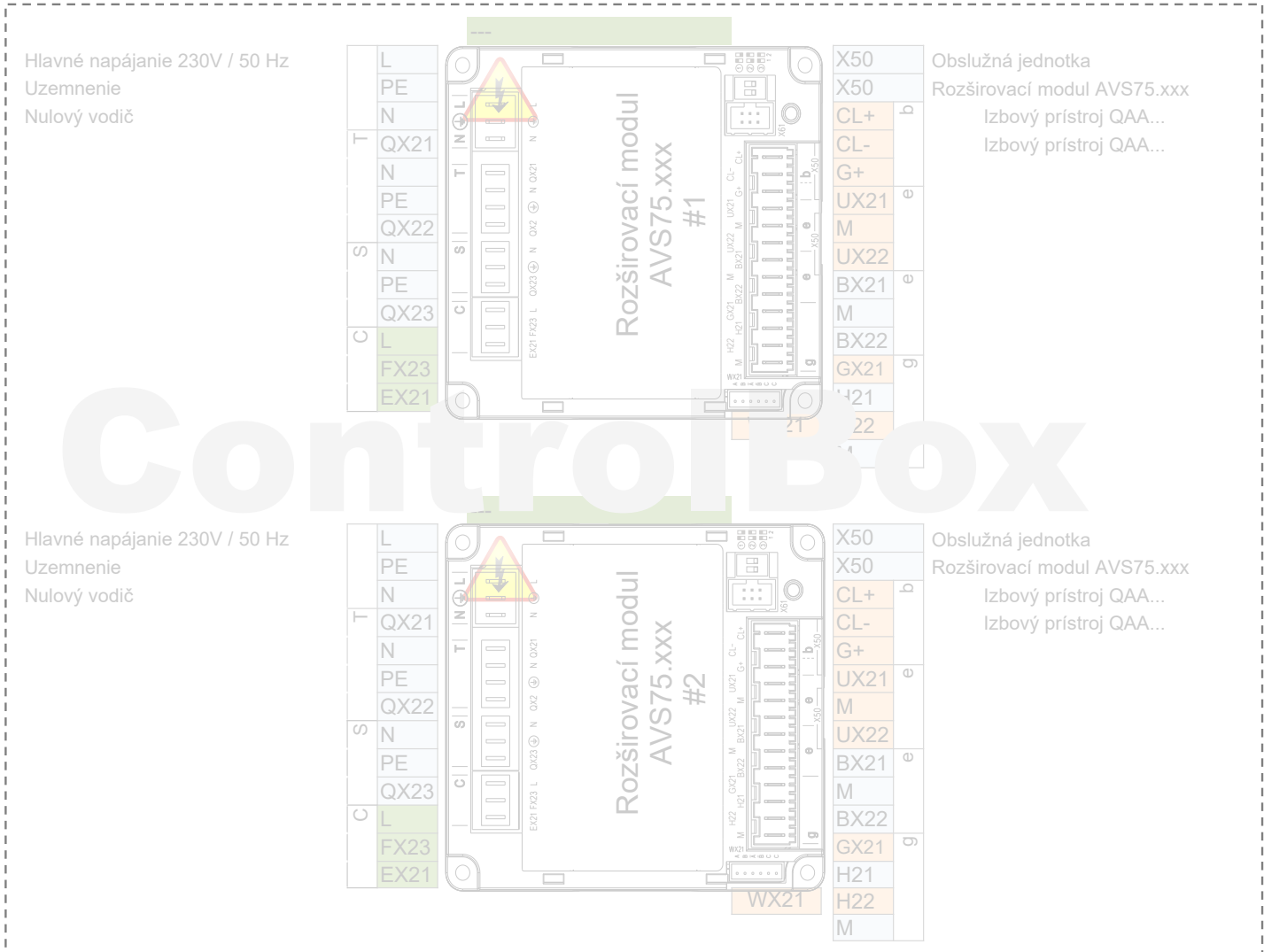

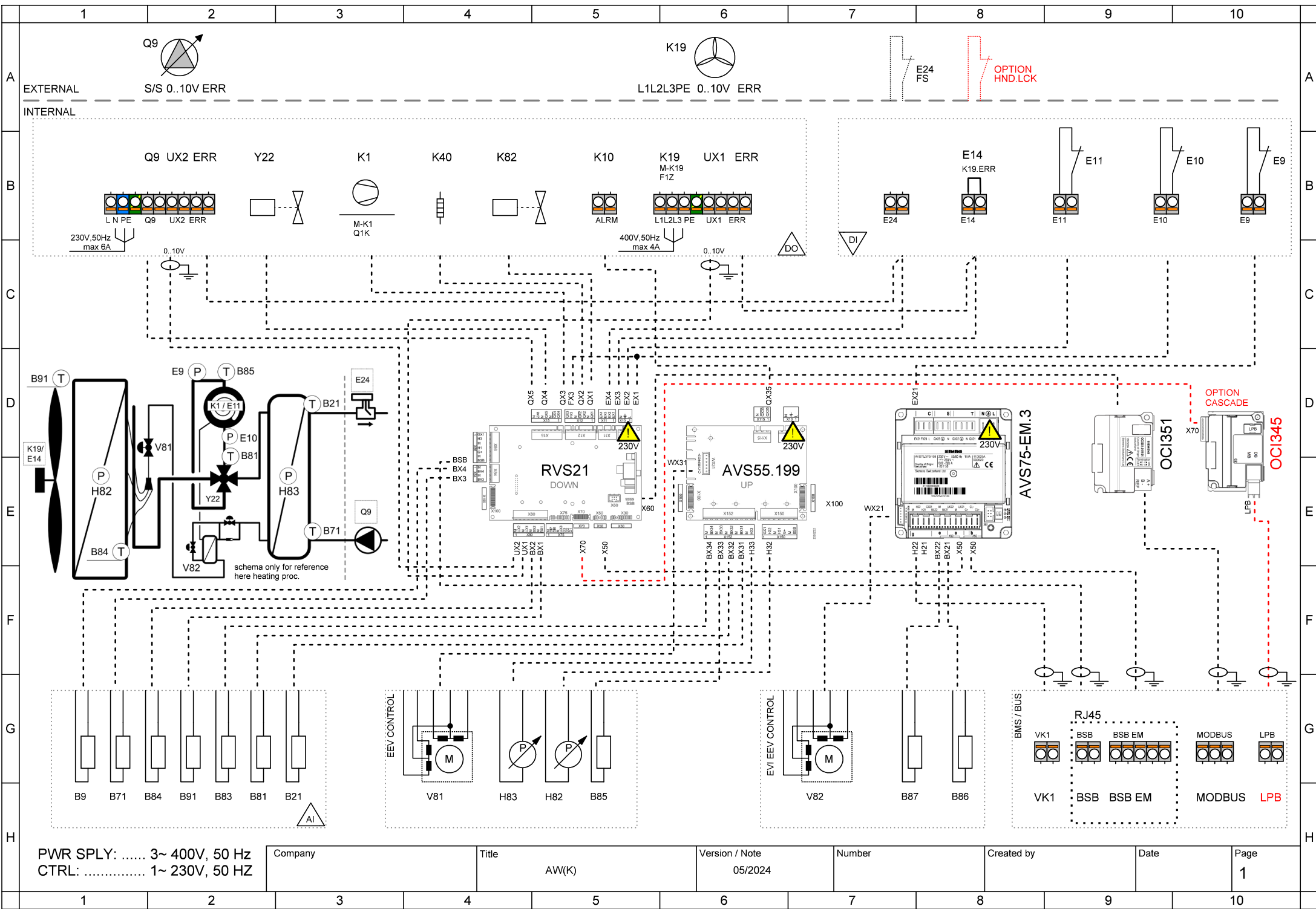

PWR SPLY: 3~ 400V, 50 Hz
 CTRL: 1~ 230V, 50 HZ

Company	Title	Version / Note	Number	Created by	Date	Page
	AW(K)	05/2024				1

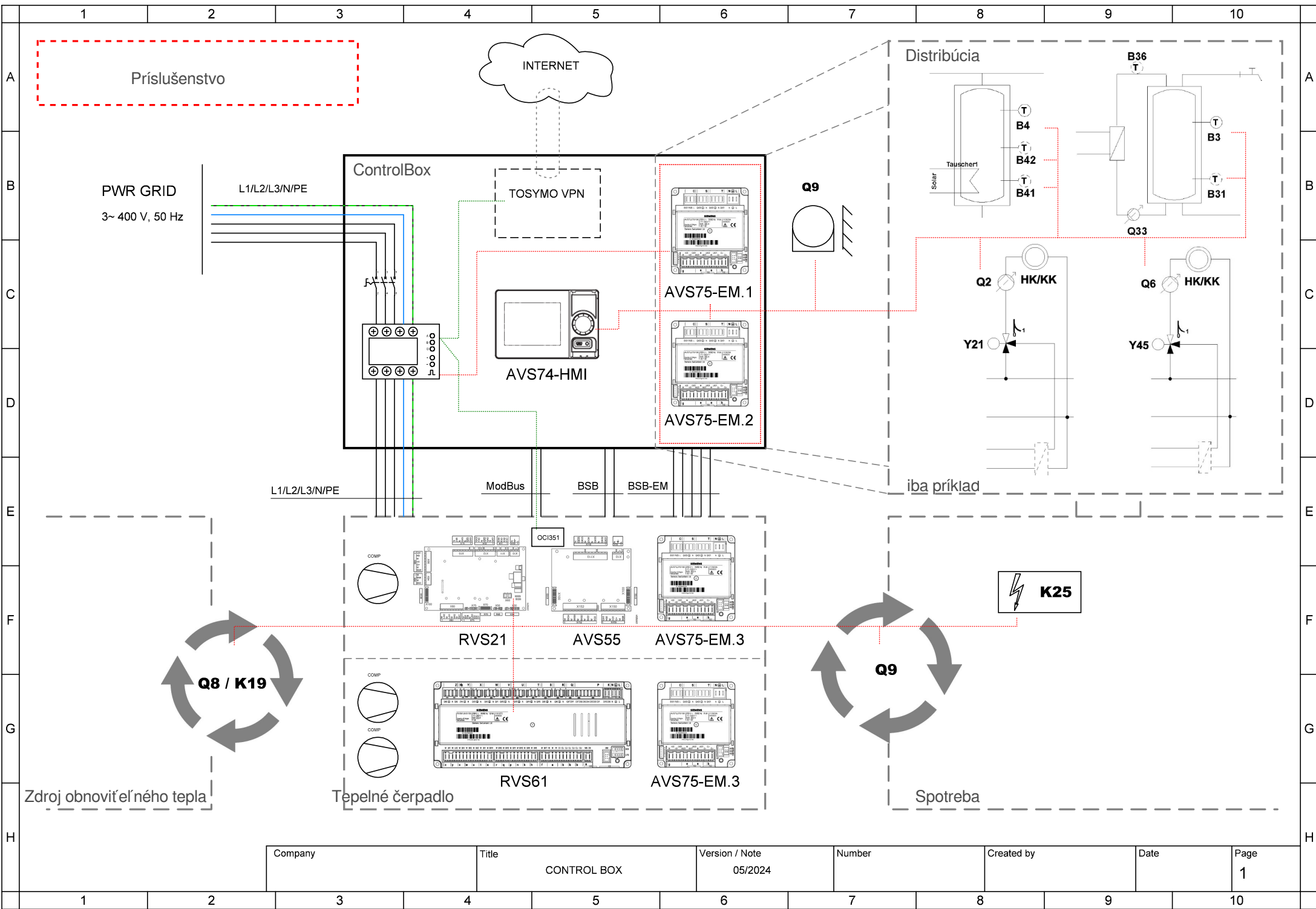

Company	Title	Version / Note	Number	Created by	Date	Page
	CONTROL BOX	05/2024				1



Company	Title	Version / Note	Number	Created by	Date	Page
	CONTROL BOX	05/2024				2



Company	Title	Version / Note	Number	Created by	Date	Page
	CONTROL BOX	05/2024				3



Company	Title	Version / Note	Number	Created by	Date	Page
	CONTROL BOX	05/2024				4

1 ControlBox

ControlBox s dvoma zabudovanými rozširujúcimi modulmi umožňuje početné možnosti ovládania aplikácie na strane spotrebiča za tepelným čerpadlom. Viac informácií nájdete v schéme ControlBoxu a v hárku s aplikačnými schémami.

2 Fixná žiadaná teplota výstupu - Zap / Vyp bezpotenciálny kontakt

2-vodičový tienený kábel 2 x 0,5 mm² - Nastavená hodnota = 45 °C (upraviteľné parametrom 1859)

Pripojovacia svorka - pozri schému zapojenia

3 Analógová regulácia žiadanej teploty výstupu 0..10V

2-vodičový tienený kábel 2 x 0,5 mm² - Nastavená hodnota: 0V = 16°C ~ 10V = 60°C (možnosť úpravy v nastavení parametrov)

Pripojovacia svorka - pozri schému zapojenia

4 ModBus RTU komunikačný príkaz

3 žilový tienený kábel min. 3 x 0,25 mm²

Pre tabuľku mapovania ModBus kontaktujte technickú podporu

5 MQTT IoT komunikačný protokol

Pre viac informácií kontaktujte technickú podporu