

Grundlegende Leistungsdaten - WAMAK TWW 48 EVI

Heizen - EN 14511		
Wärmeleistung [kW]	W10 / W35 (max)	50.5 (25.3 / 50.5)
	W10 / W35 (min)	25.3 (25.3 / 50.5)
	W10 / W34	50.6 (25.3 / 50.6)
Leistungsaufnahme [kW]	W10 / W35 (max)	8.6 (4.2 / 8.6)
	W10 / W35 (min)	4.2 (4.2 / 8.6)
	W10 / W34	8.4 (6.3 / 12.8)
Leistungszahl Heizen [COP]	W10 / W35 (max)	5.90
	W10 / W35 (min)	5.98
	W10 / W34	6.03
Jahreszeitbedingte Raumheizungs-Energieeffizienz - SCOP EN 14825		
Klimazone Durchschnitt / Niedrigtemp. [35°C]	SCOP	6.70
	η [%]	268.0
	Label	A+++
	Qhe [kWh]	15529.3
	Pdesignh [kW]	50.5
	Tbivalent [°C]	-10
Kühlung		
Kühlleistung - [kW]	A35 / W23-18	39.8
	A25 / W23-18	41.7
	A35 / W12-7	29.6
	A25 / W12-7	29.6
Jahreszeitbedingte Raumkühlungs-Energieeffizienz - SEER EN 14825		
[W 23 / 18°C]	SEER	5.29
	Qce [kWh]	4215.0
	η_c [%]	211.7
Schall EN 12102		
Schalleistungspegel - Lw	dB(A)	55.1
Schalldruckpegel - Lp	1 m dB(A)	47.1
	5 m dB(A)	33.1
	10 m dB(A)	27.1
Mechanische und Betriebs-Informationen		
Verdichterbauart (3~ 400/50)	SCROLL / 2 /	Ein/Aus
Kältemittel	R410A (GWP - 2088)	5.6 kg
Einsatzgrenze Heizungswasser - (min / max) [°C]		25 / 65
Einsatzgrenze Wärmequelle - (min / max) [°C]		-10 (7) / 30
Gewicht		275 kg

Wichtigste technische Daten - WAMAK TWW 48 EVI

Gehäuse Bezeichnung		VN1100		Daten von Wärmeabgabe	
Grundlegende Abmessungen	Hohe [mm]	1270		Einsatzgrenze Heizungswasser	MAX [°C] 65
	Breite [mm]	1100			MIN [°C] 25
	Länge [mm]	750		genauer siehe Betriebsgrenzendiagramm	
Gewicht [kg]	275		Kondensator	Anschlussdimension	2 "
Gehäuse Farbe	Grau			Bauart	BPHE
Gehäuse IP Klasse	IP20			Anzahl	1
Kältekreis				Material	AISI 316
Verdichter	Bauart	Scroll		Maximaler Überdruck - Kältemittel [bar]	45
	Leistungstufen	2		Maximaler Überdruck - Wasser [bar]	6
	Ein/Aus			Prüfdruck [bar]	70
	Leistungsfaktor Cosφ	0.64		Wärmeträger	Wasser
	Wicklungswiderstand	1.79 Ohm		Volumenstrom @ dT 5K (nom) - Wasser [m3/h]	4.37 ~ 8.74
Kältemittel		R410A		Interne Druckdifferenz - Wasser [kPa]	20
	Menge	5.6 kg		Temperaturdifferenz @ 35°C (nom)	5 K
	GWP	2088		@ 55°C	8 K
	Sicherheitsklasse	A1		@ 65°C	10 K
Kältemittelöl	POE RL32-3MAF			Daten von Erneuerbarer Energiequelle	
	Ölmenge	2 x 1.89 L		Einsatzgrenze Wärmequelle	MIN [°C] -10 (7)
Maximaler Hochdruck - Kältemittel [bar]		45			MAX [°C] 30
	PED Klasse	1		genauer siehe Betriebsgrenzendiagramm	
EVI - Dampfeinspritzung mit Economiser				Verdampfer	Anschlussdimension 2 "
Daten von Elektroanschluss					Bauart BPHE
Einspeisung [#~ V/Hz]	3~ 400/50				Anzahl 1
Strom	Nominal [A]	18.64			Material AISI 316
	Maximal [A]	32.00		Maximaler Überdruck - Kältemittel [bar]	28
	Start [A]	25.16		Wärmeträger	Wasser
Sanftanlasser	-		Maximaler Überdruck - Wasser [bar]	6	
Hauptsicherung	C32		Volumenstrom - Wasser [m3/h]	4.54 ~ 9.08	
Steuerungssystem				Interne Druckdifferenz - Wasser [kPa]	12
Hauptregler	SIEMENS	RVS 61		Temperaturdifferenz - Wasser	4 K
Erweiterungsmo dul	AVS75.3xx	AVS75.3xx	AVS75.372		
Bus Clip-In			Modbus OCI353		
Online-Verbindung		Web server OZW672	ToSyMo		
EEV Regelung		SEC61			

*** mit Zubehör

WAMAK TWW 48 EVI

ErP (EU) No 811/2013: Technische Parameter für Wärmepumpen-Raumheizgeräte

Modell	TWW 48 EVI
Luft-Wasser-Wärmepumpe	nein
Sole/Wasser-Wärmepumpe	nein
Wasser/Wasser-Wärmepumpe	ja
Niedertemperatur-Wärmepumpe	nein
Ausgestattet mit einer Zusatzheizung	nein
Wärmepumpen-Kombi-Heizgerät	nein
Temperaturanwendung	niedrig (35 °C - 30 °C)
Klimaverhältnisse	durchschnittlich

Angabe	Symbol	Wert	Ein.	Angabe	Symbol	Wert	Ein.
Nennwärmeleistung bei Tdesignh	Prated	50.5	kW	Jahreszeitbedingte Raumheizungs-Energieeffizienz	η_s	268.0	%
Ausgewiesene Heizleistung für Teillast bei einer Innentemperatur von 20 °C und einer Außentemperatur von Tj				Deklarierte Leistungszahl oder Primärenergiekennzahl für Teillast bei einer Innentemperatur von 20 °C und einer Außentemperatur von Tj			
Tj = -7 °C	Pdh	50.6	kW	Tj = -7 °C	COPd	6.03	-
Tj = +2 °C	Pdh	50.6	kW	Tj = +2 °C	COPd	6.6	-
Tj = +7 °C	Pdh	50.7	kW	Tj = +7 °C	COPd	7.1	-
Tj = +12 °C	Pdh	50.8	kW	Tj = +12 °C	COPd	7.6	-
Tj = bivalente Temperatur	Pdh	50.5	kW	Tj = bivalente Temperatur	COPd	5.9	-
Tj = Betriebsgrenztemperatur	Pdh	---	kW	Tj = Betriebsgrenztemperatur	COPd	---	-
Bivalente Temperatur	Tbiv	-10	°C	Tj = Betriebsgrenztemperatur	TOL	---	°C
Stromverbrauch in anderen Modi als dem aktiven Modus				Betriebsgrenztemperatur des Heizwassers	WTOL	65	°C
Aus-Zustand	Poff	0.010	kW	Zusatzheizung			
Thermostat-Aus-Modus	Pto	0.010	kW	Nennwärmeleistung	Psup	7.7	kW
Standby-Betrieb	Psb	0.010	kW	Art der Energiezufuhr	elektrisch		
Betriebsart Kurbelwannenheizung	Pck	0.000	kW				
Sonstige Angaben							
Leistungsregelung	mehrstufig			Für Luft/Wasser-Wärmepumpen: Nennluftvolumenstrom, Außenbereich	-	---	m ³ /h
Schalleistungspegel				Für Wasser- oder Sole/Wasser-Wärmepumpen: Nenndurchfluss der Sole oder des Wassers, Wärmetauscher im Freien	-	4.54 ~ 9.08	m ³ /h
in Innenräumen	Lwa	55	dB				
im Freien	Lwa	---	dB				
Jährlicher Energieverbrauch	Q _{HE}	15529.3	kWh				

Angaben zum Kontakt: WAMAK, s.r.o., Orovnica 252, 96652, Orovnica, Slovakia, info@wamak.sk

WAMAK TWW 48 EVI

ErP (EU) No 811/2013: Technische Parameter für Wärmepumpen-Raumheizgeräte

Modell	TWW 48 EVI
Luft-Wasser-Wärmepumpe	nein
Sole/Wasser-Wärmepumpe	nein
Wasser/Wasser-Wärmepumpe	ja
Niedertemperatur-Wärmepumpe	nein
Ausgestattet mit einer Zusatzheizung	nein
Wärmepumpen-Kombi-Heizgerät	nein
Temperaturanwendung	mittel (55 °C - 47 °C)
Klimaverhältnisse	durchschnittlich

Angabe	Symbol	Wert	Ein.	Angabe	Symbol	Wert	Ein.
Nennwärmeleistung bei Tdesignh	Prated	51.3	kW	Jahreszeitbedingte Raumheizungs-Energieeffizienz	η_s	203.9	%
Ausgewiesene Heizleistung für Teillast bei einer Innentemperatur von 20 °C und einer Außentemperatur von Tj				Deklarierte Leistungszahl oder Primärenergiekennzahl für Teillast bei einer Innentemperatur von 20 °C und einer Außentemperatur von Tj			
Tj = -7 °C	Pdh	51.5	kW	Tj = -7 °C	COPd	4.02	-
Tj = +2 °C	Pdh	51.1	kW	Tj = +2 °C	COPd	5.3	-
Tj = +7 °C	Pdh	51.1	kW	Tj = +7 °C	COPd	6.1	-
Tj = +12 °C	Pdh	51.2	kW	Tj = +12 °C	COPd	6.8	-
Tj = bivalente Temperatur	Pdh	51.3	kW	Tj = bivalente Temperatur	COPd	3.6	-
Tj = Betriebsgrenztemperatur	Pdh	---	kW	Tj = Betriebsgrenztemperatur	COPd	---	-
Bivalente Temperatur	Tbiv	-10	°C	Tj = Betriebsgrenztemperatur	TOL	---	°C
Stromverbrauch in anderen Modi als dem aktiven Modus				Betriebsgrenztemperatur des Heizwassers			
Aus-Zustand	Poff	0.010	kW	Zusatzheizung			
Thermostat-Aus-Modus	Pto	0.010	kW	Nennwärmeleistung	Psup	7.7	kW
Standby-Betrieb	Psb	0.010	kW	Art der Energiezufuhr			
Betriebsart Kurbelwannenheizung	Pck	0.000	kW	elektrisch			
Sonstige Angaben				Für Luft/Wasser-Wärmepumpen: Nennluftvolumenstrom, Außenbereich			
Leistungsregelung		mehrstufig		Für Wasser- oder Sole/Wasser-Wärmepumpen: Nenndurchfluss der Sole oder des Wassers, Wärmetauscher im Freien			
Schalleistungspegel							
in Innenräumen	Lwa	55	dB				
im Freien	Lwa	---	dB				
Jährlicher Energieverbrauch	Q _{HE}	20754.1	kWh				

Angaben zum Kontakt: WAMAK, s.r.o., Orovnic 252, 96652, Orovnic, Slovakia, info@wamak.sk



ENERG Y IIA
 енергия - ενεργεια IE IA

WAMAK

TWW 48 EVI

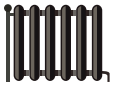

55 °C

35 °C



A+++

A+++



55 dB



--- dB

■ 54
 ■ 52
 ■ 51
 kW

■ 52
 ■ 51
 ■ 48
 kW



2019

811/2013

TWW 48 EVI

ErP Data

	55 °C	35 °C
Energy class	A+++	A+++
η [%]	203.9	268.0
P_{rated} [kW]	52	51
Q_{HE} [kWh/y]	20755	15530
SCOP [-]	5.10	6.70
$T_{bivalent}$ [°C]	-10	-10

CONTROLLER



+ QAA55/75
 - QAA55/75

class VII
 class III

3.5% ↓
 1.5% ↓

Heizleistung Daten

Version: v2024.010-BW-WW

Quelle - Sole [0°C] / Niedrigtemp. [35°C]

ZHI18K1P-TFM_R410A_2_BWW

Betriebsbedingungen	Qh	P	COP
1 B0 / W30-35	39.9	8.7	4.61
2 B0 / W30-35 (MIN)	20.0	4.3	4.68
A B0 / Wxx-34	39.9	8.5	4.72
B B0 / Wxx-30	39.7	7.7	5.15
C B0 / Wxx-27	19.8	3.6	5.57
D B0 / Wxx-24	19.8	3.3	5.93
E B0 / Wxx-35	39.9	8.7	4.61
F B0 / Wxx-35	39.9	8.7	4.61

SCOP DATA EN 14825:2018	
Quelle - Sole [0°C] / Niedrigtemp. [35°C]	
SCOPon	5.25
SCOPnet	5.25
SCOP	5.23
η [%]	209.37
Label	A+++
Qh [kWh]	15707
Pdesignh [kW]	39.9
Tbivalent [°C]	-10

Quelle - Sole [0°C] / Mitteltemp.. [55°C]

Betriebsbedingungen	Qh	P	COP
1 B0 / W47-55	41.5	14.2	2.92
2 B0 / W47-55 (MIN)	20.7	6.9	2.96
A B0 / Wxx-52	41.5	12.8	3.34
B B0 / Wxx-42	41.1	9.7	4.27
C B0 / Wxx-36	20.2	4.2	4.79
D B0 / Wxx-30	20.1	3.8	5.29
E B0 / Wxx-55	41.5	14.2	2.92
F B0 / Wxx-54	41.6	13.2	3.16

SCOP DATA EN 14825:2018	
Quelle - Sole [0°C] / Mitteltemp.. [55°C]	
SCOPon	4.14
SCOPnet	4.14
SCOP	4.13
η [%]	165.16
Label	A+++
Qh [kWh]	20723
Pdesignh [kW]	41.5
Tbivalent [°C]	-10

Quelle - Wasser [10°C] / Niedrigtemp. [35°C]

Betriebsbedingungen	Qh	P	COP
1 W10 / W30-35	50.5	8.6	5.90
2 W10 / W30-35 (MIN)	25.3	4.2	5.98
A W10 / Wxx-34	50.6	8.4	6.03
B W10 / Wxx-30	50.6	7.7	6.60
C W10 / Wxx-27	50.7	7.2	7.13
D W10 / Wxx-24	50.8	6.8	7.57
E W10 / Wxx-35	50.5	8.6	5.90
F W10 / Wxx-35	50.5	8.6	5.90

SCOP DATA EN 14825:2018	
Quelle - Wasser [10°C] / Niedrigtemp. [35°C]	
SCOPon	6.72
SCOPnet	6.72
SCOP	6.70
η [%]	268.02
Label	A+++
Qh [kWh]	15529
Pdesignh [kW]	50.5
Tbivalent [°C]	-10.00

Quelle - Wasser [10°C] / Mitteltemp. [55°C]

Betriebsbedingungen		Qh	P	COP
1	W10 / W47-55	51.3	14.2	3.60
2	W10 / W47-55 (MIN)	25.6	7.0	3.65
A	W10 / Wxx-52	51.5	12.8	4.02
B	W10 / Wxx-42	51.1	9.7	5.29
C	W10 / Wxx-36	51.1	8.5	6.12
D	W10 / Wxx-30	51.2	7.7	6.77
E	W10 / Wxx-55	51.3	14.2	3.60
F	W10 / Wxx-55	51.3	14.2	3.60

SCOP DATA EN 14825:2018	
Quelle - Wasser [10°C] / Mitteltemp. [55°C]	
SCOPon	5.11
SCOPnet	5.11
SCOP	5.10
η [%]	203.85
Label	A+++
Qh [kWh]	20754
Pdesignh [kW]	51.3
Tbivalent [°C]	-10.00

Niedrigtemperatur Kühlung W 12 / 7°C

Betriebsbedingungen		Qc	P	EER
A	W30-35 / W12-7	30.4	9.3	3.27
B	W26-xx / W12-7	31.0	8.5	3.67
C	W22-xx / W12-7	31.6	7.7	4.09
D	W18-xx / W12-7	31.8	7.4	4.31

SEER DATA EN 14825:2018 [W 12 / 7°C]	
SEERon	3.96
SEER	3.95
Qc [kWh]	17760
η [%]	158.09

Flächenkühlung W 23 / 18°C

Betriebsbedingungen		Qc	P	EER
A	W50-xx / W23-18	36.2	15.3	2.37
B	W40-xx / W23-18	38.6	11.9	3.25
C	W30-35 / W23-18	40.8	9.3	4.39
D	W26-xx / W23-18	41.6	8.5	4.91

SEER DATA EN 14825:2018 [W 23 / 18°C]	
SEERon	5.30
SEER	5.29
Qc [kWh]	17760
η [%]	211.71

Leistungslinien - Heizen

- Qh-nom-35 - - - Qh-min-35 - - - - Qh-max-65 — Qh-nom-45 — Qh-nom-55
- Qh-nom-65

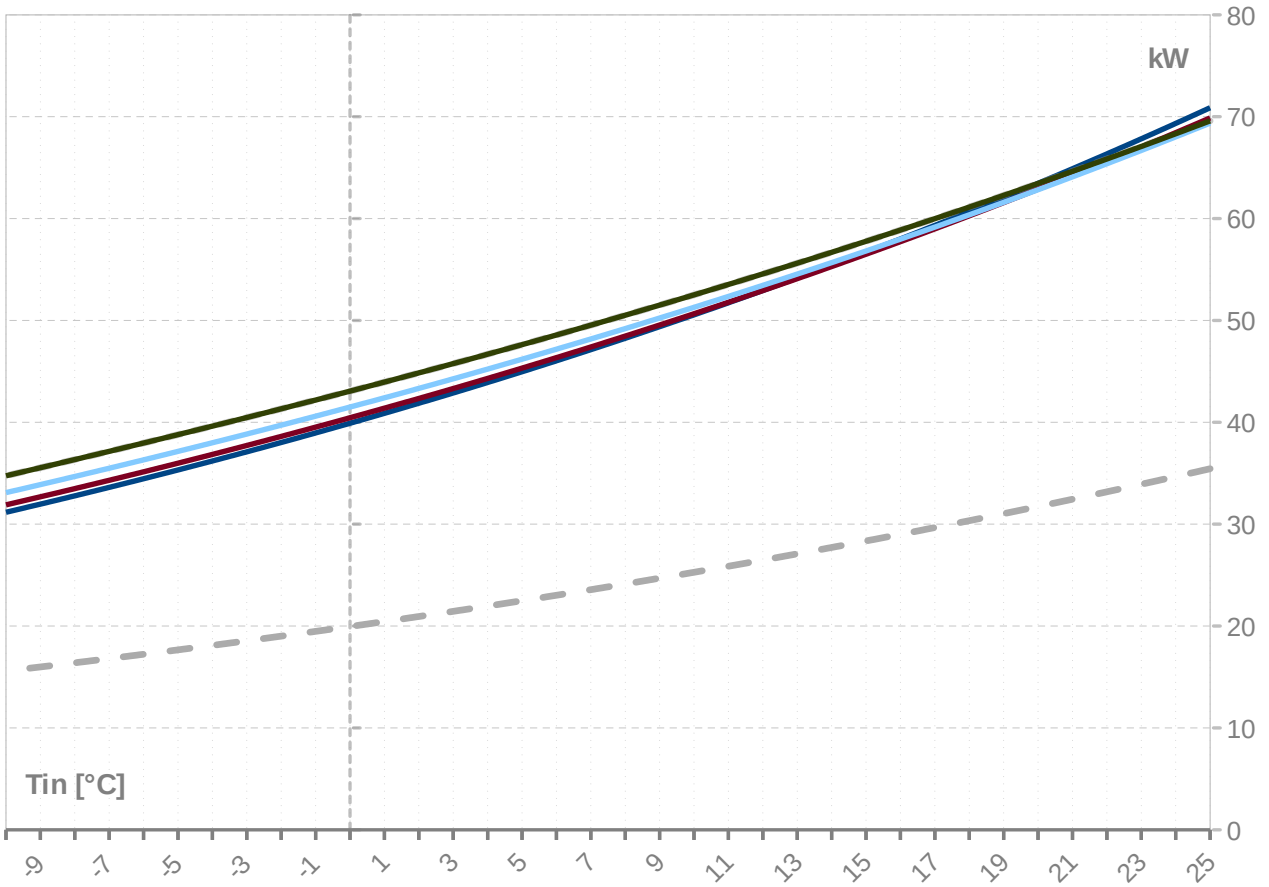

Leistungslinien - Kühlen

- Qc-nom-12-7 — Qc-nom-23-18

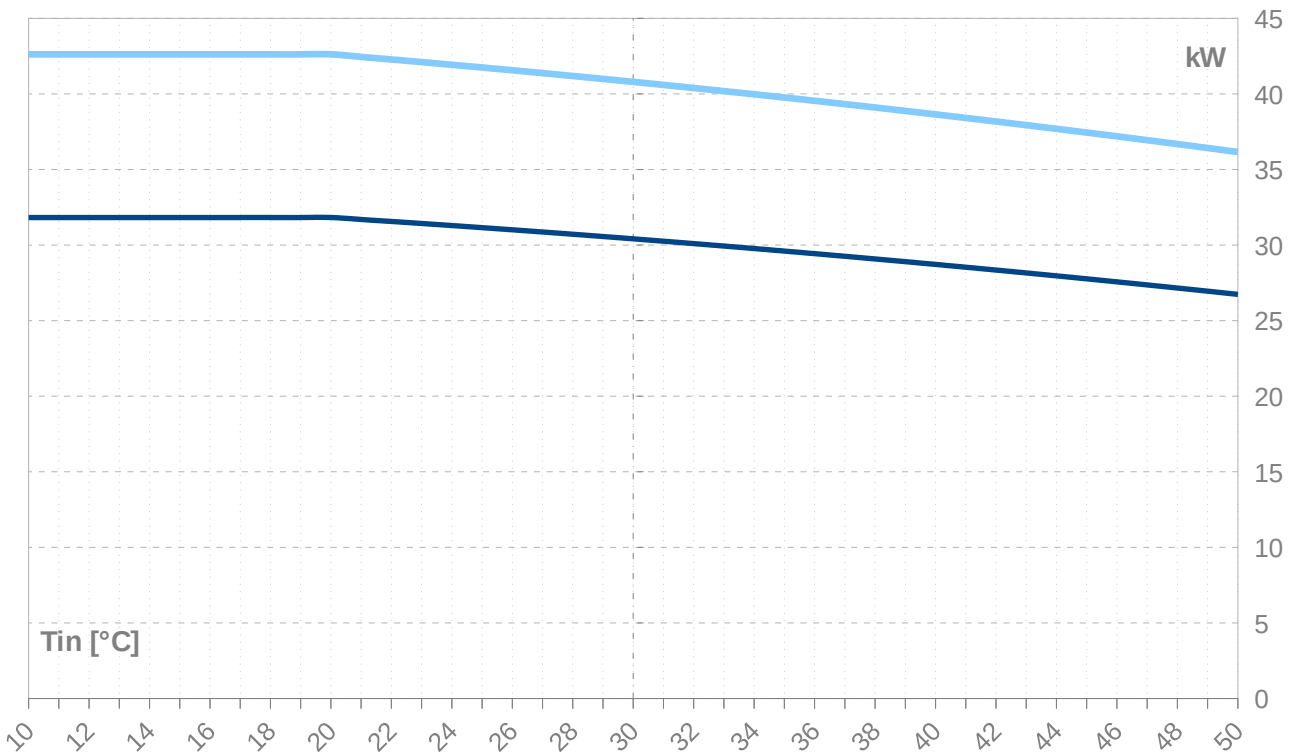

Tws -VL		35										
Twq -RL	Qh nom	Qh min	Qh max	Pin nom	Pin min	Pin max	COP nom	Qc nom	Qc min	Qc max	I nom	
[°C]	[kW]	[kW]	[kW]	[kW]	[kW]	[kW]	kW / kW	[kW]	[kW]	[kW]	[A]	
25	70.9	35.4	70.9	8.6	4.2	8.6	8.27	62.9	31.4	62.9	18.7	
24	69.3	34.7	69.3	8.6	4.2	8.6	8.10	61.3	30.7	61.3	18.7	
23	67.8	33.9	67.8	8.6	4.2	8.6	7.93	59.8	29.9	59.8	18.7	
22	66.3	33.2	66.3	8.5	4.2	8.5	7.76	58.4	29.2	58.4	18.7	
21	64.9	32.4	64.9	8.5	4.2	8.5	7.60	56.9	28.5	56.9	18.7	
20	63.5	31.7	63.5	8.5	4.2	8.5	7.43	55.5	27.7	55.5	18.7	
19	62.1	31.0	62.1	8.5	4.2	8.5	7.27	54.1	27.0	54.1	18.7	
18	60.7	30.3	60.7	8.5	4.2	8.5	7.11	52.7	26.4	52.7	18.7	
17	59.3	29.7	59.3	8.5	4.2	8.5	6.95	51.4	25.7	51.4	18.7	
16	58.0	29.0	58.0	8.5	4.2	8.5	6.79	50.0	25.0	50.0	18.7	
15	56.7	28.3	56.7	8.5	4.2	8.5	6.64	48.7	24.4	48.7	18.7	
14	55.4	27.7	55.4	8.5	4.2	8.5	6.48	47.4	23.7	47.4	18.7	
13	54.2	27.1	54.2	8.6	4.2	8.6	6.33	46.2	23.1	46.2	18.7	
12	52.9	26.5	52.9	8.6	4.2	8.6	6.18	44.9	22.5	44.9	18.7	
11	51.7	25.9	51.7	8.6	4.2	8.6	6.04	43.7	21.9	43.7	18.7	
10	50.5	25.3	50.5	8.6	4.2	8.6	5.90	42.5	21.3	42.5	18.7	
9	49.4	24.7	49.4	8.6	4.2	8.6	5.76	41.4	20.7	41.4	18.7	
8	48.3	24.1	48.3	8.6	4.2	8.6	5.62	40.2	20.1	40.2	18.7	
7	47.1	23.6	47.1	8.6	4.2	8.6	5.48	39.1	19.6	39.1	18.7	
6	46.0	23.0	46.0	8.6	4.2	8.6	5.35	38.0	19.0	38.0	18.7	
5	45.0	22.5	45.0	8.6	4.2	8.6	5.22	36.9	18.5	36.9	18.7	
4	43.9	22.0	43.9	8.6	4.3	8.6	5.09	35.9	17.9	35.9	18.7	
3	42.9	21.4	42.9	8.6	4.3	8.6	4.97	34.8	17.4	34.8	18.8	
2	41.9	20.9	41.9	8.6	4.3	8.6	4.85	33.8	16.9	33.8	18.8	
1	40.9	20.4	40.9	8.6	4.3	8.6	4.73	32.8	16.4	32.8	18.8	
0	39.9	20.0	39.9	8.7	4.3	8.7	4.61	31.8	15.9	31.8	18.8	
-1	38.9	19.5	38.9	8.7	4.3	8.7	4.50	30.9	15.4	30.9	18.8	
-2	38.0	19.0	38.0	8.7	4.3	8.7	4.39	29.9	15.0	29.9	18.8	
-3	37.1	18.5	37.1	8.7	4.3	8.7	4.28	29.0	14.5	29.0	18.8	
-4	36.2	18.1	36.2	8.7	4.3	8.7	4.17	28.1	14.0	28.1	18.8	
-5	35.3	17.7	35.3	8.7	4.3	8.7	4.07	27.2	13.6	27.2	18.8	
-6	34.5	17.2	34.5	8.7	4.3	8.7	3.97	26.3	13.2	26.3	18.8	
-7	33.6	16.8	33.6	8.7	4.3	8.7	3.87	25.5	12.7	25.5	18.8	
-8	32.8	16.4	32.8	8.7	4.3	8.7	3.77	24.7	12.3	24.7	18.8	
-9	32.0	16.0	32.0	8.7	4.3	8.7	3.68	23.9	11.9	23.9	18.8	
-10	31.2	15.6	31.2	8.7	4.3	8.7	3.59	23.1	11.5	23.1	18.8	
-11	30.4	15.2	30.4	8.7	4.3	8.7	3.50	22.3	11.1	22.3	18.8	
-12	29.6	14.8	29.6	8.7	4.3	8.7	3.41	21.5	10.8	21.5	18.8	
-13	28.9	14.4	28.9	8.7	4.3	8.7	3.33	20.8	10.4	20.8	18.8	
-14	28.1	14.1	28.1	8.7	4.3	8.7	3.25	20.0	10.0	20.0	18.8	
-15	27.4	13.7	27.4	8.6	4.3	8.6	3.17	19.3	9.7	19.3	18.8	

-- Achtung: Betriebsgrenzen beachten - nicht in Tabelle festgehalten

ZHI18K1P-TFM_R410A_2_BWW

Tws -VL	45										
[°C]	Qh nom	Qh min	Qh max	Pin nom	Pin min	Pin max	COP nom	Qc nom	Qc min	Qc max	I nom
[°C]	[kW]	[kW]	[kW]	[kW]	[kW]	[kW]	kW / kW	[kW]	[kW]	[kW]	[A]
25	69.9	34.9	69.9	10.6	5.2	10.6	6.57	60.0	30.0	60.0	20.7
24	68.4	34.2	68.4	10.6	5.2	10.6	6.43	58.5	29.2	58.5	20.7
23	67.0	33.5	67.0	10.7	5.3	10.7	6.29	57.1	28.5	57.1	20.8
22	65.6	32.8	65.6	10.7	5.3	10.7	6.15	55.7	27.8	55.7	20.8
21	64.2	32.1	64.2	10.7	5.3	10.7	6.02	54.3	27.1	54.3	20.8
20	62.9	31.4	62.9	10.7	5.3	10.7	5.88	52.9	26.5	52.9	20.8
19	61.6	30.8	61.6	10.7	5.3	10.7	5.75	51.6	25.8	51.6	20.8
18	60.3	30.1	60.3	10.7	5.3	10.7	5.62	50.3	25.1	50.3	20.8
17	59.0	29.5	59.0	10.7	5.3	10.7	5.50	49.0	24.5	49.0	20.9
16	57.7	28.9	57.7	10.7	5.3	10.7	5.37	47.7	23.8	47.7	20.9
15	56.5	28.2	56.5	10.8	5.3	10.8	5.25	46.5	23.2	46.5	20.9
14	55.3	27.6	55.3	10.8	5.3	10.8	5.13	45.2	22.6	45.2	20.9
13	54.1	27.0	54.1	10.8	5.3	10.8	5.02	44.0	22.0	44.0	20.9
12	52.9	26.5	52.9	10.8	5.3	10.8	4.90	42.8	21.4	42.8	20.9
11	51.8	25.9	51.8	10.8	5.3	10.8	4.79	41.7	20.8	41.7	21.0
10	50.7	25.3	50.7	10.8	5.3	10.8	4.68	40.6	20.3	40.6	21.0
9	49.6	24.8	49.6	10.8	5.3	10.8	4.57	39.4	19.7	39.4	21.0
8	48.5	24.2	48.5	10.8	5.3	10.8	4.47	38.3	19.2	38.3	21.0
7	47.4	23.7	47.4	10.9	5.4	10.9	4.37	37.3	18.6	37.3	21.0
6	46.3	23.2	46.3	10.9	5.4	10.9	4.27	36.2	18.1	36.2	21.0
5	45.3	22.7	45.3	10.9	5.4	10.9	4.17	35.2	17.6	35.2	21.0
4	44.3	22.2	44.3	10.9	5.4	10.9	4.07	34.1	17.1	34.1	21.0
3	43.3	21.7	43.3	10.9	5.4	10.9	3.98	33.2	16.6	33.2	21.0
2	42.3	21.2	42.3	10.9	5.4	10.9	3.89	32.2	16.1	32.2	21.0
1	41.4	20.7	41.4	10.9	5.4	10.9	3.80	31.2	15.6	31.2	21.0
0	40.4	20.2	40.4	10.9	5.4	10.9	3.71	30.3	15.1	30.3	21.1
-1	39.5	19.8	39.5	10.9	5.4	10.9	3.63	29.3	14.7	29.3	21.1
-2	38.6	19.3	38.6	10.9	5.4	10.9	3.54	28.4	14.2	28.4	21.1
-3	37.7	18.9	37.7	10.9	5.4	10.9	3.46	27.5	13.8	27.5	21.0
-4	36.8	18.4	36.8	10.9	5.4	10.9	3.38	26.7	13.3	26.7	21.0
-5	36.0	18.0	36.0	10.9	5.4	10.9	3.31	25.8	12.9	25.8	21.0
-6	35.1	17.6	35.1	10.9	5.4	10.9	3.23	25.0	12.5	25.0	21.0
-7	34.3	17.2	34.3	10.9	5.4	10.9	3.16	24.2	12.1	24.2	21.0
-8	33.5	16.7	33.5	10.8	5.3	10.8	3.09	23.4	11.7	23.4	21.0
-9	32.7	16.3	32.7	10.8	5.3	10.8	3.02	22.6	11.3	22.6	21.0
-10	31.9	15.9	31.9	10.8	5.3	10.8	2.95	21.8	10.9	21.8	21.0
-11	31.1	15.6	31.1	10.8	5.3	10.8	2.88	21.0	10.5	21.0	21.0
-12	30.3	15.2	30.3	10.8	5.3	10.8	2.82	20.3	10.1	20.3	20.9
-13	29.6	14.8	29.6	10.7	5.3	10.7	2.75	19.6	9.8	19.6	20.9
-14	28.9	14.4	28.9	10.7	5.3	10.7	2.69	18.8	9.4	18.8	20.9
-15	28.1	14.1	28.1	10.7	5.3	10.7	2.63	18.1	9.1	18.1	20.8

-- Achtung: Betriebsgrenzen beachten - nicht in Tabelle festgehalten

Tws -VL		55										
Twq -RL	Qh nom	Qh min	Qh max	Pin nom	Pin min	Pin max	COP nom	Qc nom	Qc min	Qc max	I nom	
[°C]	[kW]	[kW]	[kW]	[kW]	[kW]	[kW]	kW / kW	[kW]	[kW]	[kW]	[A]	
25	69.4	34.7	69.4	14.0	6.9	14.0	4.96	56.3	28.1	56.3	24.5	
24	68.0	34.0	68.0	14.0	6.9	14.0	4.85	54.9	27.5	54.9	24.6	
23	66.7	33.3	66.7	14.0	6.9	14.0	4.75	53.6	26.8	53.6	24.6	
22	65.4	32.7	65.4	14.1	6.9	14.1	4.65	52.2	26.1	52.2	24.6	
21	64.1	32.0	64.1	14.1	6.9	14.1	4.55	50.9	25.5	50.9	24.6	
20	62.8	31.4	62.8	14.1	7.0	14.1	4.46	49.7	24.8	49.7	24.7	
19	61.6	30.8	61.6	14.1	7.0	14.1	4.36	48.4	24.2	48.4	24.7	
18	60.4	30.2	60.4	14.1	7.0	14.1	4.27	47.2	23.6	47.2	24.7	
17	59.2	29.6	59.2	14.2	7.0	14.2	4.18	45.9	23.0	45.9	24.7	
16	58.0	29.0	58.0	14.2	7.0	14.2	4.09	44.7	22.4	44.7	24.7	
15	56.8	28.4	56.8	14.2	7.0	14.2	4.01	43.6	21.8	43.6	24.8	
14	55.7	27.8	55.7	14.2	7.0	14.2	3.92	42.4	21.2	42.4	24.8	
13	54.6	27.3	54.6	14.2	7.0	14.2	3.84	41.3	20.6	41.3	24.8	
12	53.4	26.7	53.4	14.2	7.0	14.2	3.76	40.2	20.1	40.2	24.8	
11	52.4	26.2	52.4	14.2	7.0	14.2	3.68	39.1	19.5	39.1	24.8	
10	51.3	25.6	51.3	14.2	7.0	14.2	3.60	38.0	19.0	38.0	24.8	
9	50.2	25.1	50.2	14.2	7.0	14.2	3.53	36.9	18.5	36.9	24.8	
8	49.2	24.6	49.2	14.2	7.0	14.2	3.45	35.9	18.0	35.9	24.8	
7	48.2	24.1	48.2	14.2	7.0	14.2	3.38	34.9	17.4	34.9	24.8	
6	47.2	23.6	47.2	14.2	7.0	14.2	3.31	33.9	16.9	33.9	24.8	
5	46.2	23.1	46.2	14.2	7.0	14.2	3.24	32.9	16.4	32.9	24.8	
4	45.2	22.6	45.2	14.2	7.0	14.2	3.18	31.9	16.0	31.9	24.8	
3	44.3	22.1	44.3	14.2	7.0	14.2	3.11	31.0	15.5	31.0	24.8	
2	43.3	21.7	43.3	14.2	7.0	14.2	3.05	30.1	15.0	30.1	24.8	
1	42.4	21.2	42.4	14.2	7.0	14.2	2.99	29.1	14.6	29.1	24.8	
0	41.5	20.7	41.5	14.2	7.0	14.2	2.92	28.2	14.1	28.2	24.8	
-1	40.6	20.3	40.6	14.2	7.0	14.2	2.86	27.4	13.7	27.4	24.7	
-2	39.7	19.9	39.7	14.2	7.0	14.2	2.81	26.5	13.2	26.5	24.7	
-3	38.8	19.4	38.8	14.1	7.0	14.1	2.75	25.7	12.8	25.7	24.7	
-4	38.0	19.0	38.0	14.1	7.0	14.1	2.69	24.8	12.4	24.8	24.7	
-5	37.1	18.6	37.1	14.1	6.9	14.1	2.64	24.0	12.0	24.0	24.6	
-6	36.3	18.2	36.3	14.0	6.9	14.0	2.59	23.2	11.6	23.2	24.6	
-7	35.5	17.7	35.5	14.0	6.9	14.0	2.53	22.4	11.2	22.4	24.6	
-8	34.7	17.3	34.7	14.0	6.9	14.0	2.48	21.6	10.8	21.6	24.5	
-9	33.9	16.9	33.9	13.9	6.9	13.9	2.43	20.9	10.4	20.9	24.5	
-10	33.1	16.5	33.1	13.9	6.8	13.9	2.39	20.1	10.1	20.1	24.4	
-11	32.3	16.2	32.3	13.8	6.8	13.8	2.34	19.4	9.7	19.4	24.4	
-12	31.5	15.8	31.5	13.8	6.8	13.8	2.29	18.7	9.3	18.7	24.3	
-13	30.8	15.4	30.8	13.7	6.8	13.7	2.25	18.0	9.0	18.0	24.2	
-14	30.0	15.0	30.0	13.7	6.7	13.7	2.20	17.3	8.6	17.3	24.2	
-15	29.3	14.7	29.3	13.6	6.7	13.6	2.16	16.6	8.3	16.6	24.1	

-- Achtung: Betriebsgrenzen beachten - nicht in Tabelle festgehalten

Tws -VL	65 (T-max)										
	[°C]	Qh nom	Qh min	Qh max	Pin nom	Pin min	Pin max	COP nom	Qc nom	Qc min	Qc max
[°C]	[kW]	[kW]	[kW]	[kW]	[kW]	[kW]	kW / kW	[kW]	[kW]	[kW]	[A]
25	69.6	34.8	69.6	18.4	9.1	18.4	3.78	52.4	26.2	52.4	30.1
24	68.3	34.2	68.3	18.4	9.1	18.4	3.71	51.1	25.6	51.1	30.1
23	67.1	33.5	67.1	18.5	9.1	18.5	3.63	49.8	24.9	49.8	30.1
22	65.8	32.9	65.8	18.5	9.1	18.5	3.56	48.6	24.3	48.6	30.2
21	64.6	32.3	64.6	18.5	9.1	18.5	3.50	47.4	23.7	47.4	30.2
20	63.4	31.7	63.4	18.5	9.1	18.5	3.43	46.2	23.1	46.2	30.2
19	62.3	31.1	62.3	18.5	9.1	18.5	3.36	45.0	22.5	45.0	30.2
18	61.1	30.6	61.1	18.5	9.1	18.5	3.30	43.8	21.9	43.8	30.2
17	60.0	30.0	60.0	18.5	9.1	18.5	3.24	42.7	21.3	42.7	30.2
16	58.9	29.4	58.9	18.5	9.1	18.5	3.17	41.6	20.8	41.6	30.2
15	57.8	28.9	57.8	18.5	9.1	18.5	3.11	40.5	20.2	40.5	30.2
14	56.7	28.3	56.7	18.5	9.1	18.5	3.06	39.4	19.7	39.4	30.2
13	55.6	27.8	55.6	18.5	9.1	18.5	3.00	38.3	19.1	38.3	30.2
12	54.6	27.3	54.6	18.5	9.1	18.5	2.94	37.3	18.6	37.3	30.2
11	53.5	26.8	53.5	18.5	9.1	18.5	2.89	36.2	18.1	36.2	30.2
10	52.5	26.3	52.5	18.5	9.1	18.5	2.83	35.2	17.6	35.2	30.2
9	51.5	25.8	51.5	18.5	9.1	18.5	2.78	34.2	17.1	34.2	30.2
8	50.5	25.3	50.5	18.5	9.1	18.5	2.73	33.2	16.6	33.2	30.2
7	49.5	24.8	49.5	18.5	9.1	18.5	2.68	32.3	16.1	32.3	30.2
6	48.6	24.3	48.6	18.5	9.1	18.5	2.63	31.3	15.7	31.3	30.1
5	47.6	23.8	47.6	18.4	9.1	18.4	2.58	30.4	15.2	30.4	30.1
4	46.7	23.3	46.7	18.4	9.1	18.4	2.54	29.5	14.7	29.5	30.1
3	45.8	22.9	45.8	18.4	9.1	18.4	2.49	28.6	14.3	28.6	30.0
2	44.9	22.4	44.9	18.3	9.0	18.3	2.45	27.7	13.9	27.7	30.0
1	44.0	22.0	44.0	18.3	9.0	18.3	2.40	26.9	13.4	26.9	29.9
0	43.1	21.5	43.1	18.3	9.0	18.3	2.36	26.0	13.0	26.0	29.9
-1	42.2	21.1	42.2	18.2	9.0	18.2	2.32	25.2	12.6	25.2	29.8
-2	41.3	20.7	41.3	18.2	9.0	18.2	2.27	24.4	12.2	24.4	29.8
-3	40.5	20.2	40.5	18.1	8.9	18.1	2.23	23.6	11.8	23.6	29.7
-4	39.6	19.8	39.6	18.1	8.9	18.1	2.19	22.8	11.4	22.8	29.6
-5	38.8	19.4	38.8	18.0	8.9	18.0	2.16	22.0	11.0	22.0	29.6
-6	38.0	19.0	38.0	17.9	8.8	17.9	2.12	21.2	10.6	21.2	29.5
-7	37.1	18.6	37.1	17.9	8.8	17.9	2.08	20.5	10.2	20.5	29.4
-8	36.3	18.2	36.3	17.8	8.8	17.8	2.04	19.7	9.9	19.7	29.3
-9	35.5	17.8	35.5	17.7	8.7	17.7	2.01	19.0	9.5	19.0	29.2
-10	34.7	17.4	34.7	17.6	8.7	17.6	1.97	18.3	9.1	18.3	29.1
-11	34.0	17.0	34.0	17.5	8.6	17.5	1.94	17.6	8.8	17.6	29.0
-12	33.2	16.6	33.2	17.4	8.6	17.4	1.90	16.9	8.5	16.9	28.9
-13	32.4	16.2	32.4	17.3	8.5	17.3	1.87	16.2	8.1	16.2	28.8
-14	31.7	15.8	31.7	17.2	8.5	17.2	1.84	15.6	7.8	15.6	28.7
-15	30.9	15.5	30.9	17.1	8.4	17.1	1.81	14.9	7.5	14.9	28.6

-- Achtung: Betriebsgrenzen beachten - nicht in Tabelle festgehalten

Tk -VL	W 12 / 7 °C										
[°C]	Qc nom [kW]	Qc min [kW]	Qc max [kW]	Pin nom [kW]	Pin min [kW]	Pin max [kW]	EER kW / kW	Qh nom [kW]	Qh min [kW]	Qh max [kW]	I nom [A]
40	28.7	14.4	28.7	11.9	5.9	11.9	2.42	39.8	19.9	39.8	22.1
39	28.9	14.5	28.9	11.6	5.7	11.6	2.49	39.7	19.9	39.7	21.8
38	29.1	14.5	29.1	11.3	5.6	11.3	2.57	39.6	19.8	39.6	21.5
37	29.3	14.6	29.3	11.0	5.4	11.0	2.65	39.6	19.8	39.6	21.2
36	29.4	14.7	29.4	10.8	5.3	10.8	2.73	39.5	19.7	39.5	20.9
35	29.6	14.8	29.6	10.5	5.2	10.5	2.82	39.4	19.7	39.4	20.6
34	29.8	14.9	29.8	10.2	5.1	10.2	2.91	39.3	19.7	39.3	20.4
33	29.9	15.0	29.9	10.0	4.9	10.0	2.99	39.3	19.6	39.3	20.1
32	30.1	15.0	30.1	9.8	4.8	9.8	3.08	39.2	19.6	39.2	19.9
31	30.3	15.1	30.3	9.5	4.7	9.5	3.18	39.1	19.6	39.1	19.6
30	30.4	15.2	30.4	9.3	4.6	9.3	3.27	39.1	19.5	39.1	19.4
29	30.6	15.3	30.6	9.1	4.5	9.1	3.37	39.0	19.5	39.0	19.2
28	30.7	15.4	30.7	8.9	4.4	8.9	3.46	39.0	19.5	39.0	19.0
27	30.9	15.4	30.9	8.7	4.3	8.7	3.56	38.9	19.5	38.9	18.8
26	31.0	15.5	31.0	8.5	4.2	8.5	3.67	38.9	19.5	38.9	18.6
25	31.2	15.6	31.2	8.3	4.1	8.3	3.77	38.9	19.4	38.9	18.4
24	31.3	15.6	31.3	8.1	4.0	8.1	3.87	38.8	19.4	38.8	18.2
23	31.4	15.7	31.4	7.9	3.9	7.9	3.98	38.8	19.4	38.8	18.1
22	31.6	15.8	31.6	7.7	3.8	7.7	4.09	38.8	19.4	38.8	17.9
21	31.7	15.8	31.7	7.5	3.7	7.5	4.20	38.7	19.4	38.7	17.7
20	31.8	15.9	31.8	7.4	3.6	7.4	4.31	38.7	19.4	38.7	17.6

Tc [°C]	W 23 / 18 °C										
[°C]	Qc nom [kW]	Qc min [kW]	Qc max [kW]	Pin nom [kW]	Pin min [kW]	Pin max [kW]	EER kW / kW	Qh nom [kW]	Qh min [kW]	Qh max [kW]	I nom [A]
40	38.6	19.3	38.6	11.9	5.9	11.9	3.25	49.7	24.9	50.5	22.1
39	38.9	19.4	38.9	11.6	5.7	11.6	3.35	49.7	24.8	50.4	21.8
38	39.1	19.6	39.1	11.3	5.6	11.3	3.46	49.6	24.8	50.3	21.4
37	39.3	19.7	39.3	11.0	5.4	11.0	3.56	49.6	24.8	50.2	21.1
36	39.5	19.8	39.5	10.8	5.3	10.8	3.67	49.5	24.8	50.1	20.8
35	39.8	19.9	39.8	10.5	5.2	10.5	3.79	49.5	24.7	50.1	20.6
34	40.0	20.0	40.0	10.2	5.1	10.2	3.90	49.5	24.7	50.0	20.3
33	40.2	20.1	40.2	10.0	4.9	10.0	4.02	49.4	24.7	49.9	20.0
32	40.4	20.2	40.4	9.8	4.8	9.8	4.14	49.4	24.7	49.8	19.8
31	40.6	20.3	40.6	9.5	4.7	9.5	4.26	49.4	24.7	49.8	19.5
30	40.8	20.4	40.8	9.3	4.6	9.3	4.39	49.4	24.7	49.7	19.3
29	41.0	20.5	41.0	9.1	4.5	9.1	4.52	49.4	24.7	49.7	19.1
28	41.2	20.6	41.2	8.9	4.4	8.9	4.65	49.4	24.7	49.6	18.9
27	41.4	20.7	41.4	8.7	4.3	8.7	4.78	49.4	24.7	49.6	18.7
26	41.6	20.8	41.6	8.5	4.2	8.5	4.91	49.4	24.7	49.5	18.5
25	41.7	20.9	41.7	8.3	4.1	8.3	5.05	49.4	24.7	49.5	18.3
24	41.9	21.0	41.9	8.1	4.0	8.1	5.19	49.4	24.7	49.5	18.2
23	42.1	21.1	42.1	7.9	3.9	7.9	5.33	49.4	24.7	49.4	18.0
22	42.3	21.1	42.3	7.7	3.8	7.7	5.48	49.4	24.7	49.4	17.9
21	42.4	21.2	42.4	7.5	3.7	7.5	5.62	49.5	24.7	49.4	17.7
20	42.6	21.3	42.6	7.4	3.6	7.4	5.77	49.5	24.7	49.4	17.6

-- Achtung: Betriebsgrenzen beachten - nicht in Tabelle festgehalten

LEGENDE:

T_{wq-RL}: Temperatur Wärmequelle - Eintritt [°C]

T_{ws-VL}: Temperatur Wärmesenke - Vorlauf [°C]

T_{k-VL}: Temperatur Kältesenke - Vorlauf [°C]

Q_{h nom}: Heizleistung nominal

Q_{h min}: Heizleistung minimal

Q_{h max}: Heizleistung maximal

P_{in nom}: Aufnahme bei nominaler Heizleistung

P_{in min}: Aufnahme bei minimaler Heizleistung

P_{in max}: Aufnahme bei maximaler Heizleistung

COP nom: Arbeitszahl bei nominaler Heizleistung

Q_{c nom}: Kälteleistung/Energieentnahme bei nominaler Heizleistung

Q_{c min}: Kälteleistung/Energieentnahme bei minimaler Heizleistung

Q_{c max}: Kälteleistung/Energieentnahme bei maximaler Heizleistung

I nom: Stromaufnahme bei nominaler Heizleistung

EER: Arbeitszahl bei nominaler Kälteleistung

Betriebsgrenzen

Temp °C

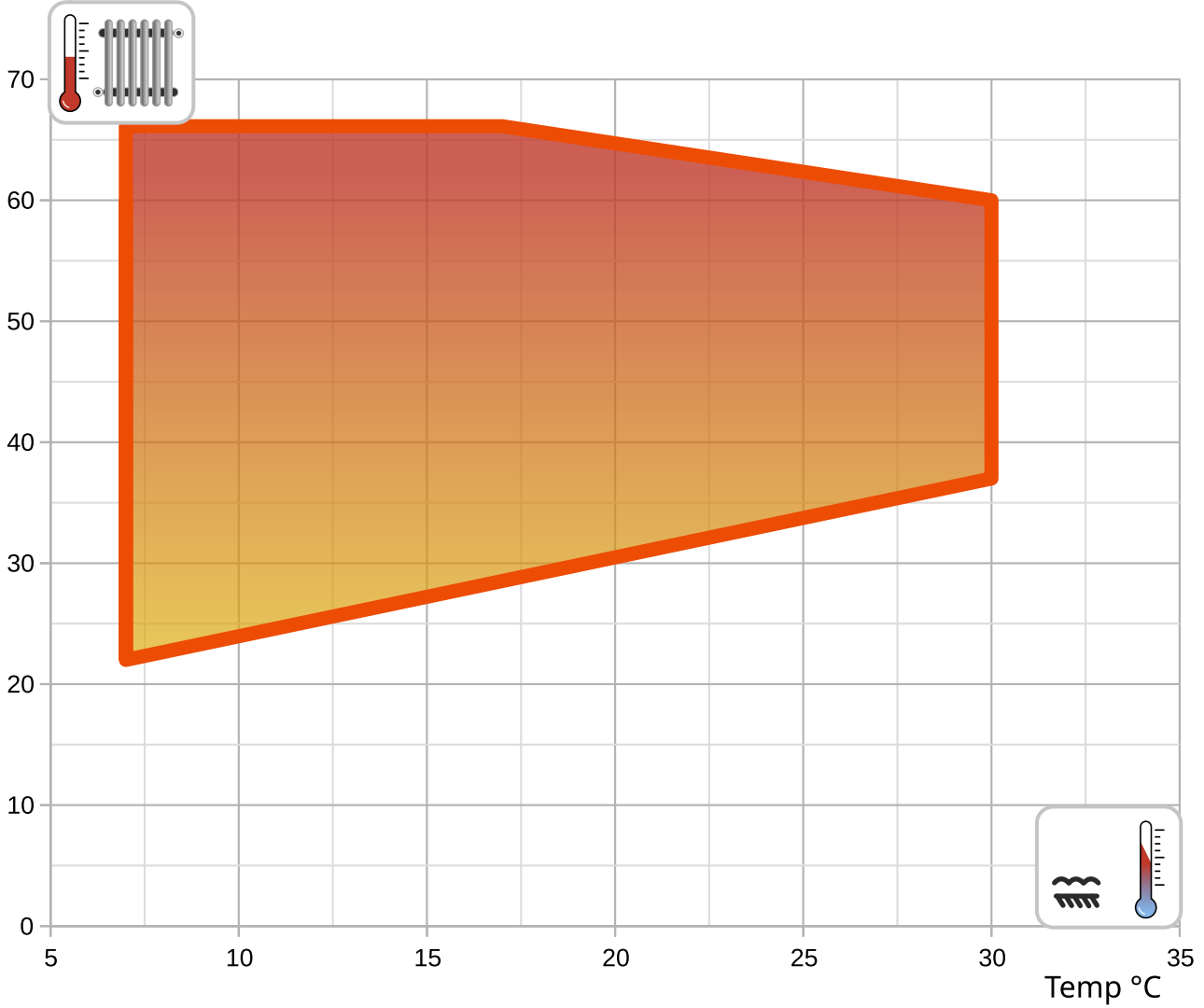

Temp °C

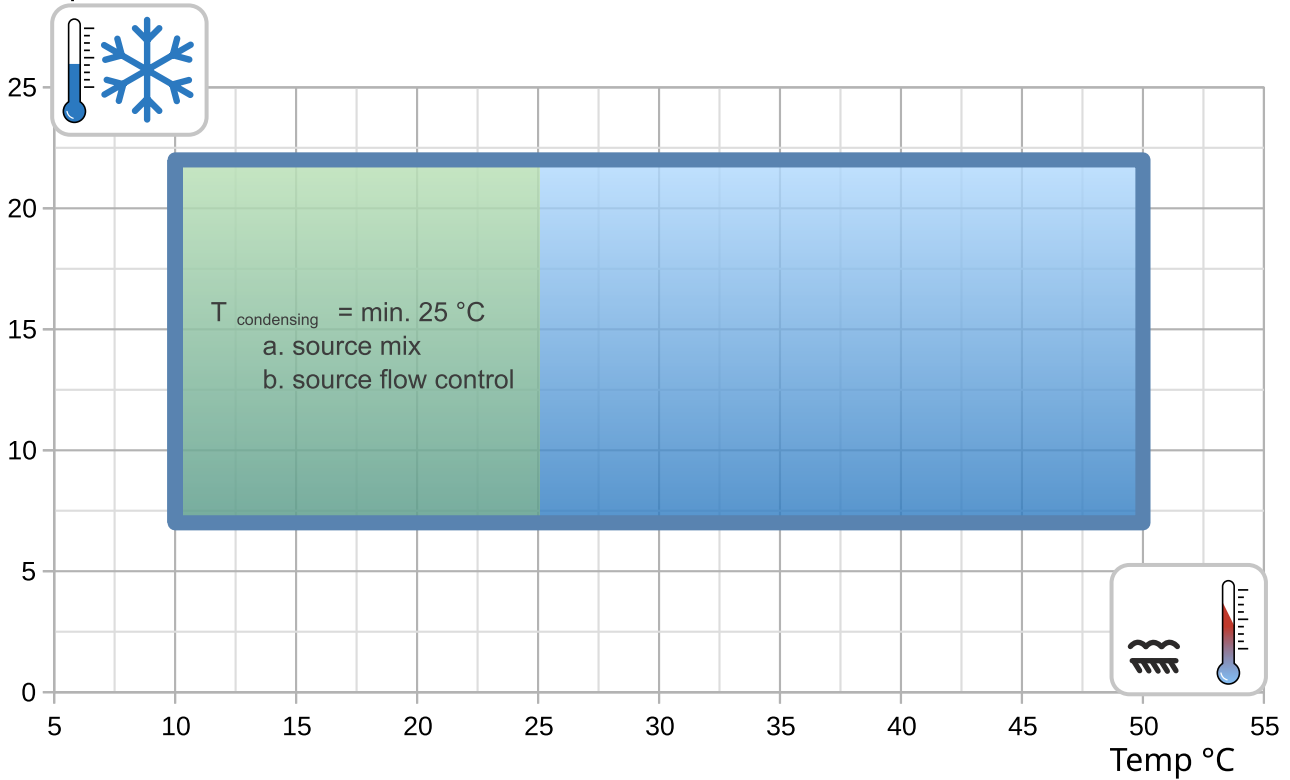

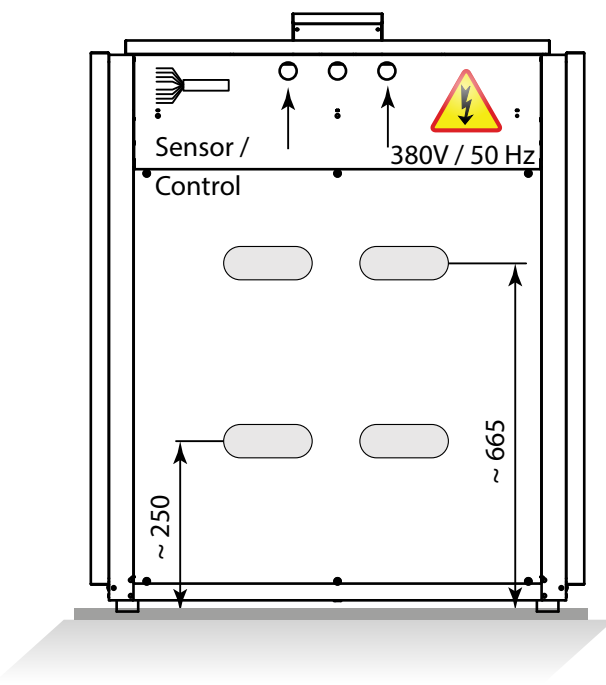
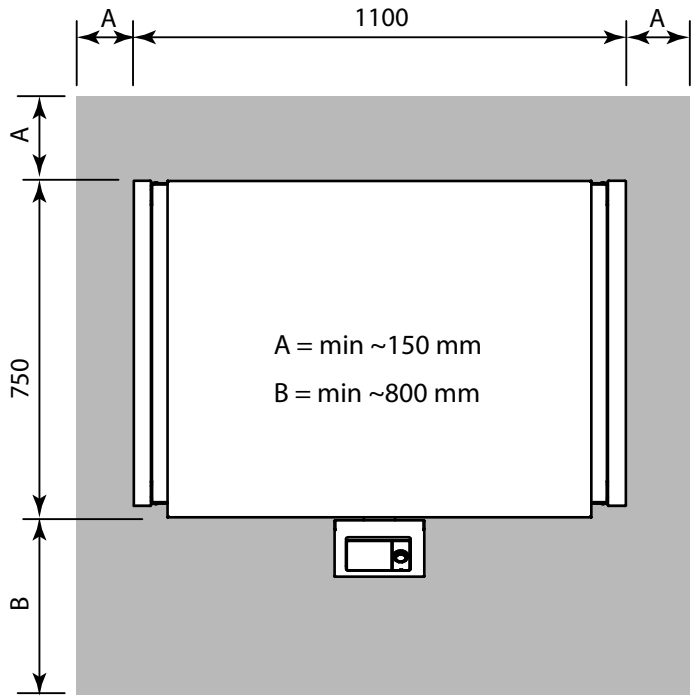
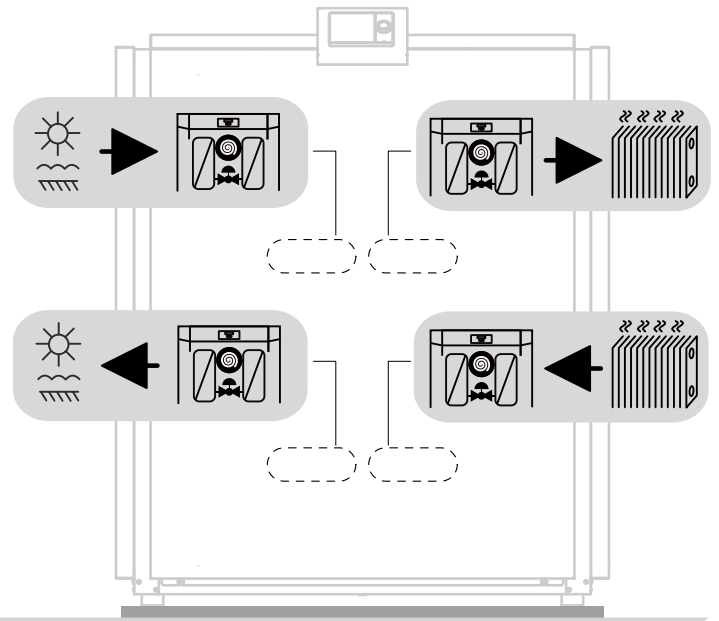
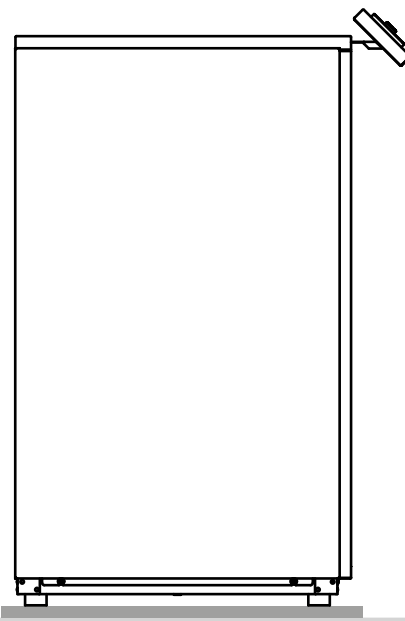
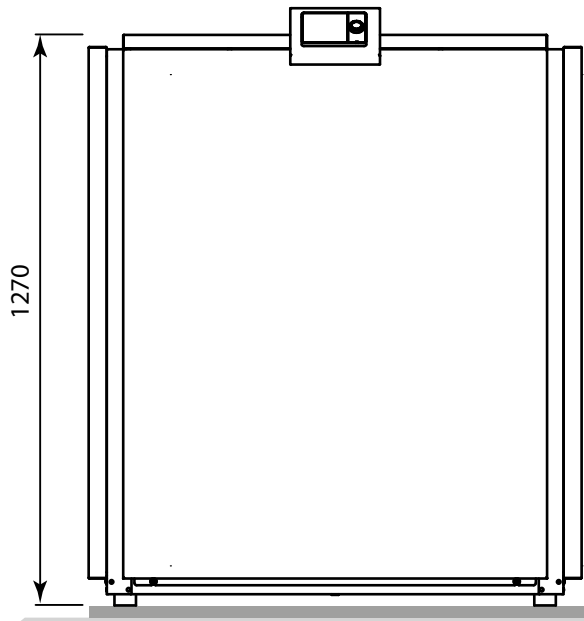

int. code: VN1100

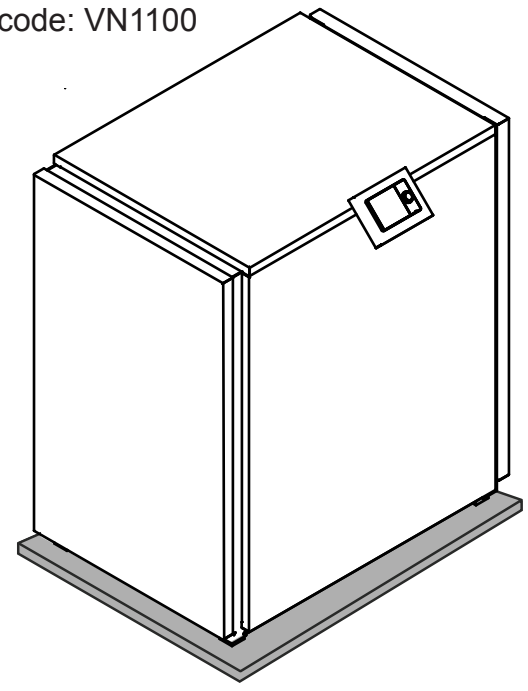

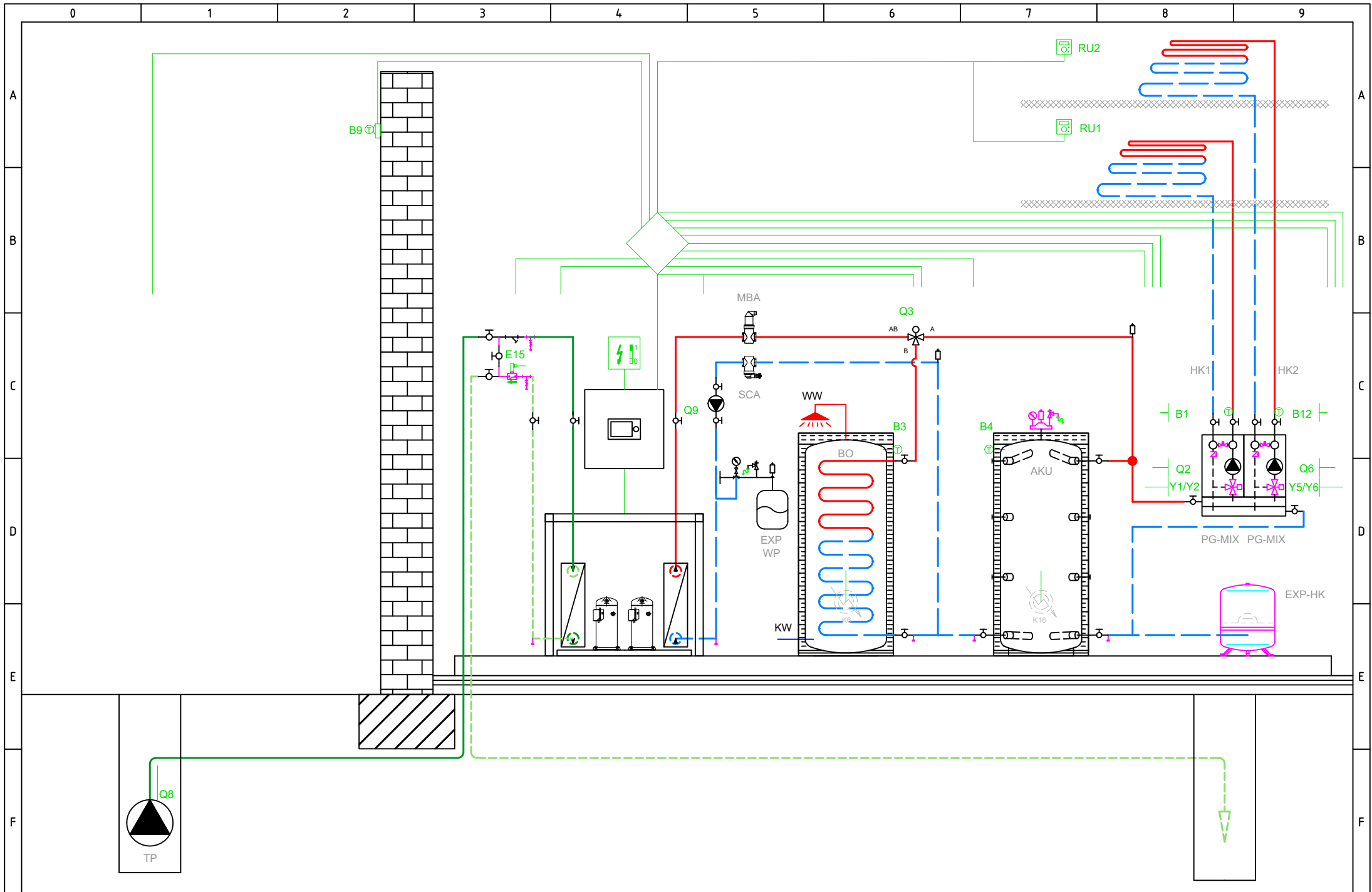

BASIC APPLICATION

Total: max 6A
1 x QX...: max 2A

Netzanschluss 230V / 50 Hz
Erde
Nullleiter

- E9 Niederdruckwächter E9
- E10 Hochdruckwächter E10
- E15 Ström'wächter Quelle E15
- E24 Ström'wächter Verbrau E24
- E6 EW Sperre E6
- E12 Überlast Verdichter 2 E12
- E21 Drehstrom E21
- E22 Drehstrom E22
- E23 Drehstrom E23
- E11 Überlast Verdichter 1 E11
- K1 Verdichterstufe 1 K1

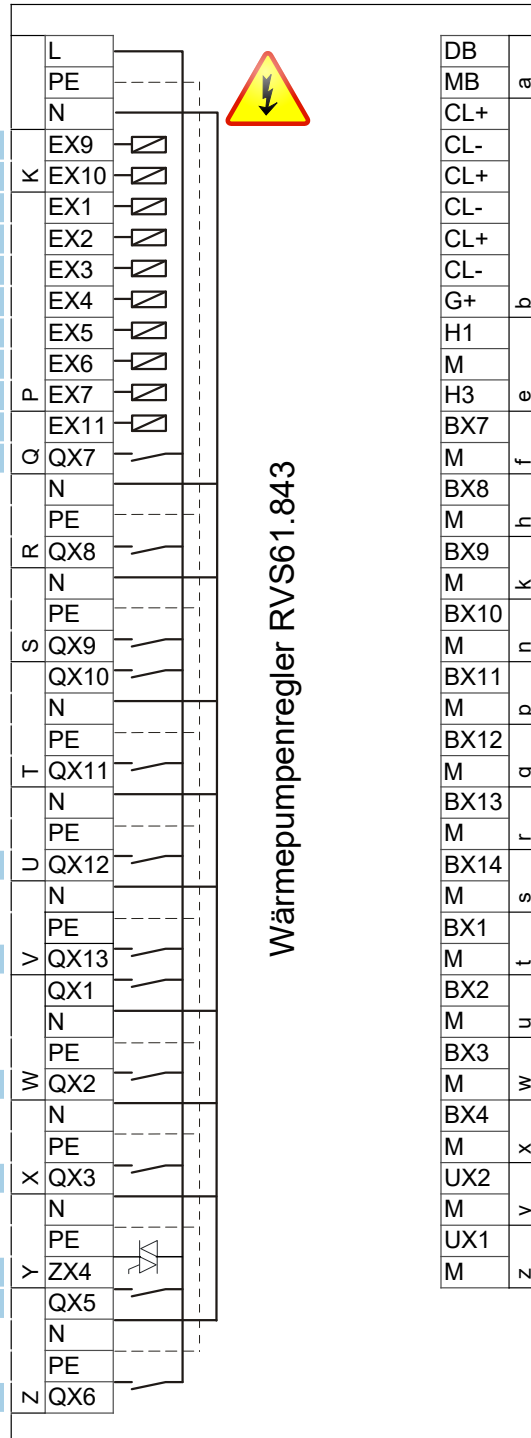

Wärmepumpenregler RVS61.843

Q8 Quellpumpe Q8

Q9 Kondensatorpumpe Q9

K10 Alarmausgang K10

K40 Ölumpfheizung K40

K81 Ventil Verdampfer K81

K82 Ventil EVI K82

K2 Verdichterstufe 2 K2

DB		LPB Bus Data
MB	a	LPB Bus Masse
CL+		Raumgerät QAA...
CL-		Raumgerät QAA... 2.
CL+		Raumgerät QAA... 2.
CL-		Raumgerät QAA... 2.
CL+		Raumgerät QAA... 3.
CL-		Raumgerät QAA... 3.
G+	b	12V Versorgung → AUS
H1		
M		
H3	e	Verbr'anforderung VK1
BX7		B81 Heissgasfühler K1 B81
M	f	
BX8		
M	h	
BX9		
M	k	
BX10		B21 WP Vorlauffühler B21
M	n	
BX11		
M	p	
BX12		B71 WP Rücklauffühler B71
M	q	
BX13		B91 Quelleneintrittfühler B91
M	r	
BX14		B84 Quellenaust'fühler B92/B84
M	s	
BX1		
M	t	
BX2		
M	u	
BX3		B83 Kältemittelfühler flüssig B83
M	w	
BX4		B82 Heissgasfühler K2 B82
M	x	
UX2		Kondensatorpumpe Q9
M	y	0..10V Analogsignal
UX1		Quell'pumpe Q8
M	z	0..10V Analogsignal



- AVS75.390
- AVS75.391
- AVS75.370

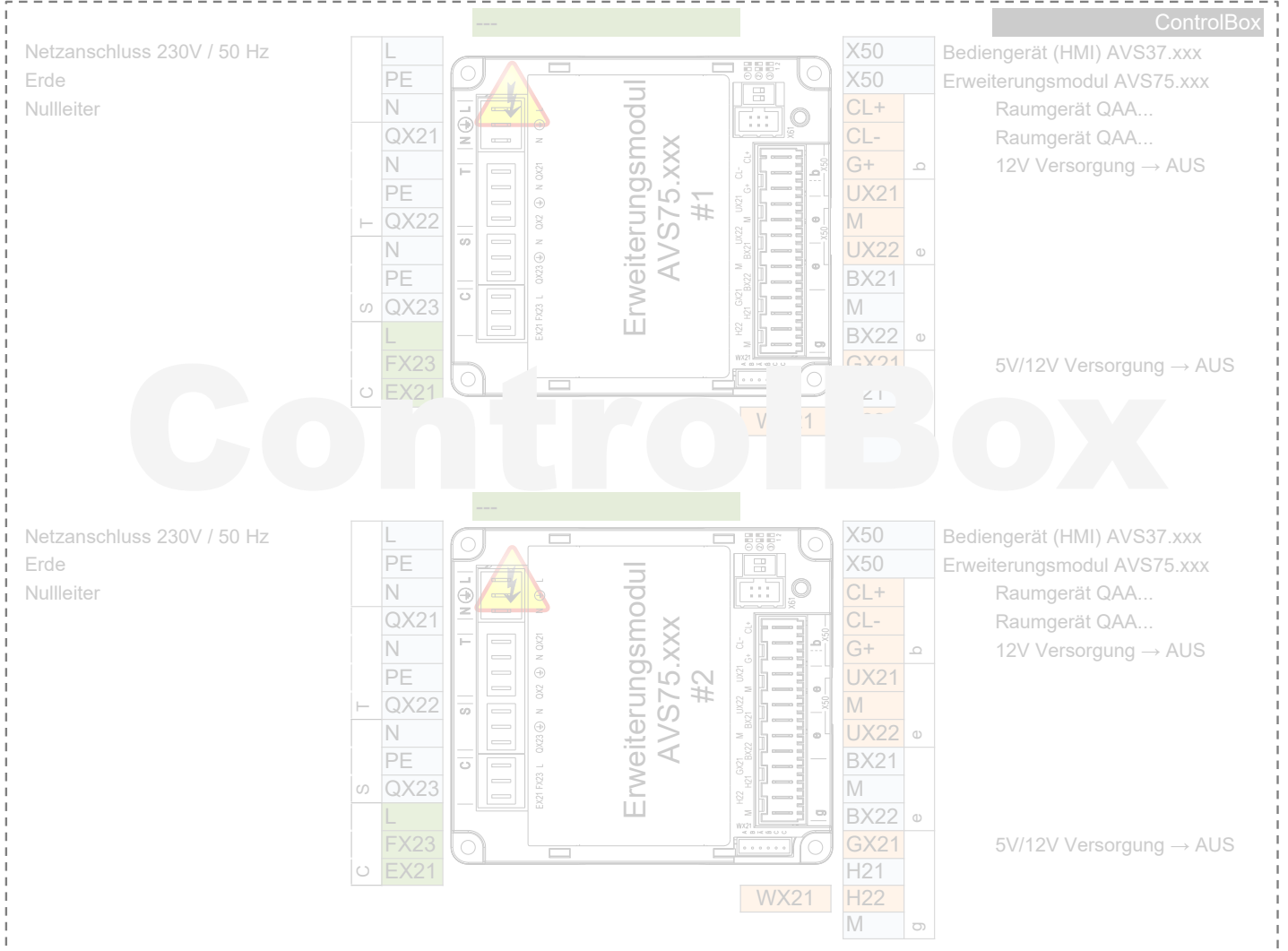

HEAT PUMP

EXTERNAL
INTERNAL



K1

K2

K82

K81

K40

K10

Q8 UX1

Q9 UX2

E11
KRW1
F1K
E11

E12
KRW2
F2K
E12

E6

Q9 ERR
F1S
E24

Q8.ERR
F1Z
E15

E10
E9

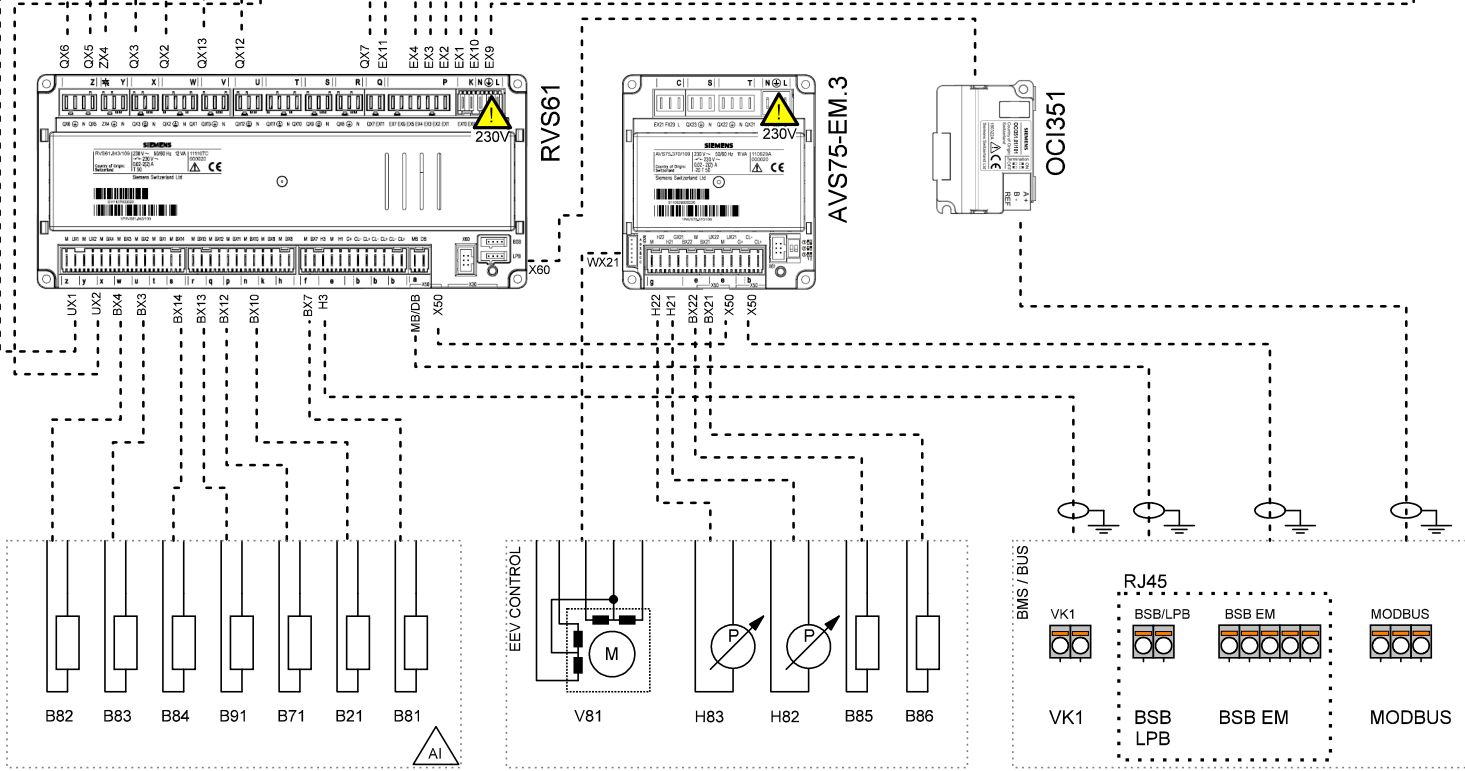
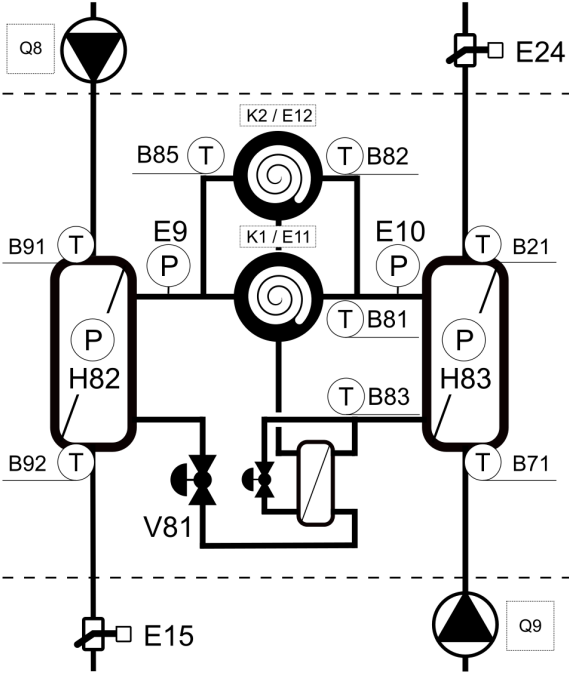
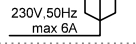
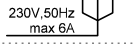
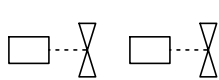

PWR SPLY: 3~ 400V, 50 Hz
CTRL: 1~ 230V, 50 HZ

Company	Title	Version / Note	Number	Created by	Date	Page
	TBW-TWW	05/2024				1



Company	Title	Version / Note	Number	Created by	Date	Page
	CONTROL BOX	05/2024				1



Company	Title	Version / Note	Number	Created by	Date	Page
	CONTROL BOX	05/2024				2



Company	Title	Version / Note	Number	Created by	Date	Page
	CONTROL BOX	05/2024				3





- AVS75.390
- AVS75.391
- AVS75.370

- AVS75.370**
 Netzanschluss 230V / 50 Hz
 Erde
 Nullleiter
Y1 Mischer Auf

Y2 Mischer Zu

Q2 Heizkreispumpe HK1 Q2

L Faze 230V
E61 Smart Grid E61

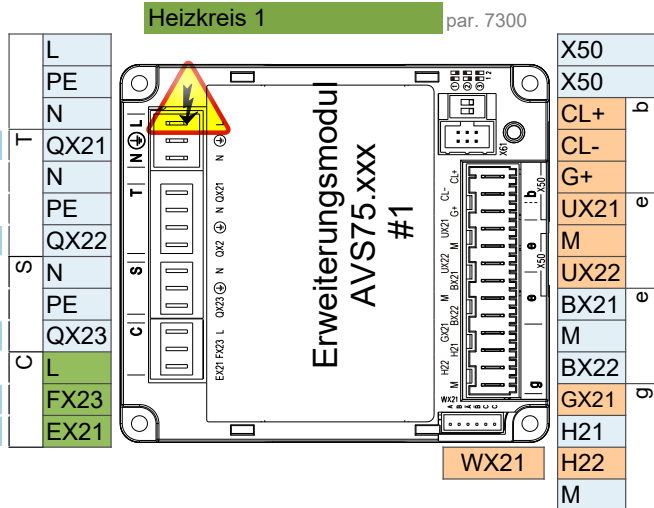

- Erweiterungsmodul AVS75.xxx
 Raumgerät QAA...
 Raumgerät QAA...

B1 Vorlauffühler 1

Impulszählung

- AVS75.370**
 Netzanschluss 230V / 50 Hz
 Erde
 Nullleiter
Q3 Trinkwasserstellglied Q3

K6 Elektroeinsatz TWW K6

Q6 Heizkreispumpe HK2 Q6

L Faze 230V
E62 Smart Grid E62

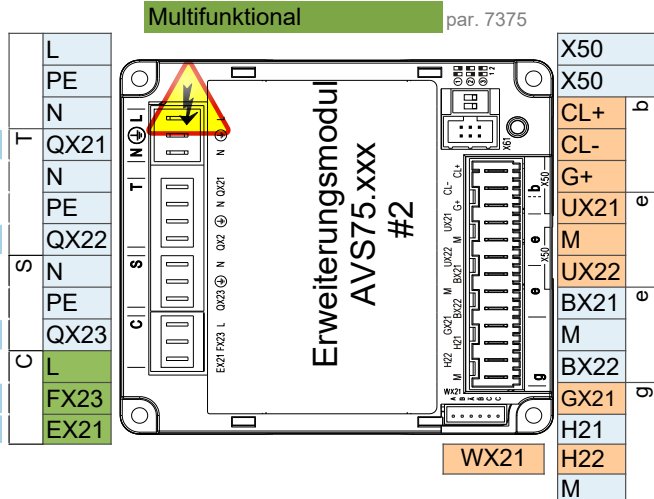

- Bediengerät (HMI) AVS37.xxx
 Erweiterungsmodul AVS75.xxx
 Raumgerät QAA...
 Raumgerät QAA...

B3 Trinkwasserfühler B3

B4 Pufferspeicherfühler B4

- Netzanschluss 230V / 50 Hz
 Erde
 Nullleiter

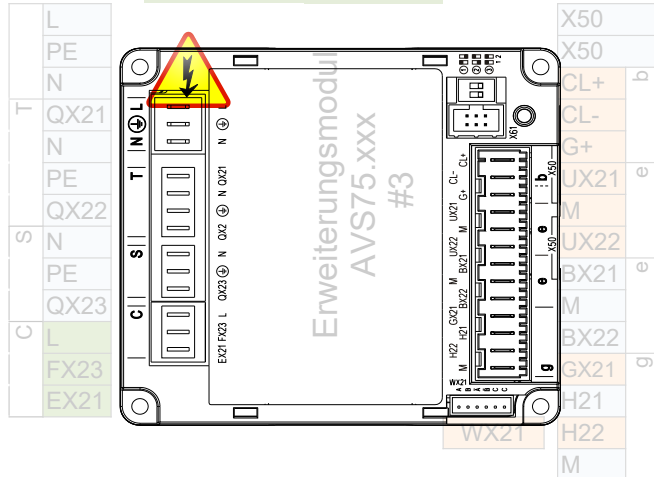

- Bediengerät (HMI) AVS37.xxx
 Erweiterungsmodul AVS75.xxx
 Raumgerät QAA...
 Raumgerät QAA...

Vorsicht: Erweiterungsmodul 3 ist in der Wärmepumpe

Anschlussmöglichkeiten für die Steuerung

1 ControlBox

ControlBox, mit zwei eingebauten Erweiterungsmodulen, ermöglicht zahlreiche Optionen für die Anwendungssteuerung auf der Verbraucherseite hinter der Wärmepumpe. Weitere Informationen finden Sie im Schaltplan der ControlBox und im Blatt mit den Anwendungsdiagrammen.

2 Fixer Sollwert Vorlauftemperatur - Ein / Aus potentialfreier Kontakt

2-adriges abgeschirmtes Kabel 2 x 0,5 mm² - Sollwert = 45°C (editierbar über Parameter 1859)

Anschlussklemme - siehe Schaltplan

3 Analog 0..10V Vorlauftemperatur-Sollwertregelung

2 Adern geschirmtes Kabel 2 x 0,5 mm² - Sollwert: 0V = 16°C ~ 10V = 60°C (editierbar im Parametersatz)

Anschlussklemme - siehe Schaltplan

4 ModBus RTU-Kommunikationsbefehl

3-adriges abgeschirmtes Kabel min. 3 x 0,25mm²

Für die ModBus-Zuordnungstabelle wenden Sie sich bitte an den technischen Support

5 MQTT IoT-Kommunikationsprotokoll

Für weitere Informationen wenden Sie sich bitte an den technischen Support