

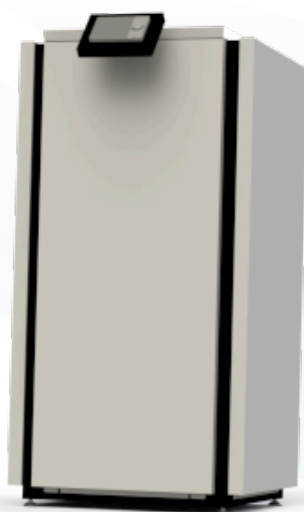

Heat pump



BW 14 EVI

WAMAK BW 14 EVI

Product description

Compact heat pump for heating and domestic hot water with passive cooling control. Short closed refrigerant circuit with silent scroll compressor contributes to long-term stable operation.

Use for single-family houses and smaller buildings with a heat output requirement of up to 20 kW. The COMFORT range includes robust heat pump internal refrigerant circuit parts as well as all the measuring, distribution and control elements required by today's modern climate technology in single-family houses.

As a primary source, the thermal energy of the sun accumulated in the ground through a horizontal collector or geothermal energy through a deep borehole is used. In the collector or borehole, an antifreeze flows which takes the energy of the earth at a low temperature and the heat pump raises this temperature to a temperature usable for heating or hot water.

The EVI (Enhanced Vapour Injection) technology allows the heat pump to achieve higher header flow temperatures even at lower source temperatures. EVI also has a positive impact on the compressor lifespan and overall system stability because the discharge gas temperature from the compressor is lower.

Product features

- Scroll compressor
- EVI technology
- Asymmetric plate heat exchanger
- Phase and rotation control
- High pressure sensor - analogue
- Flow switch consumer - on/off - (with accessory)
- Flow switch source - on/off - (with accessory)
- ECM speed circulator - evaporator
- Direct heating/cooling circuit control
- DHW circulation control
- DHW temperature sensor
- Cascade control - (with accessory)
- Solid frame structure
- Sylomer pads under compressor unit
- Electronic expansion valve
- Compressor soft starter
- High pressure switch
- Low pressure sensor - analogue
- Flow sensor consumer - analogue
- ECM speed circulator - condenser
- Mixed heating/cooling circuit control
- DHW switching control
- Outdoor temperature sensor
- Buffer temperature sensor
- Modbus connection - (with accessory)

Basic performance data - WAMAK BW 14 EVI

Heating - EN 14511		
Heating capacity [kW]	B0 / W35 (max)	14.5
	B0 / W35 (min)	14.5
	B0 / W34	14.4
Electrical power input [kW]	B0 / W35 (max)	3.1
	B0 / W35 (min)	3.1
	B0 / W34	3.0
Heating efficiency faktor [COP]	B0 / W35 (max)	4.63
	B0 / W35 (min)	4.63
	B0 / W34	4.74
Seasonal space heating energy efficiency - SCOP EN 14825		
Average Climate / Low Temperature [35 °C]	SCOP	5.29
	η [%]	211.4
	Label	A+++
	Qhe [kWh]	5627.5
	Pdesignh [kW]	14.5
	Tbivalent [°C]	-10
Cooling		
Cooling capacity - [kW]	A35 / W23-18	14.8
	A25 / W23-18	15.8
	A35 / W12-7	14.8
	A25 / W12-7	14.8
Seasonal space cooling energy efficiency - SEER EN 14825		
[W 23 / 18 °C]	SEER	5.58
	Qce [kWh]	1479.7
	η_c [%]	223.3
Sound EN 12102		
Acoustic power - Lw	dB(A)	45.2
Acoustic pressure - Lp	1 m dB(A)	37.2
	5 m dB(A)	23.2
	10 m dB(A)	17.2
Mechanical and operational information		
Compressor type (3~ 400/50)	SCROLL / 1 /	On/Off
Refrigerant	R410A (GWP - 2088)	2.4 kg
Operating limit temperatures heating - (min / max) [°C]		25 / 65
Operating limit temperatures source - (min / max) [°C]		-10 (7) / 30
Weight		155 kg

Main technical data - WAMAK BW 14 EVI

Enclosure type			VN600			Heat energy rejection side data					
Basic dimensions	Height [mm]	1270	Operating limit temperatures heating	MAX [°C]	65	for more see operating limits diagram	Condenser	Port size	1.1/4 "		
	Width [mm]	650		MIN [°C]	25			Type	BPHE		
	Length [mm]	630		Count	1			Material	AISI 316		
Weight [kg]	155		Maximal operating pressure - refrigerant [bar]	45		for more see operating limits diagram	Evaporator	Port size	1.1/4 "		
Colour	Gray		Maximal operating pressure - Water [bar]	6				Type	BPHE		
Enclosure IP Class	IP20		Testing pressure [bar]	70				Count	1		
Refrigeration cycle			Heat transfer medium	Water		for more see operating limits diagram	ECM speed circulator - evaporator	Material	AISI 316		
Compressor	Type	Scroll	Volume flow @ dT 5K (nom) - Water [m3/h]	2.50				for more see operating limits diagram	UPM3 25-75	Maximal operating pressure - refrigerant [bar]	45
	Number of stages	1	Internal pressure drop - Water [kPa]	12						for more see operating limits diagram	Flow sensor consumer - analogue
	On/Off		ECM speed circulator - condenser	UPM3 25-75		for more see operating limits diagram	Temperature difference				
	Power factor Cosφ	0.77	Flow sensor consumer - analogue	0..10V				@ 35°C (nom)	5 K		
	Winding resistance	2.33 Ohm	Temperature difference	@ 55°C	8 K			@ 65°C	10 K		
Refrigerant		R410A	Renewable energy extraction side data			for more see operating limits diagram	Operating limit temperatures source	MIN [°C]	-10 (7)		
		Volme	2.4 kg		for more see operating limits diagram			MAX [°C]	30		
		GWP	2088						for more see operating limits diagram	Evaporator	Port size
		Safety class	A1			for more see operating limits diagram	Type				Count
Refrigeration oil type		POE RL32-3MAF	for more see operating limits diagram	Material	AISI 316			Maximal operating pressure - refrigerant [bar]			28
		Oil volume						1.24 L		Heat transfer medium	Ethylenglykol
Maximal pressure - refrigerant [bar]	45					for more see operating limits diagram	Brine proportion [%]	29	Antifreeze to [°C]	-15	
		PED class	1		for more see operating limits diagram				Maximal operating pressure - Ethylenglykol [bar]	6	
EVI - vapour injection with economizer			for more see operating limits diagram	Volume flow - Ethylenglykol [m3/h]						3.44	Internal pressure drop - Ethylenglykol [kPa]
Electrical connection data						for more see operating limits diagram	Temperature difference - Ethylenglykol	3 K			ECM speed circulator - evaporator
Line voltage [#~ V/Hz]	3~ 400/50				for more see operating limits diagram				UPM3 25-75		3 K
Current	nominal [A]	5.58	for more see operating limits diagram	UPM3 25-75						3 K	
	maximal [A]	10.90				for more see operating limits diagram	UPM3 25-75	3 K			
	starting [A]	15.06			for more see operating limits diagram				UPM3 25-75		3 K
Softstart	MCI 12		for more see operating limits diagram	UPM3 25-75						3 K	
Main safety	C25					for more see operating limits diagram	UPM3 25-75	3 K			
Control System					for more see operating limits diagram				UPM3 25-75		3 K
Main controller	SIEMENS	RVS 21 AVS 55.199	for more see operating limits diagram	UPM3 25-75						3 K	
Extension module	AVS75.391	AVS75.391 AVS75.3xx				for more see operating limits diagram	UPM3 25-75	3 K			
Bus Clip-In		LPB OCI346 Modbus OCI352			for more see operating limits diagram				UPM3 25-75		3 K
Online connection		Web server OZW672 ToSyMo	for more see operating limits diagram	UPM3 25-75						3 K	
*** with accessory						for more see operating limits diagram	UPM3 25-75	3 K			

WAMAK BW 14 EVI

ErP (EU) No 811/2013: Technical parameters for heat pump space heaters

Model	BW 14 EVI
Air-to-water heat pump	no
Brine-to-water heat pump	yes
Water-to-water heat pump	no
Low-temperature heat pump	no
Equipped with a supplementary heater	no
Heat pump combination heater	no
Temperature application	low (35°C - 30°C)
Climate conditions	average

Item	Symbol	Value	Unit	Item	Symbol	Value	Unit
Rated heat output at Tdesignh	Prated	14.5	kW	Seasonal space heating energy efficiency	η_s	211.4	%
Declared capacity for heating for part load at indoor temperature 20 °C and outdoor temperature Tj				Declared coefficient of performance or primary energy ratio for part load at indoor temperature 20 °C and outdoor temperature Tj			
Tj = -7 °C	Pdh	14.4	kW	Tj = -7 °C	COPd	4.74	-
Tj = +2 °C	Pdh	14.4	kW	Tj = +2 °C	COPd	5.2	-
Tj = +7 °C	Pdh	14.3	kW	Tj = +7 °C	COPd	5.6	-
Tj = +12 °C	Pdh	14.3	kW	Tj = +12 °C	COPd	6.1	-
Tj = bivalent temperature	Pdh	14.5	kW	Tj = bivalent temperature	COPd	4.6	-
Tj = operation limit temperature	Pdh	---	kW	Tj = operation limit temperature	COPd	---	-
Bivalent temperature	Tbiv	-10	°C	Tj = operation limit temperature	TOL	---	°C
Power consumption in modes other than active mode				Heating water operating limit temperature	WTOL	65	°C
Off mode	Poff	0.010	kW	Supplementary heater			
Thermostat-off mode	Pto	0.010	kW	Rated heat output	Psup	2.8	kW
Standby mode	Psb	0.010	kW	Type of energy input	electricity		
Crankcase heater mode	Pck	0.000	kW	For air-to-water heat pumps:			
Other items				Rated air flow rate, outdoors	-	---	m ³ /h
Capacity control	fixed			For water- or brine-to-water heat pumps: Rated brine or water flow rate, outdoor heat exchanger			
Sound power level							
indoors	Lwa	45	dB				
outdoors	Lwa	---	dB				
Annual energy consumption	Q _{HE}	5627.5	kWh				

Contact details: WAMAK, s.r.o., Orovnicna 252, 96652, Orovnicna, Slovakia, info@wamak.sk

WAMAK BW 14 EVI

ErP (EU) No 811/2013: Technical parameters for heat pump space heaters

Model	BW 14 EVI
Air-to-water heat pump	no
Brine-to-water heat pump	yes
Water-to-water heat pump	no
Low-temperature heat pump	no
Equipped with a supplementary heater	no
Heat pump combination heater	no
Temperature application	middle (55°C - 47°C)
Climate conditions	average

Item	Symbol	Value	Unit	Item	Symbol	Value	Unit
Rated heat output at Tdesignh	Prated	14.9	kW	Seasonal space heating energy efficiency	η_s	164.4	%
Declared capacity for heating for part load at indoor temperature 20 °C and outdoor temperature Tj				Declared coefficient of performance or primary energy ratio for part load at indoor temperature 20 °C and outdoor temperature Tj			
Tj = -7 °C	Pdh	14.9	kW	Tj = -7 °C	COPd	3.29	-
Tj = +2 °C	Pdh	14.9	kW	Tj = +2 °C	COPd	4.3	-
Tj = +7 °C	Pdh	14.6	kW	Tj = +7 °C	COPd	4.8	-
Tj = +12 °C	Pdh	14.6	kW	Tj = +12 °C	COPd	5.3	-
Tj = bivalent temperature	Pdh	14.9	kW	Tj = bivalent temperature	COPd	2.9	-
Tj = operation limit temperature	Pdh	---	kW	Tj = operation limit temperature	COPd	---	-
Bivalent temperature	Tbiv	-10	°C	Tj = operation limit temperature	TOL	---	°C
Power consumption in modes other than active mode				Heating water operating limit temperature	WTOL	65	°C
Off mode	Poff	0.010	kW	Supplementary heater			
Thermostat-off mode	Pto	0.010	kW	Rated heat output	Psup	2.8	kW
Standby mode	Psb	0.010	kW	Type of energy input	electricity		
Crankcase heater mode	Pck	0.000	kW				
Other items				For air-to-water heat pumps: Rated air flow rate, outdoors	-	---	m ³ /h
Capacity control	fixed			For water- or brine-to-water heat pumps: Rated brine or water flow rate, outdoor heat exchanger	-	3.44	m ³ /h
Sound power level							
indoors	Lwa	45	dB				
outdoors	Lwa	---	dB				
Annual energy consumption	Q _{HE}	7448.8	kWh				

Contact details: WAMAK, s.r.o., Orovnic 252, 96652, Orovnic, Slovakia, info@wamak.sk



ENERG Y IIA
 енергия - ενεργεια IE IA

WAMAK

BW 14 EVI



55 °C

35 °C



A+++

A+++



45 dB



--- dB

■ 16
 ■ 15
 ■ 15
 kW

■ 15
 ■ 15
 ■ 14
 kW



2019

811/2013

BW 14 EVI

ErP Data

	55 °C	35 °C
Energy class	A+++	A+++
η [%]	164.4	211.4
P_{rated} [kW]	15	15
Q_{HE} [kWh/y]	7449	5628
SCOP [-]	4.11	5.29
$T_{bivalent}$ [°C]	-10	-10

CONTROLLER



+ QAA55/75
 - QAA55/75

class VII
 class III

3.5% ↓
 1.5% ↓

Heating performance data

Version: v2024.010-BW-WW

Source - Brine [0°C] / Low Temperature [35°C]

ZHI14K1P-TFM_R410A_1_BWW

Operating conditions		Qh	P	COP
1	B0 / W30-35	14.5	3.1	4.63
2	B0 / W30-35 (MIN)	14.5	3.1	4.63
A	B0 / Wxx-34	14.4	3.0	4.74
B	B0 / Wxx-30	14.4	2.7	5.24
C	B0 / Wxx-27	14.3	2.5	5.65
D	B0 / Wxx-24	14.3	2.3	6.09
E	B0 / Wxx-35	14.5	3.1	4.63
F	B0 / Wxx-35	14.5	3.1	4.63

SCOP DATA EN 14825:2018	
Source - Brine [0°C] / Low Temperature [35°C]	
SCOPon	5.32
SCOPnet	5.32
SCOP	5.29
η [%]	211.45
Label	A+++
Qh [kWh]	5627
Pdesignh [kW]	14.5
Tbivalent [°C]	-10

Source - Brine [0°C] / Medium Temperature [55°C]

Operating conditions		Qh	P	COP
1	B0 / W47-55	14.9	5.2	2.88
2	B0 / W47-55 (MIN)	14.9	5.0	2.88
A	B0 / Wxx-52	14.9	4.7	3.29
B	B0 / Wxx-42	14.9	3.5	4.25
C	B0 / Wxx-36	14.6	3.1	4.75
D	B0 / Wxx-30	14.6	2.7	5.31
E	B0 / Wxx-55	14.9	5.2	2.88
F	B0 / Wxx-54	14.9	4.8	3.12

SCOP DATA EN 14825:2018	
Source - Brine [0°C] / Medium Temperature [55°C]	
SCOPon	4.13
SCOPnet	4.13
SCOP	4.11
η [%]	164.43
Label	A+++
Qh [kWh]	7449
Pdesignh [kW]	14.9
Tbivalent [°C]	-10

Source - Water [10°C] / Low Temperature [35°C]

Operating conditions		Qh	P	COP
1	W10 / W30-35	18.4	3.0	6.08
2	W10 / W30-35 (MIN)	18.4	3.0	6.08
A	W10 / Wxx-34	18.4	2.9	6.25
B	W10 / Wxx-30	18.5	2.6	6.99
C	W10 / Wxx-27	18.5	2.4	7.60
D	W10 / Wxx-24	18.5	2.2	8.26
E	W10 / Wxx-35	18.4	3.0	6.08
F	W10 / Wxx-35	18.4	3.0	6.08

SCOP DATA EN 14825:2018	
Source - Water [10°C] / Low Temperature [35°C]	
SCOPon	7.11
SCOPnet	7.11
SCOP	7.06
η [%]	282.51
Label	A+++
Qh [kWh]	5343
Pdesignh [kW]	18.4
Tbivalent [°C]	-10.00

Source - Water [10°C] / Medium Temperature [55°C]

	Operating conditions	Qh	P	COP
1	W10 / W47-55	18.3	5.1	3.55
2	W10 / W47-55 (MIN)	18.3	5.1	3.55
A	W10 / Wxx-52	18.5	4.6	3.99
B	W10 / Wxx-42	18.6	3.5	5.37
C	W10 / Wxx-36	18.6	3.0	6.26
D	W10 / Wxx-30	18.7	2.6	7.09
E	W10 / Wxx-55	18.3	5.1	3.55
F	W10 / Wxx-55	18.3	5.1	3.55

SCOP DATA EN 14825:2018	
Source - Water [10°C] / Medium Temperature [55°C]	
SCOPon	5.20
SCOPnet	5.20
SCOP	5.18
η [%]	207.03
Label	A+++
Qh [kWh]	7265
Pdesignh [kW]	18.3
Tbivalent [°C]	-10.00

Low temperature cooling W 12 / 7°C

	Operating conditions	Qc	P	EER
A	W30-35 / W12-7	11.4	3.4	3.37
B	W26-xx / W12-7	11.6	3.0	3.81
C	W22-xx / W12-7	11.8	2.7	4.30
D	W18-xx / W12-7	11.9	2.6	4.57

SEER DATA EN 14825:2018 [W 12 / 7°C]	
SEERon	4.15
SEER	4.13
Qc [kWh]	6600
η [%]	165.35

Radiant cooling W 23 / 18°C

	Operating conditions	Qc	P	EER
A	W50-xx / W23-18	13.1	5.6	2.36
B	W40-xx / W23-18	14.3	4.3	3.29
C	W30-35 / W23-18	15.3	3.4	4.54
D	W26-xx / W23-18	15.7	3.0	5.14

SEER DATA EN 14825:2018 [W 23 / 18°C]	
SEERon	5.61
SEER	5.58
Qc [kWh]	6600
η [%]	223.30

Performance lines - heating

— Qh-nom-35
 - - - Qh-min-35
 - - - Qh-max-65
 — Qh-nom-45
 — Qh-nom-55
— Qh-nom-65

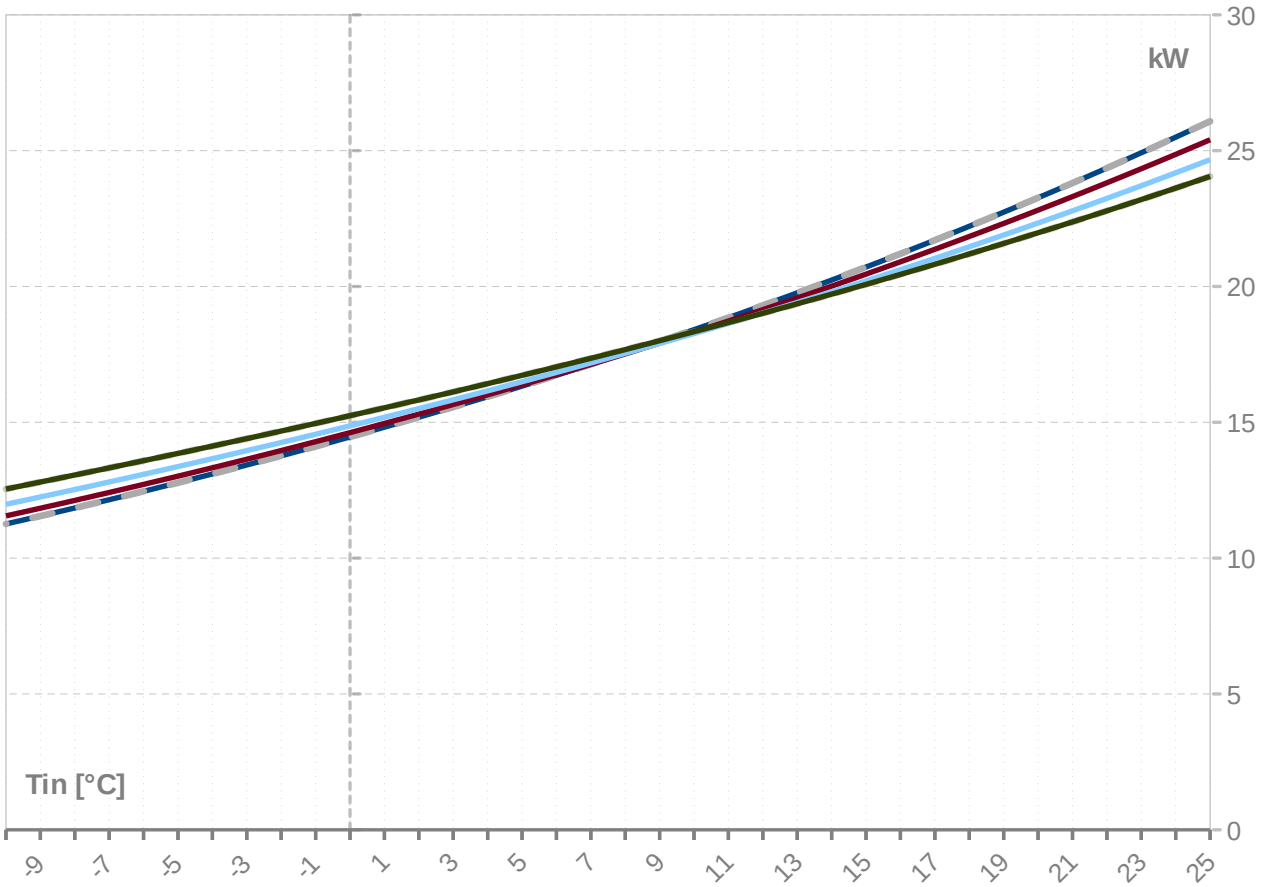

Performance lines - cooling

— Qc-nom-12-7
 — Qc-nom-23-18

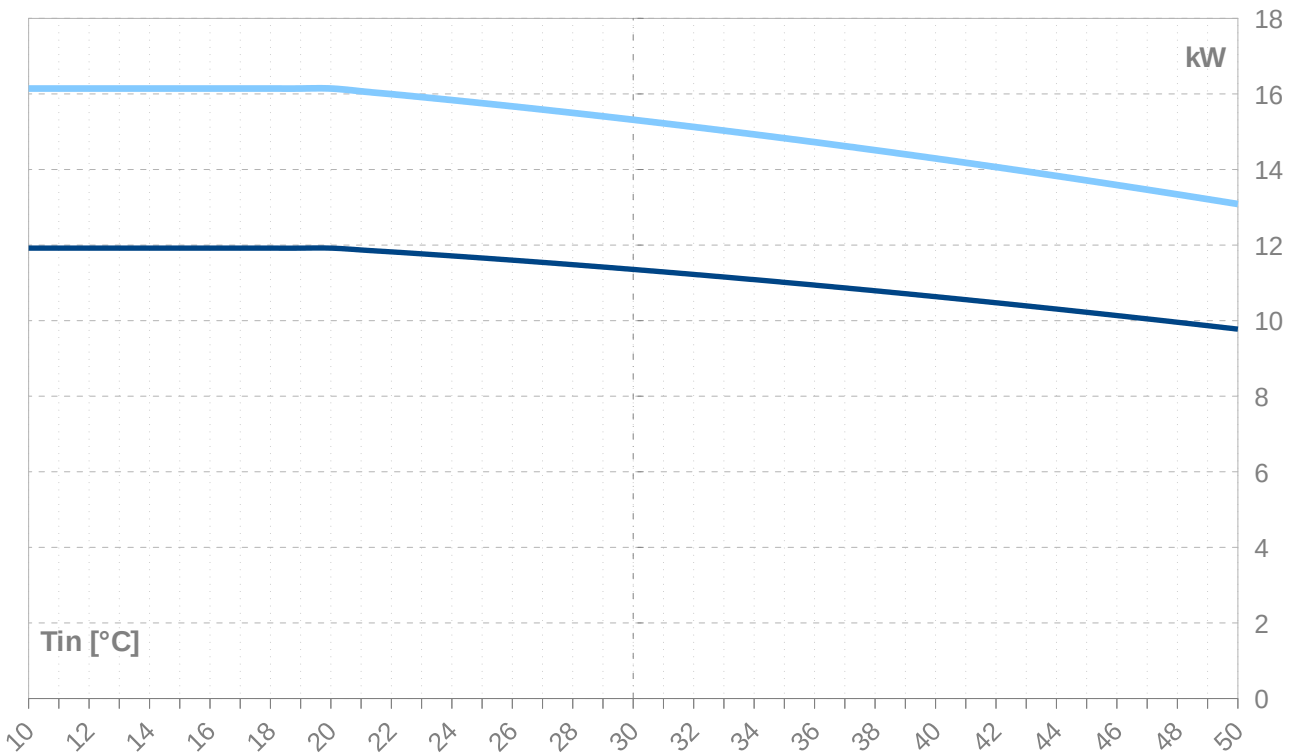

Th -OU		35										
Ts -IN	Qh nom	Qh min	Qh max	Pin nom	Pin min	Pin max	COP nom	Qc nom	Qc min	Qc max	I nom	
[°C]	[kW]	[kW]	[kW]	[kW]	[kW]	[kW]	kW / kW	[kW]	[kW]	[kW]	[A]	
25	26.1	26.1	26.1	2.8	2.8	2.8	9.28	23.5	23.5	23.5	5.3	
24	25.5	25.5	25.5	2.8	2.8	2.8	9.02	22.9	22.9	22.9	5.3	
23	24.9	24.9	24.9	2.8	2.8	2.8	8.77	22.3	22.3	22.3	5.3	
22	24.4	24.4	24.4	2.9	2.9	2.9	8.53	21.7	21.7	21.7	5.3	
21	23.8	23.8	23.8	2.9	2.9	2.9	8.29	21.1	21.1	21.1	5.4	
20	23.3	23.3	23.3	2.9	2.9	2.9	8.06	20.6	20.6	20.6	5.4	
19	22.7	22.7	22.7	2.9	2.9	2.9	7.84	20.0	20.0	20.0	5.4	
18	22.2	22.2	22.2	2.9	2.9	2.9	7.62	19.5	19.5	19.5	5.4	
17	21.7	21.7	21.7	2.9	2.9	2.9	7.41	19.0	19.0	19.0	5.4	
16	21.2	21.2	21.2	2.9	2.9	2.9	7.20	18.5	18.5	18.5	5.4	
15	20.7	20.7	20.7	3.0	3.0	3.0	7.00	18.0	18.0	18.0	5.5	
14	20.2	20.2	20.2	3.0	3.0	3.0	6.81	17.5	17.5	17.5	5.5	
13	19.8	19.8	19.8	3.0	3.0	3.0	6.62	17.0	17.0	17.0	5.5	
12	19.3	19.3	19.3	3.0	3.0	3.0	6.43	16.5	16.5	16.5	5.5	
11	18.9	18.9	18.9	3.0	3.0	3.0	6.26	16.0	16.0	16.0	5.5	
10	18.4	18.4	18.4	3.0	3.0	3.0	6.08	15.6	15.6	15.6	5.5	
9	18.0	18.0	18.0	3.0	3.0	3.0	5.92	15.1	15.1	15.1	5.6	
8	17.6	17.6	17.6	3.1	3.1	3.1	5.75	14.7	14.7	14.7	5.6	
7	17.1	17.1	17.1	3.1	3.1	3.1	5.60	14.3	14.3	14.3	5.6	
6	16.7	16.7	16.7	3.1	3.1	3.1	5.44	13.9	13.9	13.9	5.6	
5	16.3	16.3	16.3	3.1	3.1	3.1	5.30	13.5	13.5	13.5	5.6	
4	15.9	15.9	15.9	3.1	3.1	3.1	5.15	13.1	13.1	13.1	5.6	
3	15.6	15.6	15.6	3.1	3.1	3.1	5.02	12.7	12.7	12.7	5.6	
2	15.2	15.2	15.2	3.1	3.1	3.1	4.88	12.3	12.3	12.3	5.6	
1	14.8	14.8	14.8	3.1	3.1	3.1	4.75	11.9	11.9	11.9	5.7	
0	14.5	14.5	14.5	3.1	3.1	3.1	4.63	11.5	11.5	11.5	5.7	
-1	14.1	14.1	14.1	3.1	3.1	3.1	4.51	11.2	11.2	11.2	5.7	
-2	13.8	13.8	13.8	3.1	3.1	3.1	4.39	10.8	10.8	10.8	5.7	
-3	13.4	13.4	13.4	3.1	3.1	3.1	4.27	10.5	10.5	10.5	5.7	
-4	13.1	13.1	13.1	3.1	3.1	3.1	4.16	10.2	10.2	10.2	5.7	
-5	12.8	12.8	12.8	3.1	3.1	3.1	4.06	9.8	9.8	9.8	5.7	
-6	12.5	12.5	12.5	3.1	3.1	3.1	3.96	9.5	9.5	9.5	5.7	
-7	12.1	12.1	12.1	3.1	3.1	3.1	3.86	9.2	9.2	9.2	5.7	
-8	11.8	11.8	11.8	3.1	3.1	3.1	3.76	8.9	8.9	8.9	5.7	
-9	11.5	11.5	11.5	3.1	3.1	3.1	3.67	8.6	8.6	8.6	5.7	
-10	11.3	11.3	11.3	3.1	3.1	3.1	3.58	8.3	8.3	8.3	5.7	
-11	11.0	11.0	11.0	3.1	3.1	3.1	3.49	8.0	8.0	8.0	5.7	
-12	10.7	10.7	10.7	3.1	3.1	3.1	3.41	7.8	7.8	7.8	5.7	
-13	10.4	10.4	10.4	3.1	3.1	3.1	3.33	7.5	7.5	7.5	5.7	
-14	10.2	10.2	10.2	3.1	3.1	3.1	3.25	7.2	7.2	7.2	5.7	
-15	9.9	9.9	9.9	3.1	3.1	3.1	3.18	7.0	7.0	7.0	5.7	

-- attention: operating limits not reflected in performance table

ZHI14K1P-TFM_R410A_1_BWW

Th -OU	45										
[°C]	Qh nom [kW]	Qh min [kW]	Qh max [kW]	Pin nom [kW]	Pin min [kW]	Pin max [kW]	COP nom kW / kW	Qc nom [kW]	Qc min [kW]	Qc max [kW]	I nom [A]
25	25.4	25.4	25.4	3.7	3.7	3.7	6.91	22.0	22.0	22.0	6.3
24	24.9	24.9	24.9	3.7	3.7	3.7	6.73	21.4	21.4	21.4	6.3
23	24.3	24.3	24.3	3.7	3.7	3.7	6.56	20.9	20.9	20.9	6.4
22	23.8	23.8	23.8	3.7	3.7	3.7	6.39	20.3	20.3	20.3	6.4
21	23.3	23.3	23.3	3.7	3.7	3.7	6.22	19.8	19.8	19.8	6.4
20	22.8	22.8	22.8	3.8	3.8	3.8	6.06	19.3	19.3	19.3	6.4
19	22.3	22.3	22.3	3.8	3.8	3.8	5.91	18.8	18.8	18.8	6.4
18	21.8	21.8	21.8	3.8	3.8	3.8	5.75	18.3	18.3	18.3	6.5
17	21.4	21.4	21.4	3.8	3.8	3.8	5.61	17.8	17.8	17.8	6.5
16	20.9	20.9	20.9	3.8	3.8	3.8	5.46	17.3	17.3	17.3	6.5
15	20.5	20.5	20.5	3.8	3.8	3.8	5.33	16.9	16.9	16.9	6.5
14	20.0	20.0	20.0	3.9	3.9	3.9	5.19	16.4	16.4	16.4	6.5
13	19.6	19.6	19.6	3.9	3.9	3.9	5.06	16.0	16.0	16.0	6.6
12	19.1	19.1	19.1	3.9	3.9	3.9	4.93	15.5	15.5	15.5	6.6
11	18.7	18.7	18.7	3.9	3.9	3.9	4.81	15.1	15.1	15.1	6.6
10	18.3	18.3	18.3	3.9	3.9	3.9	4.69	14.7	14.7	14.7	6.6
9	17.9	17.9	17.9	3.9	3.9	3.9	4.57	14.3	14.3	14.3	6.6
8	17.5	17.5	17.5	3.9	3.9	3.9	4.46	13.9	13.9	13.9	6.6
7	17.1	17.1	17.1	3.9	3.9	3.9	4.35	13.5	13.5	13.5	6.6
6	16.8	16.8	16.8	3.9	3.9	3.9	4.25	13.1	13.1	13.1	6.7
5	16.4	16.4	16.4	4.0	4.0	4.0	4.14	12.7	12.7	12.7	6.7
4	16.0	16.0	16.0	4.0	4.0	4.0	4.04	12.3	12.3	12.3	6.7
3	15.7	15.7	15.7	4.0	4.0	4.0	3.95	12.0	12.0	12.0	6.7
2	15.3	15.3	15.3	4.0	4.0	4.0	3.85	11.6	11.6	11.6	6.7
1	15.0	15.0	15.0	4.0	4.0	4.0	3.76	11.2	11.2	11.2	6.7
0	14.6	14.6	14.6	4.0	4.0	4.0	3.67	10.9	10.9	10.9	6.7
-1	14.3	14.3	14.3	4.0	4.0	4.0	3.59	10.6	10.6	10.6	6.7
-2	14.0	14.0	14.0	4.0	4.0	4.0	3.51	10.2	10.2	10.2	6.7
-3	13.6	13.6	13.6	4.0	4.0	4.0	3.43	9.9	9.9	9.9	6.7
-4	13.3	13.3	13.3	4.0	4.0	4.0	3.35	9.6	9.6	9.6	6.7
-5	13.0	13.0	13.0	4.0	4.0	4.0	3.27	9.3	9.3	9.3	6.7
-6	12.7	12.7	12.7	4.0	4.0	4.0	3.20	9.0	9.0	9.0	6.7
-7	12.4	12.4	12.4	4.0	4.0	4.0	3.13	8.7	8.7	8.7	6.7
-8	12.1	12.1	12.1	4.0	4.0	4.0	3.06	8.4	8.4	8.4	6.7
-9	11.8	11.8	11.8	4.0	4.0	4.0	2.99	8.1	8.1	8.1	6.7
-10	11.6	11.6	11.6	3.9	3.9	3.9	2.93	7.9	7.9	7.9	6.7
-11	11.3	11.3	11.3	3.9	3.9	3.9	2.87	7.6	7.6	7.6	6.6
-12	11.0	11.0	11.0	3.9	3.9	3.9	2.81	7.3	7.3	7.3	6.6
-13	10.7	10.7	10.7	3.9	3.9	3.9	2.75	7.1	7.1	7.1	6.6
-14	10.5	10.5	10.5	3.9	3.9	3.9	2.69	6.8	6.8	6.8	6.6
-15	10.2	10.2	10.2	3.9	3.9	3.9	2.64	6.6	6.6	6.6	6.6

-- attention: operating limits not reflected in performance table

Th -OU		55										
	[°C]											
Ts -IN	Qh nom	Qh min	Qh max	Pin nom	Pin min	Pin max	COP nom	Qc nom	Qc min	Qc max	I nom	
[°C]	[kW]	[kW]	[kW]	[kW]	[kW]	[kW]	kW / kW	[kW]	[kW]	[kW]	[A]	
25	24.7	24.7	24.7	4.9	4.9	4.9	5.00	20.1	20.1	20.1	7.9	
24	24.2	24.2	24.2	5.0	5.0	5.0	4.88	19.6	19.6	19.6	8.0	
23	23.7	23.7	23.7	5.0	5.0	5.0	4.77	19.1	19.1	19.1	8.0	
22	23.2	23.2	23.2	5.0	5.0	5.0	4.66	18.6	18.6	18.6	8.0	
21	22.8	22.8	22.8	5.0	5.0	5.0	4.55	18.1	18.1	18.1	8.0	
20	22.3	22.3	22.3	5.0	5.0	5.0	4.45	17.6	17.6	17.6	8.1	
19	21.9	21.9	21.9	5.0	5.0	5.0	4.35	17.2	17.2	17.2	8.1	
18	21.5	21.5	21.5	5.1	5.1	5.1	4.25	16.7	16.7	16.7	8.1	
17	21.0	21.0	21.0	5.1	5.1	5.1	4.15	16.3	16.3	16.3	8.1	
16	20.6	20.6	20.6	5.1	5.1	5.1	4.06	15.9	15.9	15.9	8.1	
15	20.2	20.2	20.2	5.1	5.1	5.1	3.97	15.5	15.5	15.5	8.2	
14	19.8	19.8	19.8	5.1	5.1	5.1	3.88	15.0	15.0	15.0	8.2	
13	19.4	19.4	19.4	5.1	5.1	5.1	3.79	14.6	14.6	14.6	8.2	
12	19.0	19.0	19.0	5.1	5.1	5.1	3.71	14.2	14.2	14.2	8.2	
11	18.6	18.6	18.6	5.1	5.1	5.1	3.63	13.8	13.8	13.8	8.2	
10	18.3	18.3	18.3	5.1	5.1	5.1	3.55	13.5	13.5	13.5	8.2	
9	17.9	17.9	17.9	5.2	5.2	5.2	3.48	13.1	13.1	13.1	8.2	
8	17.5	17.5	17.5	5.2	5.2	5.2	3.40	12.7	12.7	12.7	8.2	
7	17.2	17.2	17.2	5.2	5.2	5.2	3.33	12.4	12.4	12.4	8.3	
6	16.8	16.8	16.8	5.2	5.2	5.2	3.26	12.0	12.0	12.0	8.3	
5	16.5	16.5	16.5	5.2	5.2	5.2	3.19	11.7	11.7	11.7	8.3	
4	16.2	16.2	16.2	5.2	5.2	5.2	3.13	11.3	11.3	11.3	8.3	
3	15.8	15.8	15.8	5.2	5.2	5.2	3.06	11.0	11.0	11.0	8.3	
2	15.5	15.5	15.5	5.2	5.2	5.2	3.00	10.7	10.7	10.7	8.3	
1	15.2	15.2	15.2	5.2	5.2	5.2	2.94	10.4	10.4	10.4	8.3	
0	14.9	14.9	14.9	5.2	5.2	5.2	2.88	10.0	10.0	10.0	8.3	
-1	14.6	14.6	14.6	5.2	5.2	5.2	2.82	9.7	9.7	9.7	8.3	
-2	14.3	14.3	14.3	5.2	5.2	5.2	2.77	9.4	9.4	9.4	8.2	
-3	14.0	14.0	14.0	5.1	5.1	5.1	2.71	9.2	9.2	9.2	8.2	
-4	13.7	13.7	13.7	5.1	5.1	5.1	2.66	8.9	8.9	8.9	8.2	
-5	13.4	13.4	13.4	5.1	5.1	5.1	2.61	8.6	8.6	8.6	8.2	
-6	13.1	13.1	13.1	5.1	5.1	5.1	2.56	8.3	8.3	8.3	8.2	
-7	12.8	12.8	12.8	5.1	5.1	5.1	2.51	8.0	8.0	8.0	8.2	
-8	12.5	12.5	12.5	5.1	5.1	5.1	2.46	7.8	7.8	7.8	8.2	
-9	12.2	12.2	12.2	5.1	5.1	5.1	2.42	7.5	7.5	7.5	8.1	
-10	12.0	12.0	12.0	5.0	5.0	5.0	2.37	7.3	7.3	7.3	8.1	
-11	11.7	11.7	11.7	5.0	5.0	5.0	2.33	7.0	7.0	7.0	8.1	
-12	11.4	11.4	11.4	5.0	5.0	5.0	2.29	6.8	6.8	6.8	8.0	
-13	11.2	11.2	11.2	5.0	5.0	5.0	2.25	6.5	6.5	6.5	8.0	
-14	10.9	10.9	10.9	4.9	4.9	4.9	2.21	6.3	6.3	6.3	8.0	
-15	10.7	10.7	10.7	4.9	4.9	4.9	2.17	6.1	6.1	6.1	7.9	

-- attention: operating limits not reflected in performance table

Th -OU	65 (T-max)										
	Qh nom	Qh min	Qh max	Pin nom	Pin min	Pin max	COP nom	Qc nom	Qc min	Qc max	I nom
[°C]	[kW]	[kW]	[kW]	[kW]	[kW]	[kW]	kW / kW	[kW]	[kW]	[kW]	[A]
25	24.1	24.1	24.1	6.5	6.5	6.5	3.72	18.0	18.0	18.0	10.1
24	23.6	23.6	23.6	6.5	6.5	6.5	3.64	17.6	17.6	17.6	10.1
23	23.2	23.2	23.2	6.5	6.5	6.5	3.57	17.1	17.1	17.1	10.1
22	22.8	22.8	22.8	6.5	6.5	6.5	3.49	16.7	16.7	16.7	10.1
21	22.4	22.4	22.4	6.5	6.5	6.5	3.42	16.3	16.3	16.3	10.2
20	22.0	22.0	22.0	6.5	6.5	6.5	3.36	15.9	15.9	15.9	10.2
19	21.6	21.6	21.6	6.6	6.6	6.6	3.29	15.5	15.5	15.5	10.2
18	21.2	21.2	21.2	6.6	6.6	6.6	3.22	15.1	15.1	15.1	10.2
17	20.8	20.8	20.8	6.6	6.6	6.6	3.16	14.7	14.7	14.7	10.2
16	20.4	20.4	20.4	6.6	6.6	6.6	3.10	14.3	14.3	14.3	10.2
15	20.1	20.1	20.1	6.6	6.6	6.6	3.04	13.9	13.9	13.9	10.3
14	19.7	19.7	19.7	6.6	6.6	6.6	2.98	13.5	13.5	13.5	10.3
13	19.4	19.4	19.4	6.6	6.6	6.6	2.93	13.2	13.2	13.2	10.3
12	19.0	19.0	19.0	6.6	6.6	6.6	2.87	12.8	12.8	12.8	10.3
11	18.7	18.7	18.7	6.6	6.6	6.6	2.82	12.5	12.5	12.5	10.3
10	18.3	18.3	18.3	6.6	6.6	6.6	2.77	12.1	12.1	12.1	10.3
9	18.0	18.0	18.0	6.6	6.6	6.6	2.72	11.8	11.8	11.8	10.3
8	17.7	17.7	17.7	6.6	6.6	6.6	2.67	11.5	11.5	11.5	10.3
7	17.4	17.4	17.4	6.6	6.6	6.6	2.62	11.2	11.2	11.2	10.3
6	17.0	17.0	17.0	6.6	6.6	6.6	2.57	10.9	10.9	10.9	10.3
5	16.7	16.7	16.7	6.6	6.6	6.6	2.53	10.5	10.5	10.5	10.3
4	16.4	16.4	16.4	6.6	6.6	6.6	2.48	10.2	10.2	10.2	10.3
3	16.1	16.1	16.1	6.6	6.6	6.6	2.44	10.0	10.0	10.0	10.3
2	15.8	15.8	15.8	6.6	6.6	6.6	2.40	9.7	9.7	9.7	10.3
1	15.5	15.5	15.5	6.6	6.6	6.6	2.36	9.4	9.4	9.4	10.2
0	15.2	15.2	15.2	6.6	6.6	6.6	2.32	9.1	9.1	9.1	10.2
-1	15.0	15.0	15.0	6.6	6.6	6.6	2.28	8.8	8.8	8.8	10.2
-2	14.7	14.7	14.7	6.5	6.5	6.5	2.24	8.6	8.6	8.6	10.2
-3	14.4	14.4	14.4	6.5	6.5	6.5	2.20	8.3	8.3	8.3	10.2
-4	14.1	14.1	14.1	6.5	6.5	6.5	2.17	8.0	8.0	8.0	10.1
-5	13.9	13.9	13.9	6.5	6.5	6.5	2.13	7.8	7.8	7.8	10.1
-6	13.6	13.6	13.6	6.5	6.5	6.5	2.10	7.5	7.5	7.5	10.1
-7	13.3	13.3	13.3	6.4	6.4	6.4	2.07	7.3	7.3	7.3	10.0
-8	13.1	13.1	13.1	6.4	6.4	6.4	2.04	7.1	7.1	7.1	10.0
-9	12.8	12.8	12.8	6.4	6.4	6.4	2.00	6.8	6.8	6.8	10.0
-10	12.5	12.5	12.5	6.4	6.4	6.4	1.97	6.6	6.6	6.6	9.9
-11	12.3	12.3	12.3	6.3	6.3	6.3	1.94	6.4	6.4	6.4	9.9
-12	12.0	12.0	12.0	6.3	6.3	6.3	1.91	6.2	6.2	6.2	9.8
-13	11.8	11.8	11.8	6.3	6.3	6.3	1.89	5.9	5.9	5.9	9.8
-14	11.5	11.5	11.5	6.2	6.2	6.2	1.86	5.7	5.7	5.7	9.7
-15	11.3	11.3	11.3	6.2	6.2	6.2	1.83	5.5	5.5	5.5	9.7

-- attention: operating limits not reflected in performance table

Tc -OU		W 12 / 7 °C										
Ts -IN	Qc nom	Qc min	Qc max	Pin nom	Pin min	Pin max	EER	Qh nom	Qh min	Qh max	I nom	
[°C]	[kW]	[kW]	[kW]	[kW]	[kW]	[kW]	kW / kW	[kW]	[kW]	[kW]	[A]	
40	10.6	10.6	10.6	4.3	4.3	4.3	2.45	14.7	14.7	14.7	7.2	
39	10.7	10.7	10.7	4.2	4.2	4.2	2.53	14.7	14.7	14.7	7.0	
38	10.8	10.8	10.8	4.1	4.1	4.1	2.61	14.6	14.6	14.6	6.9	
37	10.9	10.9	10.9	4.0	4.0	4.0	2.70	14.6	14.6	14.6	6.8	
36	10.9	10.9	10.9	3.9	3.9	3.9	2.79	14.6	14.6	14.6	6.6	
35	11.0	11.0	11.0	3.8	3.8	3.8	2.88	14.6	14.6	14.6	6.5	
34	11.1	11.1	11.1	3.7	3.7	3.7	2.97	14.6	14.6	14.6	6.4	
33	11.2	11.2	11.2	3.6	3.6	3.6	3.06	14.6	14.6	14.6	6.3	
32	11.2	11.2	11.2	3.6	3.6	3.6	3.16	14.5	14.5	14.5	6.2	
31	11.3	11.3	11.3	3.5	3.5	3.5	3.26	14.5	14.5	14.5	6.1	
30	11.4	11.4	11.4	3.4	3.4	3.4	3.37	14.5	14.5	14.5	6.0	
29	11.4	11.4	11.4	3.3	3.3	3.3	3.47	14.5	14.5	14.5	5.9	
28	11.5	11.5	11.5	3.2	3.2	3.2	3.58	14.5	14.5	14.5	5.8	
27	11.5	11.5	11.5	3.1	3.1	3.1	3.69	14.5	14.5	14.5	5.7	
26	11.6	11.6	11.6	3.0	3.0	3.0	3.81	14.4	14.4	14.4	5.6	
25	11.7	11.7	11.7	3.0	3.0	3.0	3.93	14.4	14.4	14.4	5.5	
24	11.7	11.7	11.7	2.9	2.9	2.9	4.05	14.4	14.4	14.4	5.4	
23	11.8	11.8	11.8	2.8	2.8	2.8	4.17	14.4	14.4	14.4	5.3	
22	11.8	11.8	11.8	2.7	2.7	2.7	4.30	14.4	14.4	14.4	5.2	
21	11.9	11.9	11.9	2.7	2.7	2.7	4.44	14.4	14.4	14.4	5.1	
20	11.9	11.9	11.9	2.6	2.6	2.6	4.57	14.4	14.4	14.4	5.1	

Tc [°C]		W 23 / 18 °C										
0	Qc nom	Qc min	Qc max	Pin nom	Pin min	Pin max	EER	Qh nom	Qh min	Qh max	I nom	
[°C]	[kW]	[kW]	[kW]	[kW]	[kW]	[kW]	kW / kW	[kW]	[kW]	[kW]	[A]	
40	14.3	14.3	14.3	4.3	4.3	4.3	3.29	18.3	18.3	18.3	7.1	
39	14.4	14.4	14.4	4.2	4.2	4.2	3.40	18.3	18.3	18.3	6.9	
38	14.5	14.5	14.5	4.1	4.1	4.1	3.51	18.3	18.3	18.3	6.8	
37	14.6	14.6	14.6	4.0	4.0	4.0	3.63	18.3	18.3	18.3	6.7	
36	14.7	14.7	14.7	3.9	3.9	3.9	3.75	18.3	18.3	18.3	6.5	
35	14.8	14.8	14.8	3.8	3.8	3.8	3.87	18.3	18.3	18.3	6.4	
34	14.9	14.9	14.9	3.7	3.7	3.7	4.00	18.3	18.3	18.3	6.3	
33	15.0	15.0	15.0	3.6	3.6	3.6	4.13	18.3	18.3	18.3	6.2	
32	15.1	15.1	15.1	3.6	3.6	3.6	4.26	18.4	18.4	18.3	6.1	
31	15.2	15.2	15.2	3.5	3.5	3.5	4.40	18.4	18.4	18.3	5.9	
30	15.3	15.3	15.3	3.4	3.4	3.4	4.54	18.4	18.4	18.3	5.8	
29	15.4	15.4	15.4	3.3	3.3	3.3	4.68	18.4	18.4	18.3	5.7	
28	15.5	15.5	15.5	3.2	3.2	3.2	4.83	18.4	18.4	18.3	5.6	
27	15.6	15.6	15.6	3.1	3.1	3.1	4.99	18.4	18.4	18.3	5.5	
26	15.7	15.7	15.7	3.0	3.0	3.0	5.14	18.4	18.4	18.3	5.4	
25	15.8	15.8	15.8	3.0	3.0	3.0	5.31	18.4	18.4	18.3	5.4	
24	15.8	15.8	15.8	2.9	2.9	2.9	5.47	18.4	18.4	18.3	5.3	
23	15.9	15.9	15.9	2.8	2.8	2.8	5.65	18.5	18.5	18.3	5.2	
22	16.0	16.0	16.0	2.7	2.7	2.7	5.82	18.5	18.5	18.4	5.1	
21	16.1	16.1	16.1	2.7	2.7	2.7	6.00	18.5	18.5	18.4	5.0	
20	16.1	16.1	16.1	2.6	2.6	2.6	6.19	18.5	18.5	18.4	5.0	

-- attention: operating limits not reflected in performance table

LEGEND:

Ts-IN: Temperature renewable source - inlet [°C]
Th-OU: Temperature heating - outlet (flow) [°C]
Tc-OU: Temperature cooling - outlet (flow) [°C]
Qh nom: Heating capacity nominal
Qh min: Heating capacity minimal
Qh max: Heating capacity maximal
Pin nom: Power input at nominal heating capacity
Pin min: Power input at minimal heating capacity
Pin max: Power input at maximal heating capacity
COP nom: coefficient of performance at nominal heating capacity
Qc nom: cooling / heat extraction capacity at nominal heating capacity
Qc min: cooling / heat extraction at minimal heating capacity
Qc max: cooling / heat extraction at maximal heating capacity
I nom: Current at nominal heating capacity
EER: energy efficiency ratio at nominal cooling capacity

Operating limits

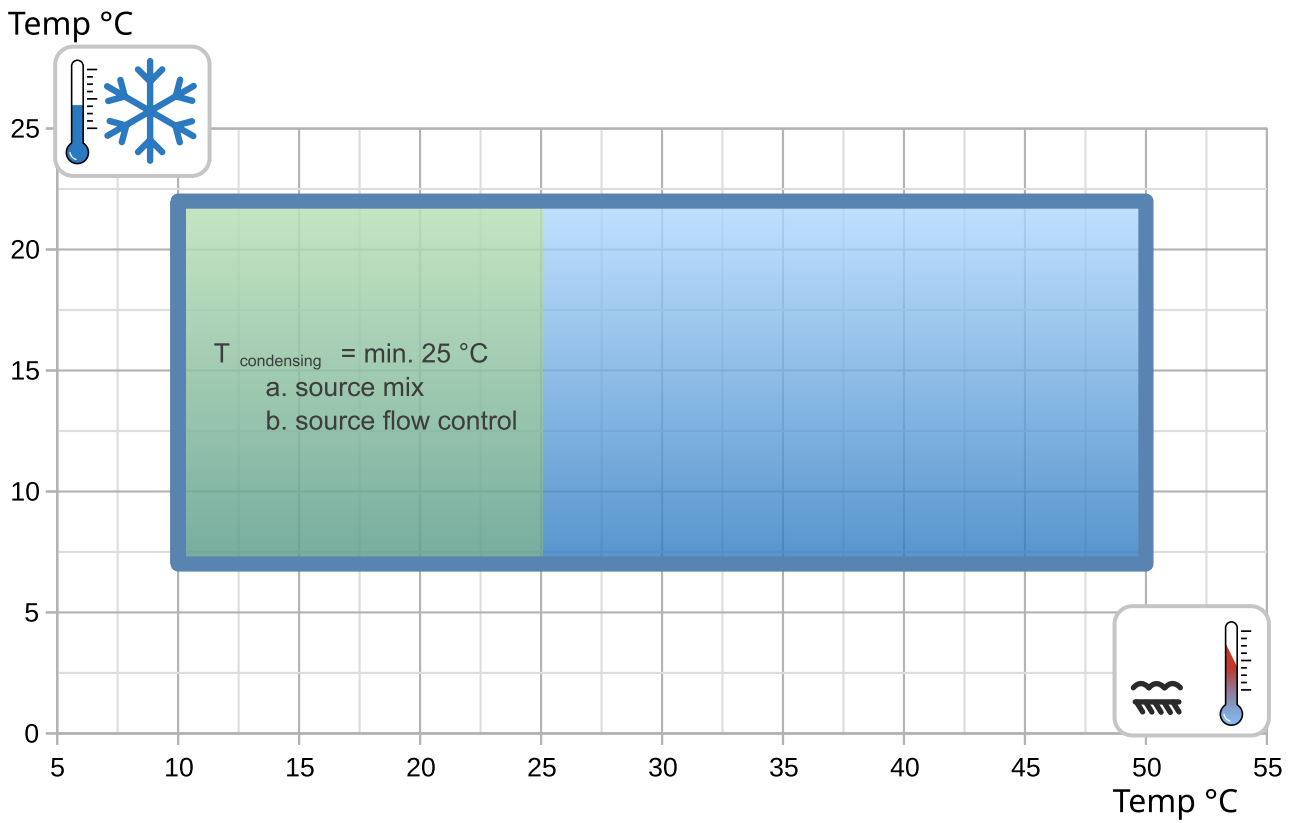
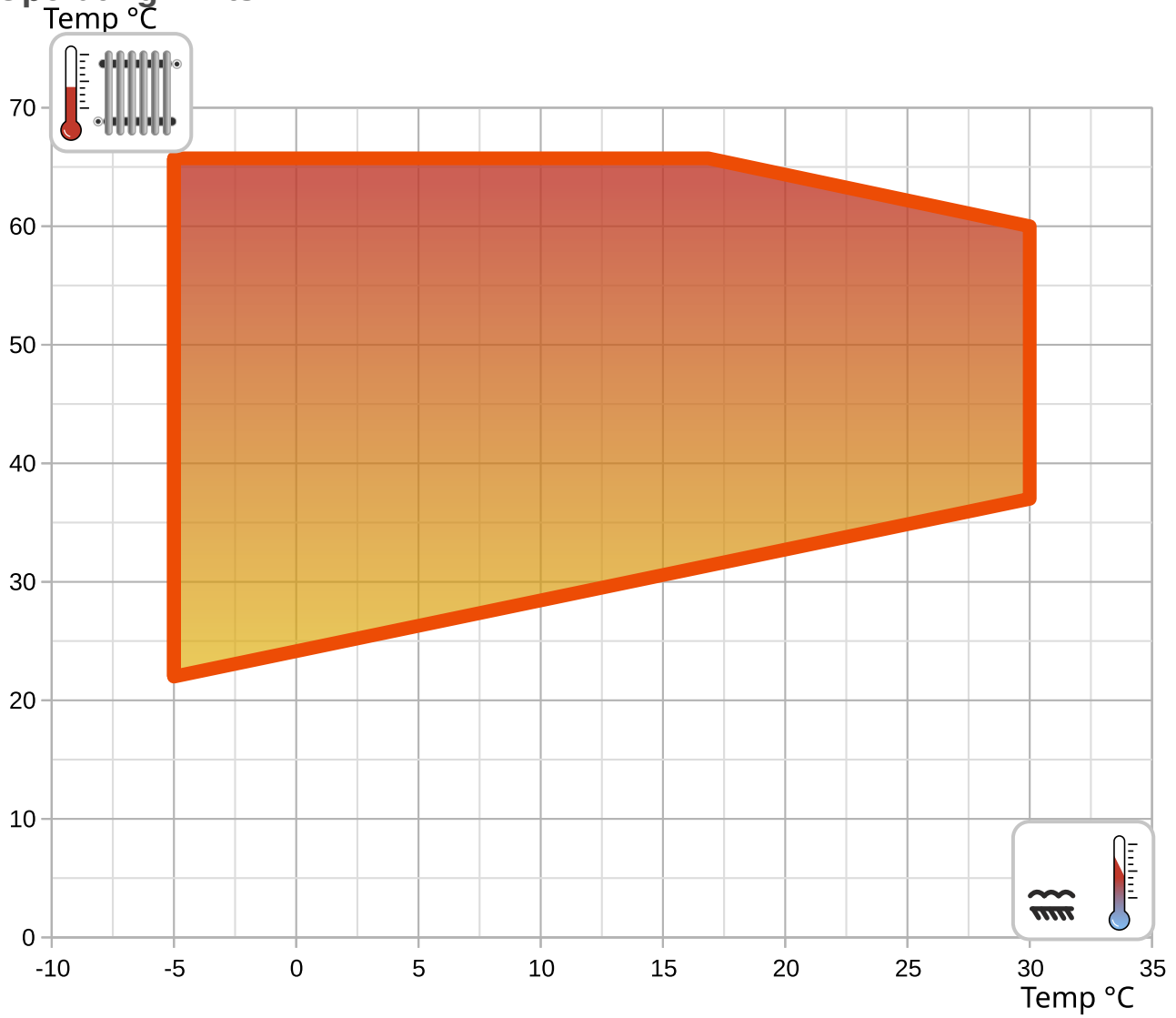

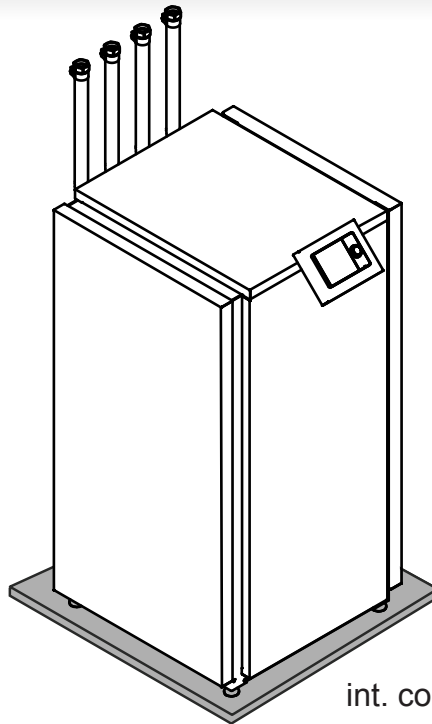
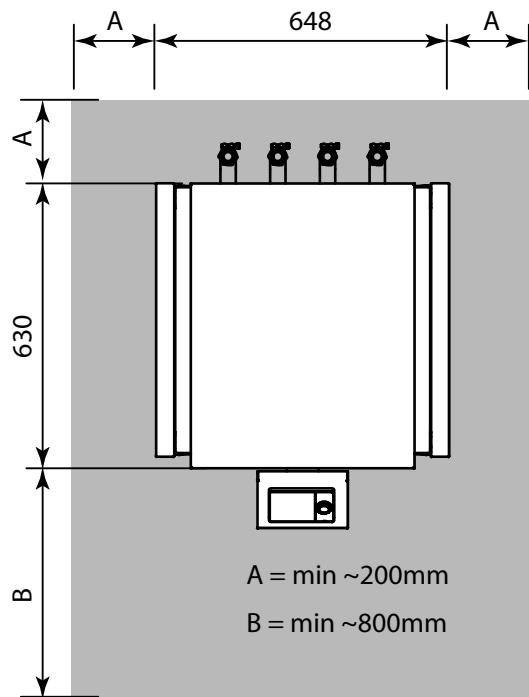
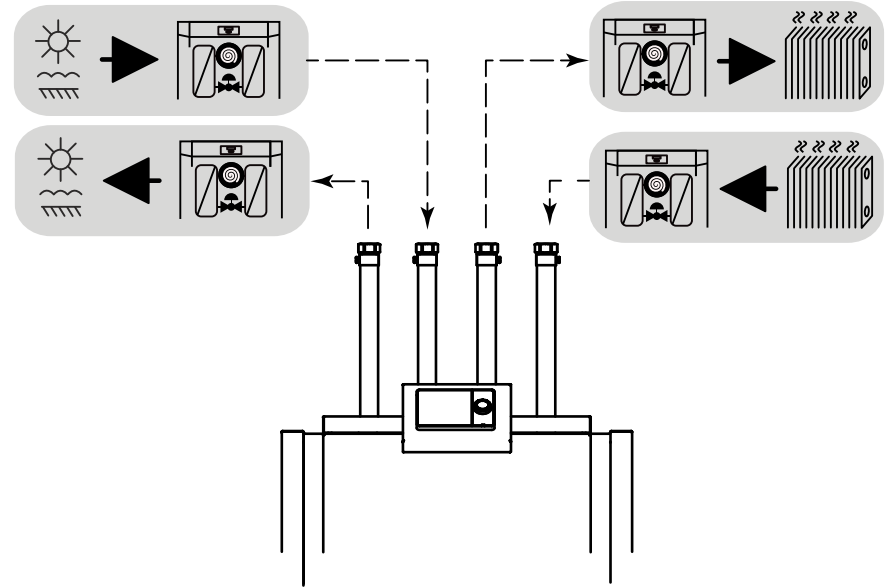
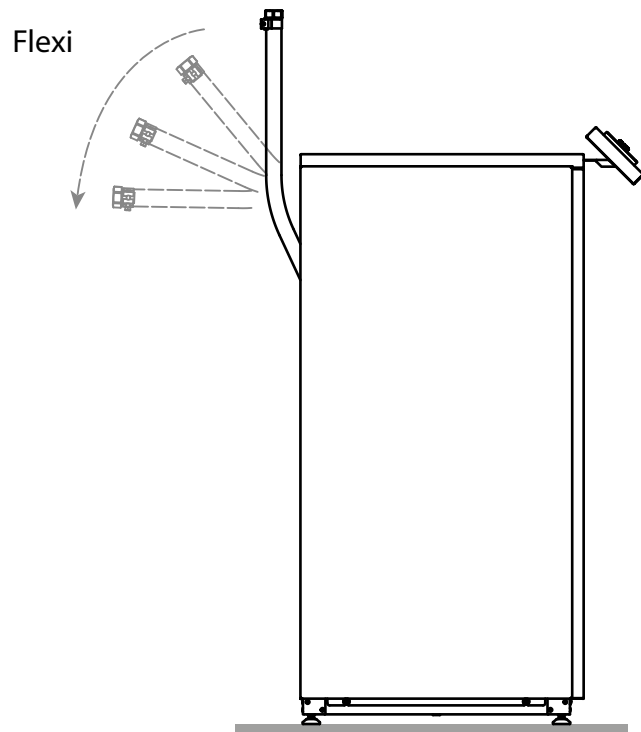
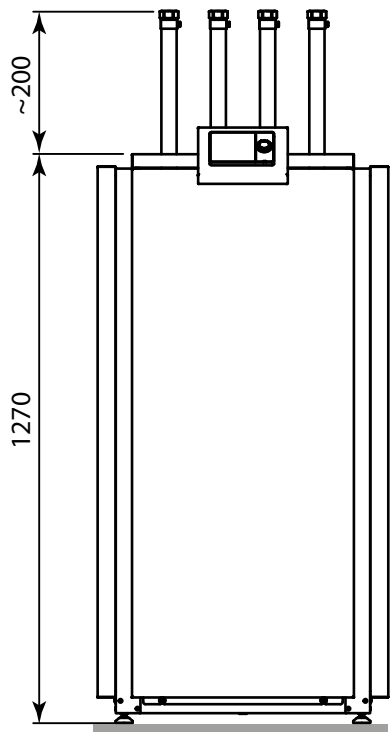

int. code: VN600

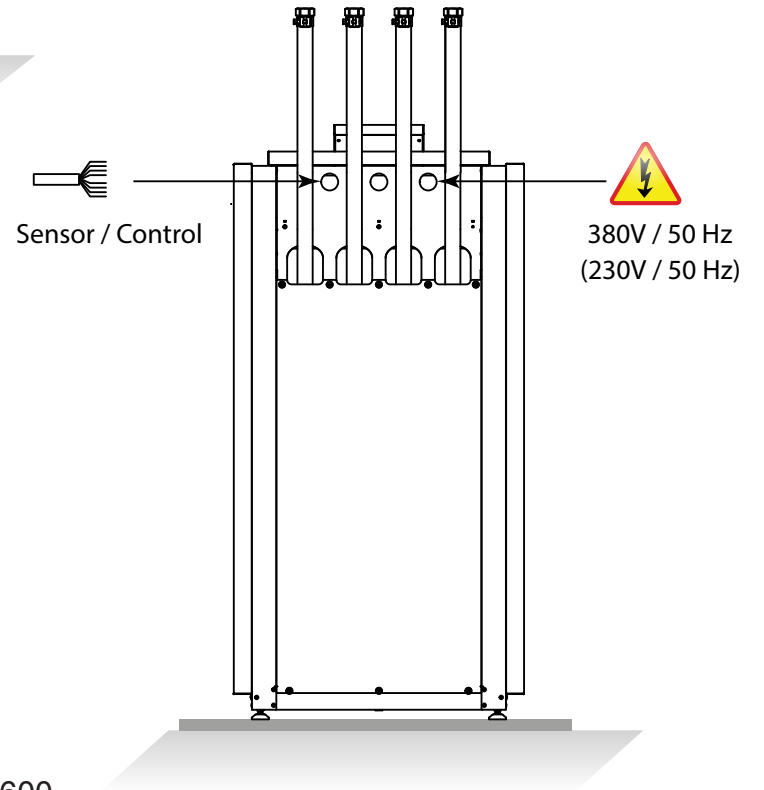

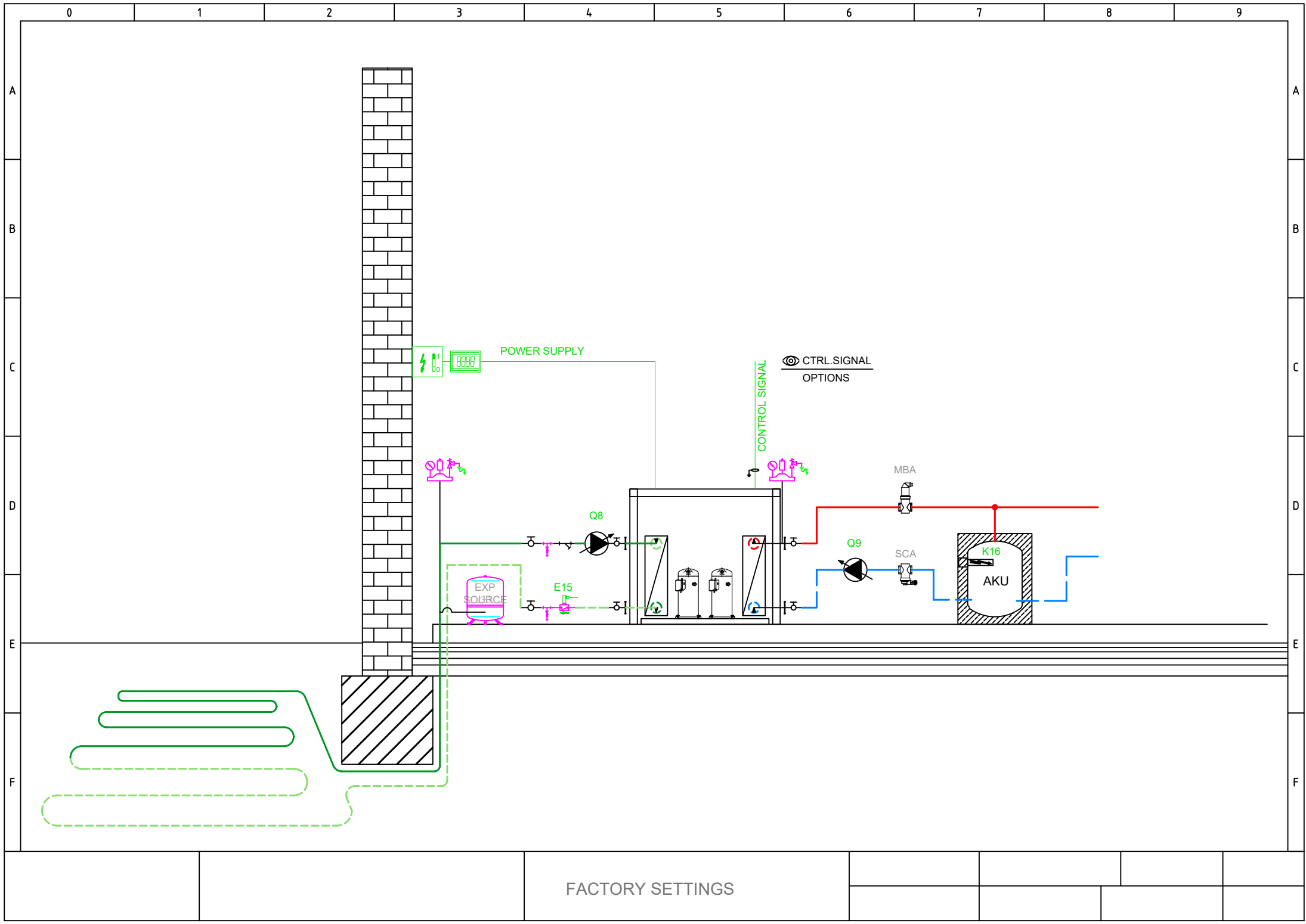

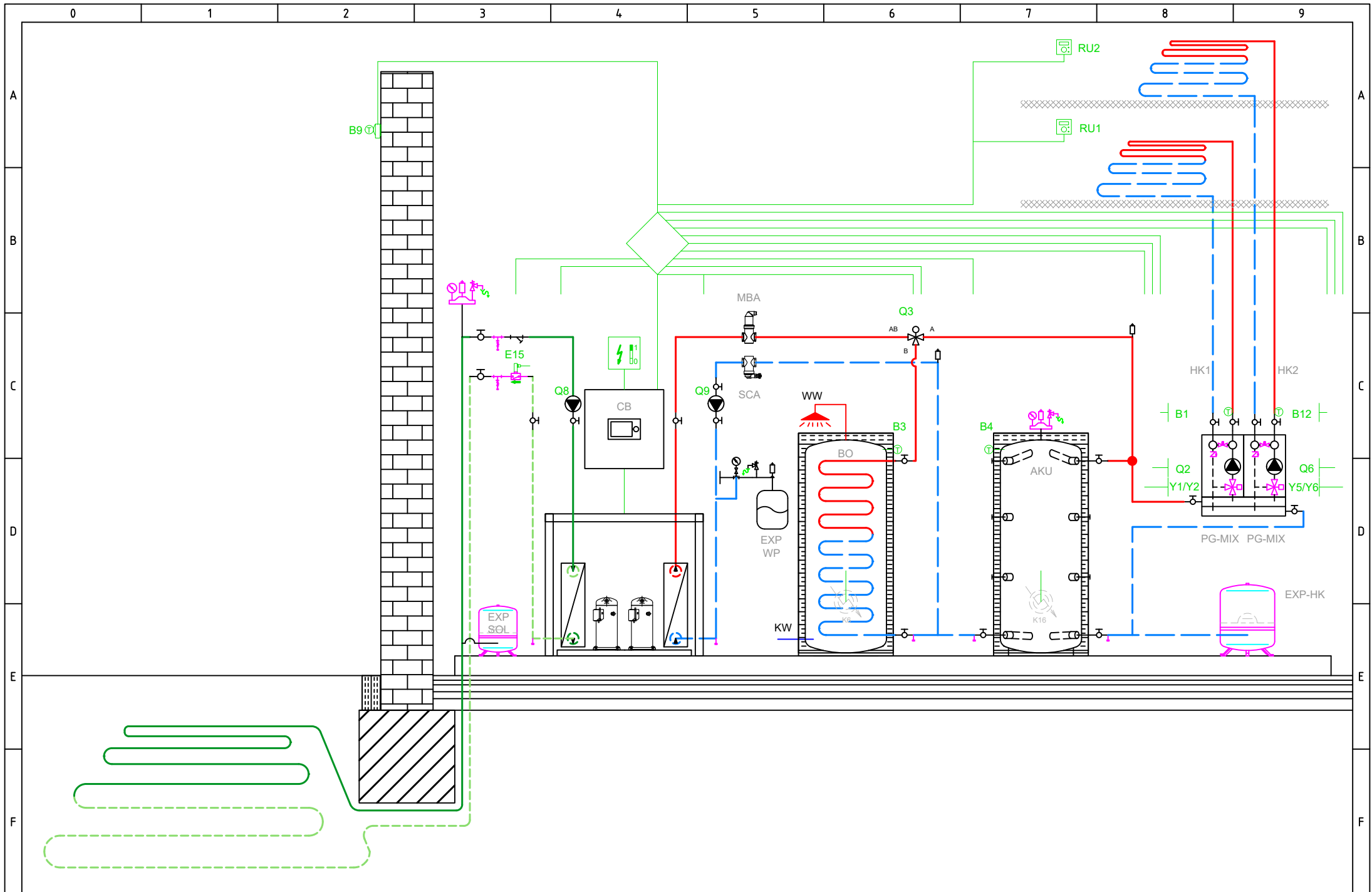

BASIC APPLICATION

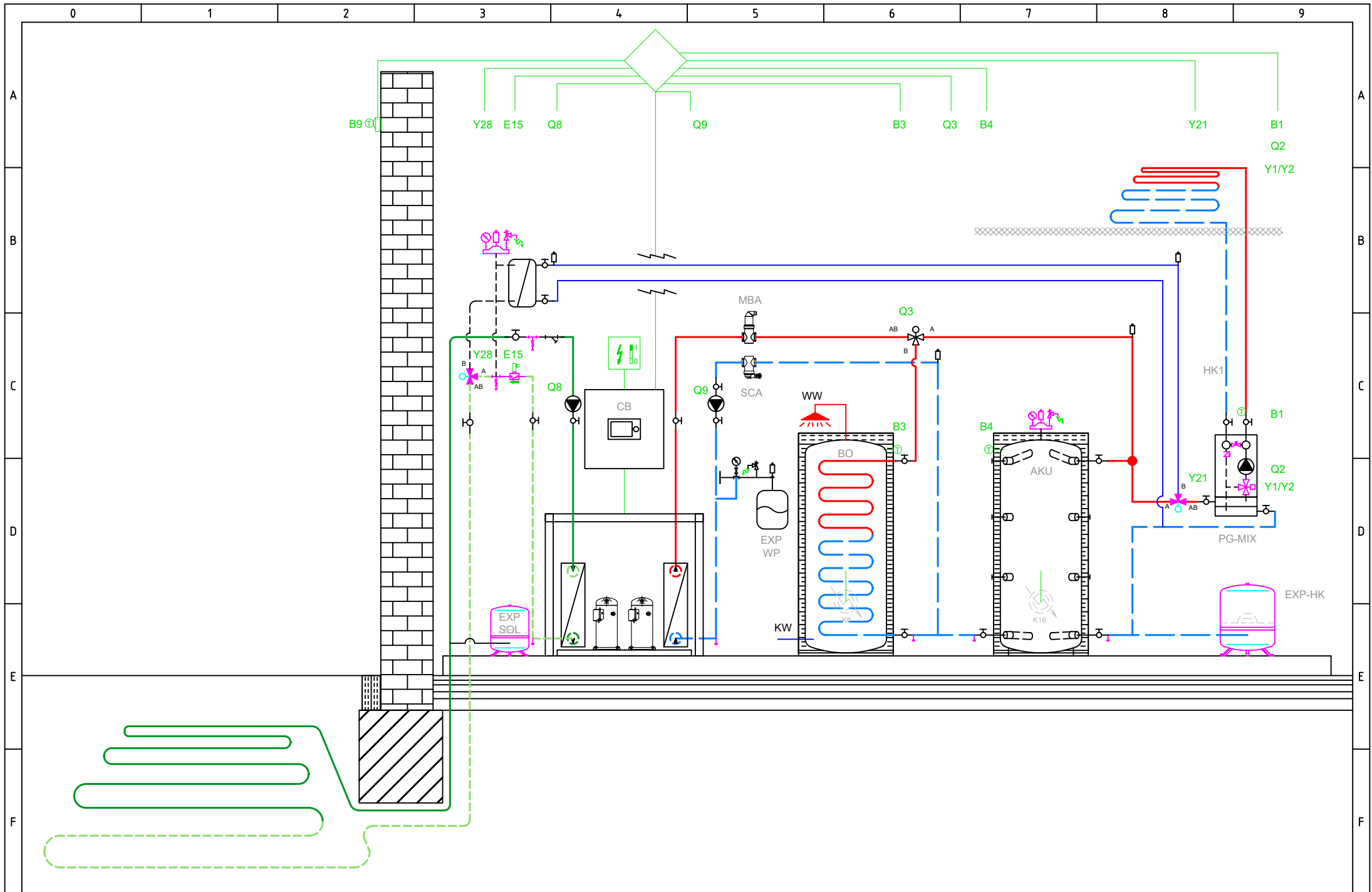

OPTIONAL APPLICATION

Total: max 6A
1 x QX...: max 2A

Main power supply 230V / 50 Hz
Ground
Neutral conductor

- E9 Low-pressure switch E9
- E10 High-pressure switch E10
- E15 Flow switch source E15
- E24 Flow switch consumers E24
- E6 Electrical utility lock E6
- E12 Overload compressor 2 E12
- E21 Mains supervision E21
- E22 Mains supervision E22
- E23 Mains supervision E23
- E11 Overload compressor 1 E11
- K1 Compressor stage 1 K1

Q8 Source pump Q8

Q9 Condenser pump Q9

K10 Alarm output K10

K40 Crankcase heater K40

K81 Valve evaporator K81

K82 Valve EVI K82

K2 Compressor stage 2 K2

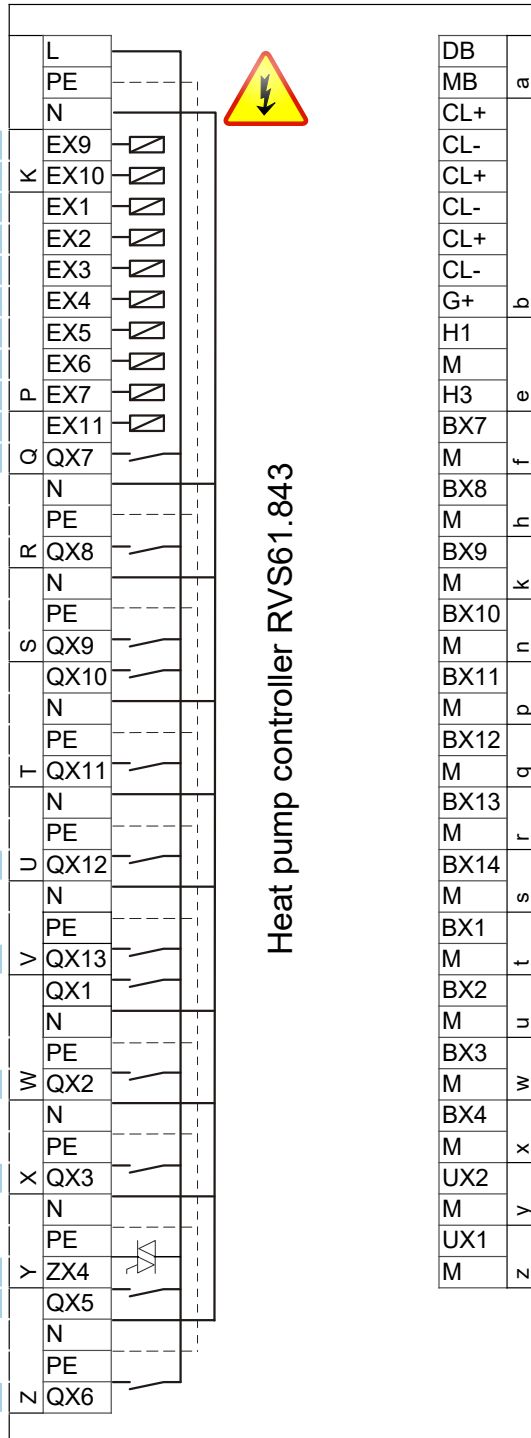

- DB LPB Bus data
- MB LPB Bus GND
- CL+ Room unit QAA...
- CL- Room unit QAA...
- CL+ Room unit QAA... 2.
- CL- Room unit QAA... 2.
- CL+ Room unit QAA... 3.
- CL- Room unit QAA... 3.
- G+ 12V supply → OUT
- H1
- M
- H3 Consumer request VK1
- BX7 B81 Hot-gas sensor K1 B81
- M
- BX8
- M
- BX9
- M
- BX10 B21 HP flow sensor B21
- M
- BX11
- M
- BX12 B71 HP return sensor B71
- M
- BX13 B91 Source inlet sensor B91
- M
- BX14 B84 Source outl sens B92/B84
- M
- BX1
- M
- BX2
- M
- BX3 B83 Refrig sensor liquid B83
- M
- BX4 B82 Hot-gas sensor K2 B82
- M
- UX2 Condenser pump Q9
- M
- UX1 0..10 V Signal
- M
- Z 0..10 V Signal



- AVS75.390
- AVS75.391
- AVS75.370

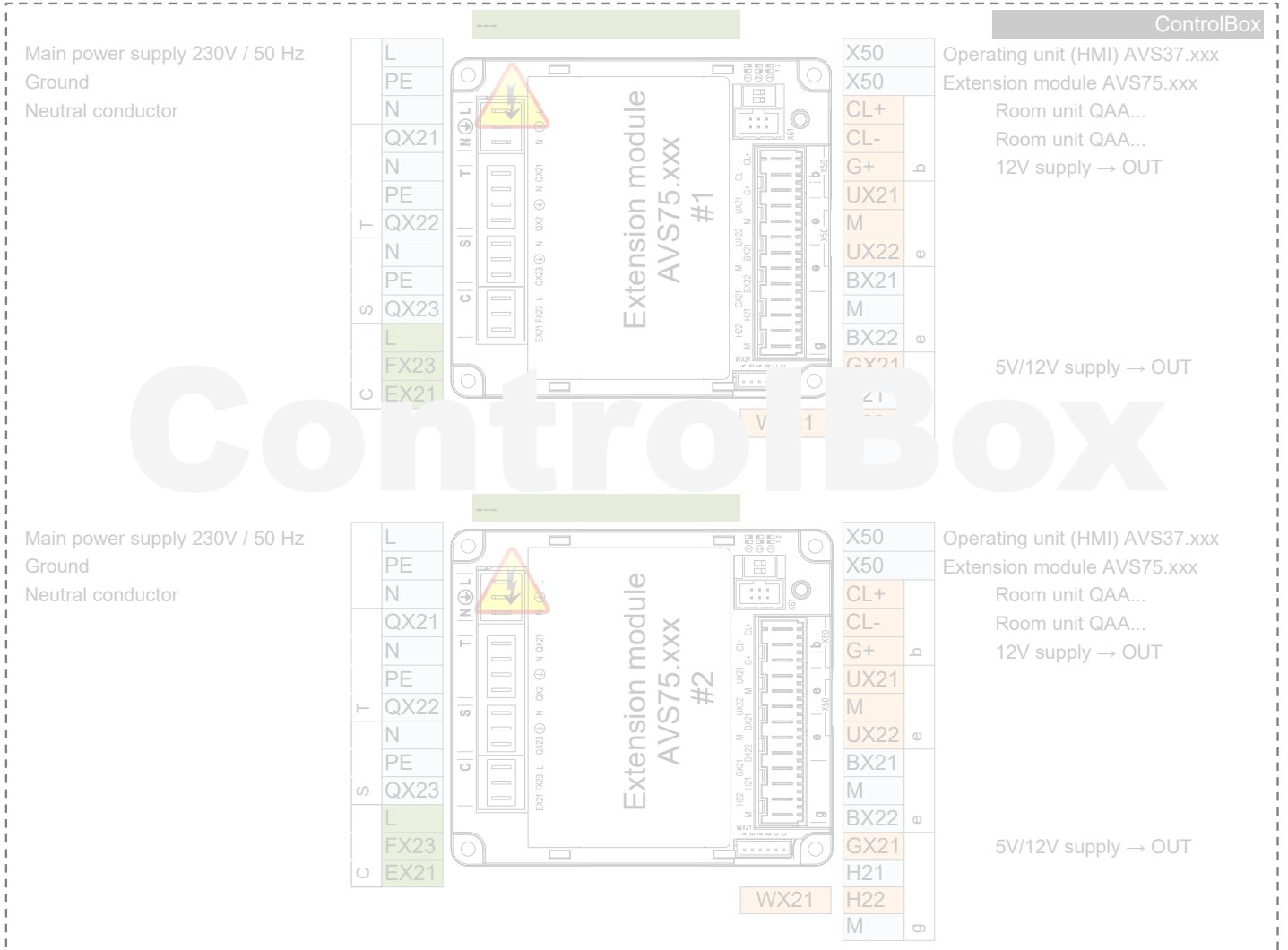

HEAT PUMP

EXTERNAL
INTERNAL

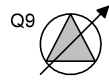
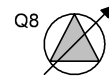

K1

K2

K82

K81

K40

K10

Q8 UX1

Q9 UX2

E11
KRW1
F1K
E11

E12
KRW2
F2K
E12

E6

Q9.ERR
F1S
E24

Q8.ERR
F1Z
E15

E10

E9

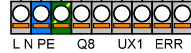
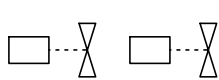

230V,50Hz max 6A

0...10V



DO



0...10V



DO



0...10V



DO



0...10V



DO



0...10V



DO



0...10V



DO



0...10V



DO



0...10V



DO



0...10V



DO



0...10V



DO



0...10V



DO



0...10V



DO

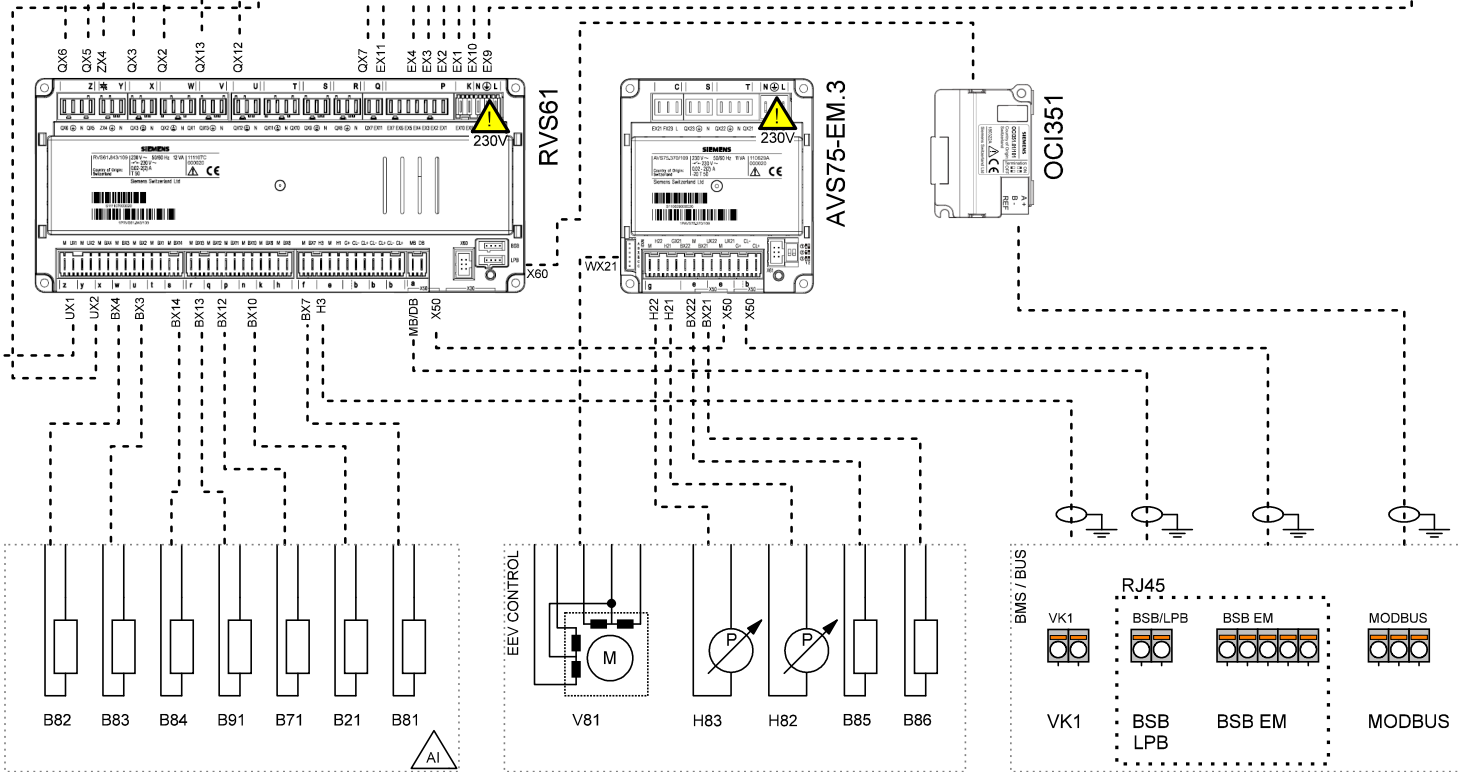
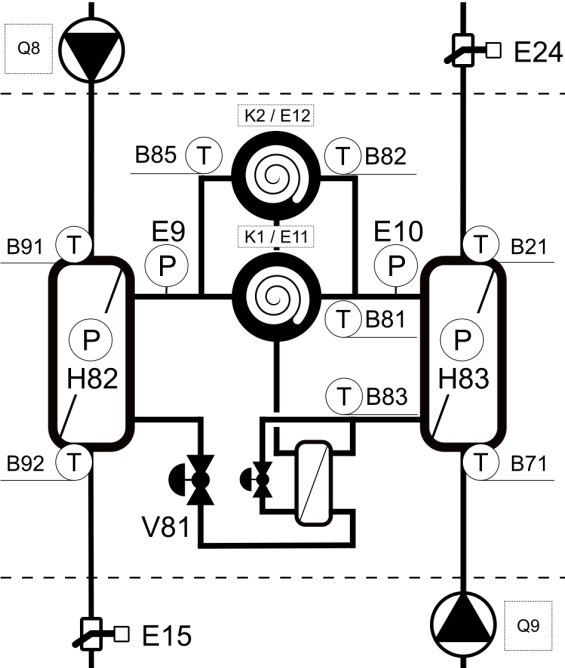

PWR SPLY: 3~ 400V, 50 Hz
CTRL: 1~ 230V, 50 HZ

Company	Title	Version / Note	Number	Created by	Date	Page
	TBW-TWW	05/2024				1

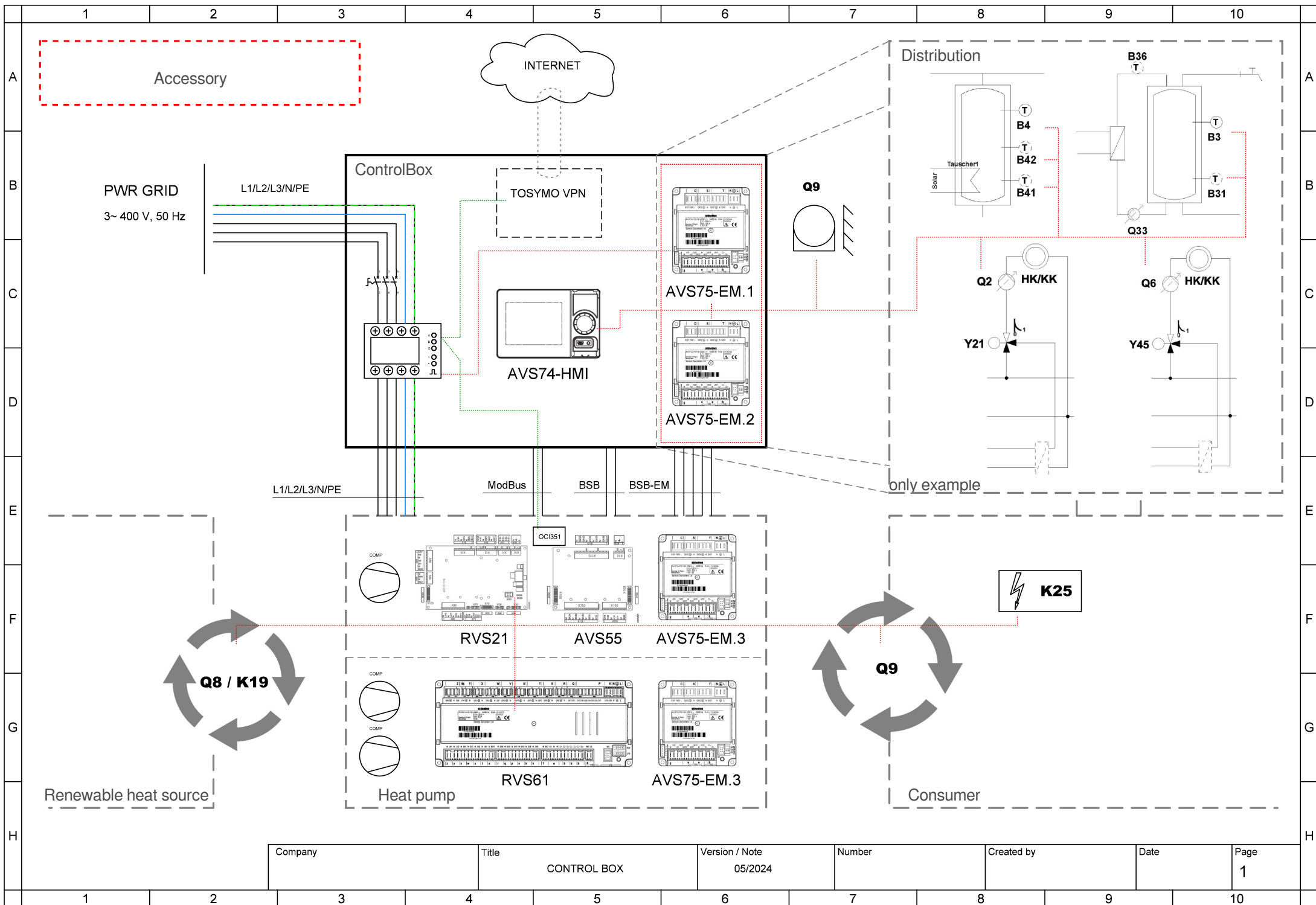

Company	Title	Version / Note	Number	Created by	Date	Page
	CONTROL BOX	05/2024				1



Company	Title	Version / Note	Number	Created by	Date	Page
	CONTROL BOX	05/2024				2



Company	Title	Version / Note	Number	Created by	Date	Page
	CONTROL BOX	05/2024				3



Company	Title	Version / Note	Number	Created by	Date	Page
	CONTROL BOX	05/2024				4

- AVS75.390
- AVS75.391
- AVS75.370

- AVS75.370**
 Main power supply 230V / 50 Hz
 Ground
 Neutral conductor
Y1 Mixing valve Open

Y2 Mixing valve Close

Q2 Heat circuit pump HC1 Q2

L Phase 230V
E61 Smart grid E61

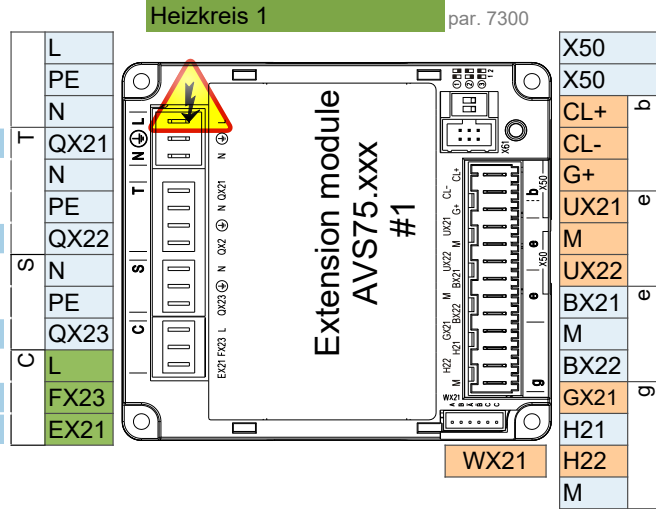

- Extension module AVS75.xxx
 Room unit QAA...
 Room unit QAA...

B1 Flow sensor 1

 Pulse count

- AVS75.370**
 Main power supply 230V / 50 Hz
 Ground
 Neutral conductor
Q3 DHW ctrl elem Q3

K6 El imm heater DHW K6

Q6 Heat circuit pump HC2 Q6

L Phase 230V
E62 Smart grid E62

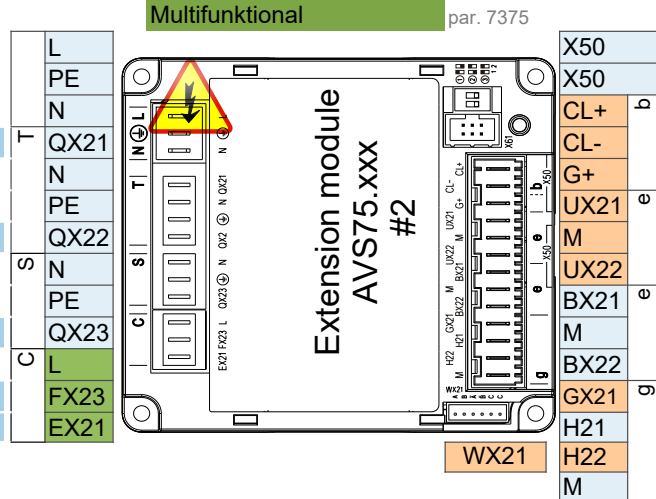

- Operating unit (HMI) AVS37.xxx
 Extension module AVS75.xxx
 Room unit QAA...
 Room unit QAA...

B3 DHW sensor B3

B4 Buffer sensor B4

- Main power supply 230V / 50 Hz
 Ground
 Neutral conductor

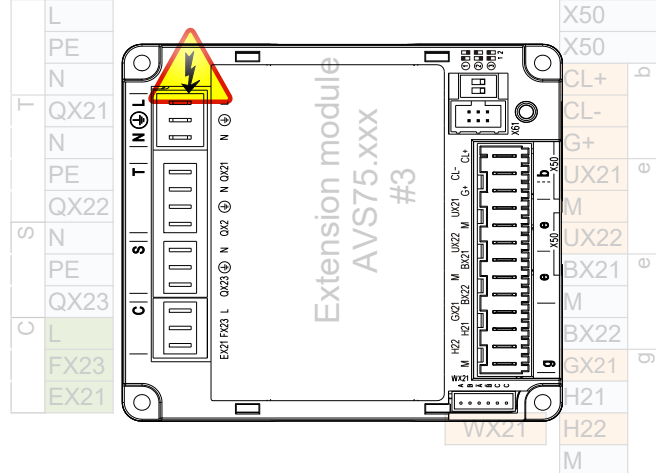

- Operating unit (HMI) AVS37.xxx
 Extension module AVS75.xxx
 Room unit QAA...
 Room unit QAA...

Attention: Extension module 3 is inside the heat pump

Control connection options

1 ControlBox

ControlBox, with two built-in extension modules, enables numerous options for application control on the consumer side behind the heat pump. For more, see the ControlBox schematic and the application diagrams sheet.

2 Fix flow temperature setpoint - On / Off dry (potential free) contact

2 wire shielded cable 2 x 0.5 mm² - Setpoint = 45°C (editable by param. 1859)

Connection terminal - see wiring diagram

3 Analog 0..10V flow temperature setpoint control

2 wire shielded cable 2 x 0.5 mm² - Setpoint: 0V = 16°C ~ 10V = 60°C (editable in parameter set)

Connection terminal - see wiring diagram

4 ModBus RTU communication command

3 wire shielded cable min. 3 x 0.25mm²

For ModBus mapping table contact technical support

5 MQTT IoT communication protocol

For more information contact technical support