



## Wärmepumpe



# TWW 105 EVI

# WAMAK TWW 105 EVI

## Beschreibung des Produkts

---

Wärmepumpe mit zwei Leistungsstufen für Heizung und Warmwasser mit der Möglichkeit einer passiven Kühlregelung. Ein kurzer geschlossener Kältemittelkreislauf mit zwei leisen Scroll-Verdichtern und robusten Plattenwärmetauschern aus Edelstahl. Mit dem Anschlusskit können die Umwälzpumpen einfach und schnell angeschlossen werden, während ihre variable Drehzahl extern gesteuert wird

Verwendung für Mehrfamilienhäuser, gemischt genutzte Vorstadtgebäude oder Gewerbebetriebe. Die URBAN-Reihe basiert auf einer robusten Konstruktion gefertigt aus hochwertigen Stahl. Hochwertige, langjährig bewährte Komponenten des Wärmepumpenkreislaufs verlängern die Lebensdauer der Wärmepumpe.

Als primäre Quelle wird thermische Energie aus unterirdischem Wasser in einer Tiefe von 12 bis 30 Metern genutzt. Eine Tauchpumpe fördert das Grundwasser zur Wärmepumpe und je nach Qualität und chemischer Zusammensetzung wird das Grundwasser entweder direkt in der Wärmepumpe oder über einen vorgefertigten Wärmetauscher mit Zwischenkreislauf und Frostschutzmittel entnommen. Die Wärmepumpe hebt diese Temperatur dann auf eine nutzbare Temperatur für Heizung oder Warmwasser an.

Die EVI-Technologie (Enhanced Vapour Injection) ermöglicht es der Wärmepumpe, auch bei niedrigen Quelltemperaturen höhere Heizungswasser Vorlauftemperaturen zu erreichen. EVI wirkt sich auch auf die Lebensdauer des Kompressors und des gesamten Systems aus, da die Heissgastemperatur des Verdichters niedriger ist.

Die Doppelverdichter verleihen dem System Robustheit und die Fähigkeit, die Wärmeleistung entsprechend der tatsächlichen Belastung zu verteilen.

## Produkt Besonderheiten

---

- Scroll Verdichter
- EVI Technologie
- Asymetrischer Platten- Wärmetauscher
- Mehrstufige Leistungsregelung
- Hochdruck Schalter
- Niederdruck Sensor - analog
- Durchflusssensor Abgabe - analog - (mit Zubehör)
- Regelung von gemischtem Heiz/Kuhl- Kreis
- Steuerung von BWW Umschaltung
- Außentemperaturfühler - (mit Zubehör)
- Puffer Temperaturfühler - (mit Zubehör)
- Modbus Anschluss - (mit Zubehör)
- Sylomer pads unter Verdichter
- Elektronischer Expansionsventil
- Zweistufige Leistungsregelung
- Phasen- und Drehfeldüberwachung
- Hochdruck Sensor - analog
- Durchflussschalter Abgabe - Ein/Aus - (mit Zubehör)
- Durchflussschalter Quelle - Ein/Aus - (mit Zubehör)
- Regelung von direktem Heiz/Kuhl- Kreis
- Steuerung von BWW Zirkulation
- BWW Temperaturfühler - (mit Zubehör)
- Kasladesteuerung - (mit Zubehör)
- Massiver Unterstellrahmen

## Grundlegende Leistungsdaten - WAMAK TWW 105 EVI

Heizen - EN 14511		
Wärmeleistung [kW]	W10 / W35 (max)	109.1 ( 54.5 / 109.1 )
	W10 / W35 (min)	54.5 ( 54.5 / 109.1 )
	W10 / W34	109.1 ( 54.6 / 109.1 )
Leistungsaufnahme [kW]	W10 / W35 (max)	18.9 ( 9.3 / 18.9 )
	W10 / W35 (min)	9.3 ( 9.3 / 18.9 )
	W10 / W34	18.5 ( 13.3 / 27.1 )
Leistungszahl Heizen [COP]	W10 / W35 (max)	5.78
	W10 / W35 (min)	5.86
	W10 / W34	5.90
Jahreszeitbedingte Raumheizungs-Energieeffizienz - SCOP EN 14825		
Klimazone Durchschnitt / Niedrigtemp. [35 °C]	SCOP	6.52
	$\eta$ [ % ]	260.9
	Label	A+++
	Qhe [ kWh ]	34506.5
	Pdesignh [ kW ]	109.1
	Tbivalent [ °C ]	-10
Kühlung		
Kühlleistung - [kW]	A35 / W23-18	85.3
	A25 / W23-18	89.7
	A35 / W12-7	62.9
	A25 / W12-7	62.9
Jahreszeitbedingte Raumkühlungs-Energieeffizienz - SEER EN 14825		
[ W 23 / 18 °C ]	SEER	5.23
	Qce [ kWh ]	9075.5
	$\eta_c$ [ % ]	209.2
Schall EN 12102		
Schallleistungspegel - Lw	dB(A)	64.4
Schalldruckpegel - Lp	1 m dB(A)	56.4
	5 m dB(A)	42.4
	10 m dB(A)	36.4
Mechanische und Betriebs-Informationen		
Verdichterbauart (3~ 400/50)	SCROLL / 2 /	Ein/Aus
Kältemittel	R410A (GWP - 2088)	10.6 kg
Einsatzgrenze Heizungswasser - (min / max ) [ °C ]		25 / 65
Einsatzgrenze Wärmequelle - (min / max ) [ °C ]		-10 (7) / 30
Gewicht		445 kg

## Wichtigste technische Daten - WAMAK TWW 105 EVI

Gehäuse Bezeichnung		VN1100		Daten von Wärmeabgabe	
<b>Grundlegende Abmessungen</b>	Hohe [mm]	1270		Einsatzgrenze Heizungswasser	MAX [°C] 65
	Breite [mm]	1100			MIN [°C] 25
	Länge [mm]	750		genauer siehe Betriebsgrenzendiagramm	
Gewicht [kg]	445		<b>Kondensator</b>	Anschlussdimension	VIC 2.1/2 "
Gehäuse Farbe	Grau			Bauart	BPHE
Gehäuse IP Klasse	IP20			Anzahl	1
				Material	AISI 316
<b>Kältekreis</b>					
<b>Verdichter</b>	Bauart	Scroll		Maximaler Überdruck - Kältemittel [bar] 50	
	Leistungstufen	2		Maximaler Überdruck - Wasser [bar] 6	
	Ein/Aus			Prüfdruck [bar] 70	
	Leistungsfaktor Cosφ	0.59		Wärmeträger Wasser	
	Wicklungswiderstand	0.83 Ohm		Volumenstrom @ dT 5K (nom) - Wasser [m3/h] 9.43 ~ 18.86	
Kältemittel		R410A		Interne Druckdifferenz - Wasser [kPa] 20	
	Menge	10.6 kg		Temperaturdifferenz @ 35°C (nom)	5 K
	GWP	2088		@ 55°C	8 K
	Sicherheitsklasse	A1		@ 65°C	10 K
Kältemittelöl	POE RL32-3MAF			<b>Daten von Erneuerbarer Energiequelle</b>	
	Ölmenge	2 x 3.38 L		Einsatzgrenze Wärmequelle	MIN [°C] -10 (7)
Maximaler Hochdruck - Kältemittel [bar]		50			MAX [°C] 30
	PED Klasse	2		genauer siehe Betriebsgrenzendiagramm	
EVI - Dampfeinspritzung mit Economiser			<b>Verdampfer</b>	Anschlussdimension	VIC 2.1/2 "
				Bauart	BPHE
				Anzahl	1
				Material	AISI 316
			Maximaler Überdruck - Kältemittel [bar] 29		
			Wärmeträger Wasser		
			Maximaler Überdruck - Wasser [bar] 6		
			Volumenstrom - Wasser [m3/h] 9.75 ~ 19.50		
			Interne Druckdifferenz - Wasser [kPa] 20		
			Temperaturdifferenz - Wasser 4 K		
<b>Daten von Elektroanschluss</b>					
Einspeisung [#~ V/Hz]		3~ 400/50			
Strom	Nominal [A]	43.28			
	Maximal [A]	66.00			
	Start [A]	58.42			
Sanftanlasser			-		
Hauptsicherung		C80			
<b>Steuerungssystem</b>					
Hauptregler	SIEMENS	RVS 61			
Erweiterungsmo dul	AVS75.3xx	AVS75.3xx	AVS75.372		
Bus Clip-In			Modbus OCI353		
Online-Verbindung	Web server OZW672		ToSyMo		
EEV Regelung		SEC61			

\*\*\* mit Zubehör

# WAMAK TWW 105 EVI

## ErP (EU) No 811/2013: Technische Parameter für Wärmepumpen-Raumheizgeräte

Modell	TWW 105 EVI
Luft-Wasser-Wärmepumpe	nein
Sole/Wasser-Wärmepumpe	nein
Wasser/Wasser-Wärmepumpe	ja
Niedertemperatur-Wärmepumpe	nein
Ausgestattet mit einer Zusatzheizung	nein
Wärmepumpen-Kombi-Heizgerät	nein
Temperaturanwendung	niedrig (35 °C - 30 °C)
Klimaverhältnisse	durchschnittlich

Angabe	Symbol	Wert	Ein.	Angabe	Symbol	Wert	Ein.
Nennwärmeleistung bei Tdesignh	Prated	109.1	kW	Jahreszeitbedingte Raumheizungs-Energieeffizienz	$\eta_s$	260.9	%
Ausgewiesene Heizleistung für Teillast bei einer Innentemperatur von 20 °C und einer Außentemperatur von Tj				Deklarierte Leistungszahl oder Primärenergiekennzahl für Teillast bei einer Innentemperatur von 20 °C und einer Außentemperatur von Tj			
Tj = -7 °C	Pdh	109.1	kW	Tj = -7 °C	COPd	5.90	-
Tj = +2 °C	Pdh	109.4	kW	Tj = +2 °C	COPd	6.4	-
Tj = +7 °C	Pdh	109.5	kW	Tj = +7 °C	COPd	6.9	-
Tj = +12 °C	Pdh	109.6	kW	Tj = +12 °C	COPd	7.4	-
Tj = bivalente Temperatur	Pdh	109.1	kW	Tj = bivalente Temperatur	COPd	5.8	-
Tj = Betriebsgrenztemperatur	Pdh	---	kW	Tj = Betriebsgrenztemperatur	COPd	---	-
Bivalente Temperatur	Tbiv	-10	°C	Tj = Betriebsgrenztemperatur	TOL	---	°C
Stromverbrauch in anderen Modi als dem aktiven Modus				Betriebsgrenztemperatur des Heizwassers			
Aus-Zustand	Poff	0.010	kW	Zusatzheizung			
Thermostat-Aus-Modus	Pto	0.010	kW	Nennwärmeleistung	Psup	16.4	kW
Standby-Betrieb	Psb	0.010	kW	Art der Energiezufuhr			
Betriebsart Kurbelwannenheizung	Pck	0.000	kW	elektrisch			
Sonstige Angaben				Für Luft/Wasser-Wärmepumpen: Nennluftvolumenstrom, Außenbereich			
Leistungsregelung		mehrstufig		Für Wasser- oder Sole/Wasser-Wärmepumpen: Nenndurchfluss der Sole oder des Wassers, Wärmetauscher im Freien			
Schalleistungspegel							
in Innenräumen	Lwa	64	dB				
im Freien	Lwa	---	dB				
Jährlicher Energieverbrauch	Q <sub>HE</sub>	34506.5	kWh				

**Angaben zum Kontakt:** WAMAK, s.r.o., Orovnic 252, 96652, Orovnic, Slovakia, info@wamak.sk

# WAMAK TWW 105 EVI

## ErP (EU) No 811/2013: Technische Parameter für Wärmepumpen-Raumheizgeräte

Modell	TWW 105 EVI
Luft-Wasser-Wärmepumpe	nein
Sole/Wasser-Wärmepumpe	nein
Wasser/Wasser-Wärmepumpe	ja
Niedertemperatur-Wärmepumpe	nein
Ausgestattet mit einer Zusatzheizung	nein
Wärmepumpen-Kombi-Heizgerät	nein
Temperaturanwendung	mittel (55 °C - 47 °C)
Klimaverhältnisse	durchschnittlich

Angabe	Symbol	Wert	Ein.	Angabe	Symbol	Wert	Ein.
Nennwärmeleistung bei Tdesignh	Prated	108.9	kW	Jahreszeitbedingte Raumheizungs-Energieeffizienz	$\eta_s$	202.6	%
Ausgewiesene Heizleistung für Teillast bei einer Innentemperatur von 20 °C und einer Außentemperatur von Tj				Deklarierte Leistungszahl oder Primärenergiekennzahl für Teillast bei einer Innentemperatur von 20 °C und einer Außentemperatur von Tj			
Tj = -7 °C	Pdh	109.9	kW	Tj = -7 °C	COPd	4.06	-
Tj = +2 °C	Pdh	110.1	kW	Tj = +2 °C	COPd	5.2	-
Tj = +7 °C	Pdh	110.4	kW	Tj = +7 °C	COPd	6.0	-
Tj = +12 °C	Pdh	110.7	kW	Tj = +12 °C	COPd	6.6	-
Tj = bivalente Temperatur	Pdh	108.9	kW	Tj = bivalente Temperatur	COPd	3.7	-
Tj = Betriebsgrenztemperatur	Pdh	---	kW	Tj = Betriebsgrenztemperatur	COPd	---	-
Bivalente Temperatur	Tbiv	-10	°C	Tj = Betriebsgrenztemperatur	TOL	---	°C
<b>Stromverbrauch in anderen Modi als dem aktiven Modus</b>				Betriebsgrenztemperatur des Heizwassers	WTOL	65	°C
Aus-Zustand	Poff	0.010	kW	<b>Zusatzheizung</b>			
Thermostat-Aus-Modus	Pto	0.010	kW	Nennwärmeleistung	Psup	16.4	kW
Standby-Betrieb	Psb	0.010	kW	Art der Energiezufuhr	elektrisch		
Betriebsart Kurbelwannenheizung	Pck	0.000	kW	<b>Sonstige Angaben</b>			
Leistungsregelung				mehrstufig			
Schalleistungspegel				Für Luft/Wasser-Wärmepumpen: - --- m3/h Nennluftvolumenstrom, Außenbereich			
in Innenräumen	Lwa	64	dB	Für Wasser- oder Sole/Wasser-Wärmepumpen: Nenndurchfluss der Sole oder des Wassers, Wärmetauscher im Freien			
im Freien	Lwa	---	dB	- 9.75 ~ 19.50 m3/h			
Jährlicher Energieverbrauch	QHE	44382.2	kWh				

**Angaben zum Kontakt:** WAMAK, s.r.o., Orovnica 252, 96652, Orovnica, Slovakia, info@wamak.sk



**ENERG** Y IIA  
 енергия - ενεργεια IE IA

**WAMAK**

TWW 105 EVI



55 °C

35 °C



**A+++**

**A+++**



64 dB



--- dB

■ 115  
 ■ 109  
 ■ 107  
 kW

■ 112  
 ■ 110  
 ■ 104  
 kW



2019

811/2013

TWW 105 EVI

**ErP Data**

	55 °C	35 °C
Energy class	<b>A+++</b>	<b>A+++</b>
$\eta$ [%]	202.6	260.9
$P_{rated}$ [kW]	109	110
$Q_{HE}$ [kWh/y]	44383	34507
SCOP [-]	5.06	6.52
$T_{bivalent}$ [°C]	-10	-10

CONTROLLER



+ QAA55/75  
 - QAA55/75

class VII  
 class III

3.5% ↓  
 1.5% ↓

Heizleistung Daten

Version: v2024.010-BW-WW

Quelle - Sole [0°C] / Niedrigtemp. [35°C]

ZHI40K1P-TFD\_R410A\_2\_BWW

Betriebsbedingungen	Qh	P	COP
1 B0 / W30-35	85.5	18.7	4.57
2 B0 / W30-35 ( MIN )	42.8	9.2	4.64
A B0 / Wxx-34	85.5	18.3	4.67
B B0 / Wxx-30	85.5	16.9	5.06
C B0 / Wxx-27	42.7	7.8	5.45
D B0 / Wxx-24	42.7	7.4	5.78
E B0 / Wxx-35	85.5	18.7	4.57
F B0 / Wxx-35	85.5	18.7	4.57

SCOP DATA EN 14825:2018	
Quelle - Sole [0°C] / Niedrigtemp. [35°C]	
SCOPon	5.15
SCOPnet	5.15
SCOP	5.15
η [ % ]	205.90
Label	A+++
Qh [ kWh ]	34272
Pdesignh [ kW ]	85.5
Tbivalent [ °C ]	-10

Quelle - Sole [0°C] / Mitteltemp.. [55°C]

Betriebsbedingungen	Qh	P	COP
1 B0 / W47-55	87.0	29.5	2.94
2 B0 / W47-55 ( MIN )	43.5	14.4	2.98
A B0 / Wxx-52	87.4	26.8	3.37
B B0 / Wxx-42	87.8	20.8	4.26
C B0 / Wxx-36	43.3	9.1	4.74
D B0 / Wxx-30	43.3	8.3	5.20
E B0 / Wxx-55	87.0	29.5	2.94
F B0 / Wxx-54	87.5	27.5	3.19

SCOP DATA EN 14825:2018	
Quelle - Sole [0°C] / Mitteltemp.. [55°C]	
SCOPon	4.13
SCOPnet	4.13
SCOP	4.12
η [ % ]	164.93
Label	A+++
Qh [ kWh ]	43546
Pdesignh [ kW ]	87.0
Tbivalent [ °C ]	-10

Quelle - Wasser [10°C] / Niedrigtemp. [35°C]

Betriebsbedingungen	Qh	P	COP
1 W10 / W30-35	109.1	18.9	5.78
2 W10 / W30-35 ( MIN )	54.5	9.3	5.86
A W10 / Wxx-34	109.1	18.5	5.90
B W10 / Wxx-30	109.4	17.0	6.42
C W10 / Wxx-27	109.5	16.0	6.92
D W10 / Wxx-24	109.6	15.1	7.35
E W10 / Wxx-35	109.1	18.9	5.78
F W10 / Wxx-35	109.1	18.9	5.78

SCOP DATA EN 14825:2018	
Quelle - Wasser [10°C] / Niedrigtemp. [35°C]	
SCOPon	6.53
SCOPnet	6.53
SCOP	6.52
η [ % ]	260.94
Label	A+++
Qh [ kWh ]	34507
Pdesignh [ kW ]	109.1
Tbivalent [ °C ]	-10.00

**Quelle - Wasser [10°C] / Mitteltemp. [55°C]**

Betriebsbedingungen		Qh	P	COP
1	W10 / W47-55	108.9	29.8	3.66
2	W10 / W47-55 ( MIN )	54.5	14.7	3.71
A	W10 / Wxx-52	109.9	27.1	4.06
B	W10 / Wxx-42	110.1	21.0	5.24
C	W10 / Wxx-36	110.4	18.7	5.99
D	W10 / Wxx-30	110.7	17.1	6.58
E	W10 / Wxx-55	108.9	29.8	3.66
F	W10 / Wxx-55	108.9	29.8	3.66

SCOP DATA EN 14825:2018	
Quelle - Wasser [10°C] / Mitteltemp. [55°C]	
SCOPon	5.07
SCOPnet	5.07
SCOP	5.06
η [ % ]	202.56
Label	A+++
Qh [ kWh ]	44382
Pdesignh [ kW ]	108.9
Tbivalent [ °C ]	-10.00

**Niedrigtemperatur Kühlung W 12 / 7°C**

Betriebsbedingungen		Qc	P	EER
A	W30-35 / W12-7	64.9	19.9	3.26
B	W26-xx / W12-7	66.3	18.3	3.62
C	W22-xx / W12-7	67.6	16.9	4.01
D	W18-xx / W12-7	68.2	16.2	4.21

SEER DATA EN 14825:2018 [ W 12 / 7°C ]	
SEERon	3.89
SEER	3.89
Qc [ kWh ]	37740
η [ % ]	155.45

**Flächenkühlung W 23 / 18°C**

Betriebsbedingungen		Qc	P	EER
A	W50-xx / W23-18	76.9	31.8	2.42
B	W40-xx / W23-18	82.7	24.9	3.32
C	W30-35 / W23-18	87.6	19.9	4.40
D	W26-xx / W23-18	89.3	18.3	4.88

SEER DATA EN 14825:2018 [ W 23 / 18°C ]	
SEERon	5.23
SEER	5.23
Qc [ kWh ]	37740
η [ % ]	209.16

Leistungslinien - Heizen

- Qh-nom-35    - - - Qh-min-35    - - - - Qh-max-65    — Qh-nom-45    — Qh-nom-55
- Qh-nom-65

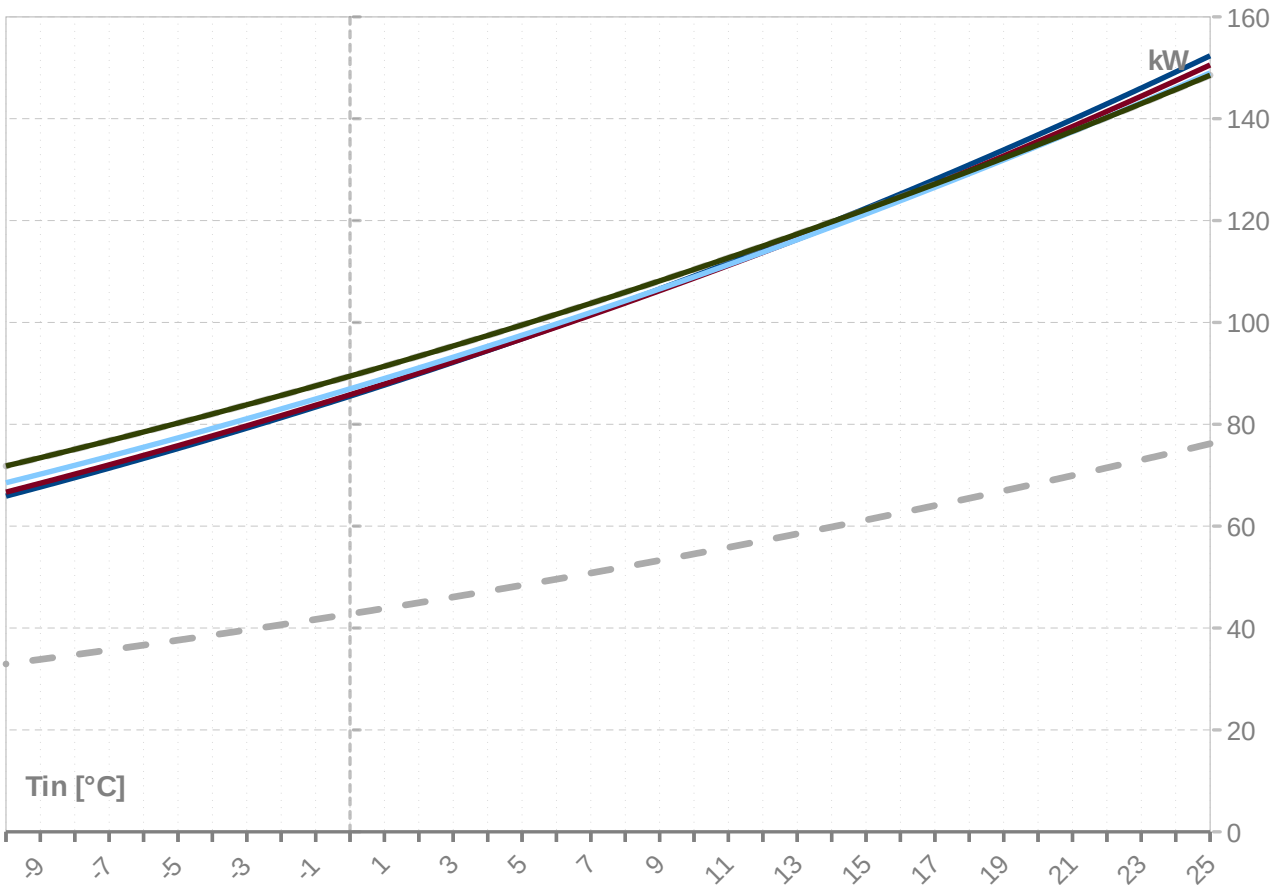

Leistungslinien - Kühlen

- Qc-nom-12-7    — Qc-nom-23-18

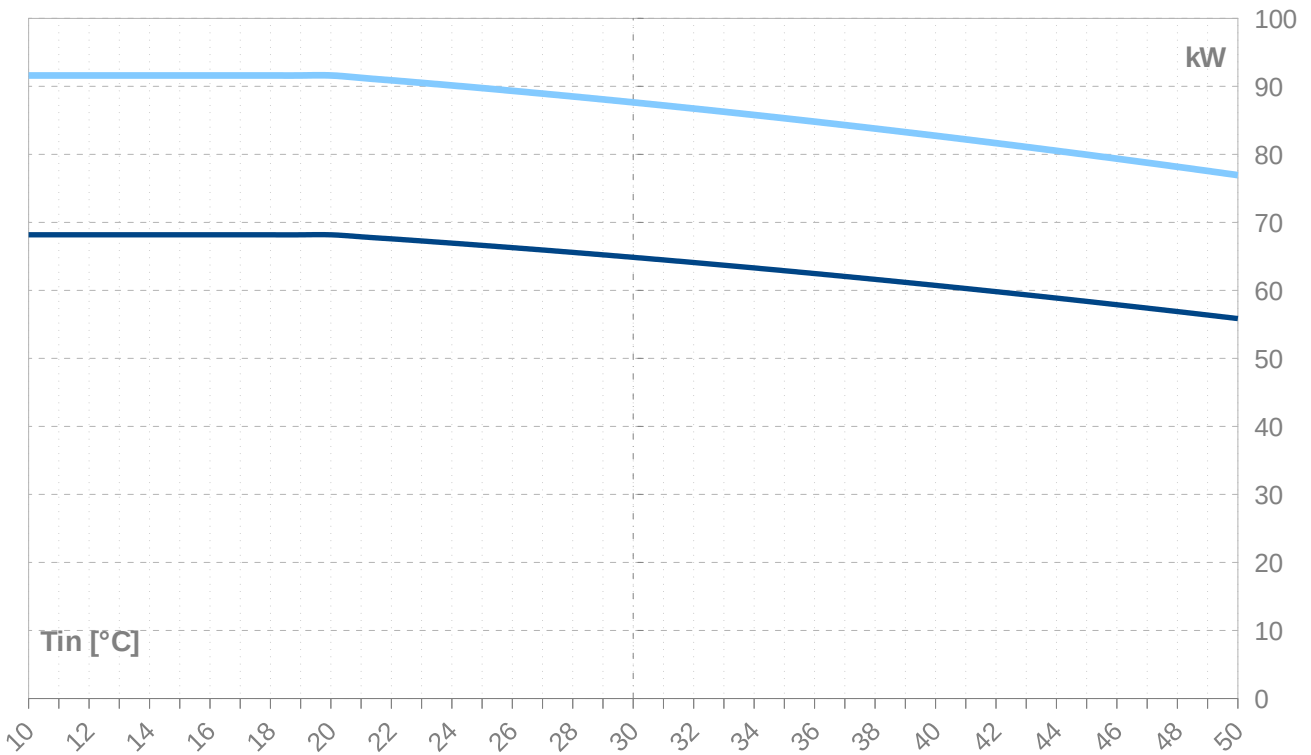

Tws -VL		35										
	[°C]	Qh nom	Qh min	Qh max	Pin nom	Pin min	Pin max	COP nom	Qc nom	Qc min	Qc max	I nom
Twq -RL	[°C]	[kW]	[kW]	[kW]	[kW]	[kW]	[kW]	kw / kw	[kW]	[kW]	[kW]	[A]
25	<b>152.3</b>	76.2	152.3	<b>19.2</b>	9.5	19.2	<b>7.94</b>	134.4	67.2	134.4	43.2	
24	<b>149.2</b>	74.6	149.2	<b>19.2</b>	9.5	19.2	<b>7.78</b>	131.3	65.6	131.3	43.2	
23	<b>146.0</b>	73.0	146.0	<b>19.2</b>	9.4	19.2	<b>7.62</b>	128.1	64.1	128.1	43.2	
22	<b>142.9</b>	71.5	142.9	<b>19.1</b>	9.4	19.1	<b>7.47</b>	125.0	62.5	125.0	43.2	
21	<b>139.8</b>	69.9	139.8	<b>19.1</b>	9.4	19.1	<b>7.32</b>	122.0	61.0	122.0	43.2	
20	<b>136.8</b>	68.4	136.8	<b>19.1</b>	9.4	19.1	<b>7.17</b>	119.0	59.5	119.0	43.3	
19	<b>133.9</b>	66.9	133.9	<b>19.1</b>	9.4	19.1	<b>7.02</b>	116.1	58.0	116.1	43.3	
18	<b>130.9</b>	65.5	130.9	<b>19.0</b>	9.4	19.0	<b>6.87</b>	113.1	56.6	113.1	43.3	
17	<b>128.1</b>	64.0	128.1	<b>19.0</b>	9.4	19.0	<b>6.73</b>	110.3	55.1	110.3	43.3	
16	<b>125.2</b>	62.6	125.2	<b>19.0</b>	9.4	19.0	<b>6.59</b>	107.5	53.7	107.5	43.4	
15	<b>122.4</b>	61.2	122.4	<b>19.0</b>	9.4	19.0	<b>6.45</b>	104.7	52.3	104.7	43.4	
14	<b>119.7</b>	59.8	119.7	<b>19.0</b>	9.4	19.0	<b>6.31</b>	102.0	51.0	102.0	43.4	
13	<b>117.0</b>	58.5	117.0	<b>18.9</b>	9.3	18.9	<b>6.17</b>	99.3	49.6	99.3	43.4	
12	<b>114.3</b>	57.1	114.3	<b>18.9</b>	9.3	18.9	<b>6.04</b>	96.6	48.3	96.6	43.5	
11	<b>111.7</b>	55.8	111.7	<b>18.9</b>	9.3	18.9	<b>5.91</b>	94.0	47.0	94.0	43.5	
10	<b>109.1</b>	54.5	109.1	<b>18.9</b>	9.3	18.9	<b>5.78</b>	91.5	45.7	91.5	43.5	
9	<b>106.5</b>	53.3	106.5	<b>18.9</b>	9.3	18.9	<b>5.65</b>	88.9	44.5	88.9	43.5	
8	<b>104.1</b>	52.0	104.1	<b>18.8</b>	9.3	18.8	<b>5.52</b>	86.5	43.2	86.5	43.5	
7	<b>101.6</b>	50.8	101.6	<b>18.8</b>	9.3	18.8	<b>5.40</b>	84.0	42.0	84.0	43.5	
6	<b>99.2</b>	49.6	99.2	<b>18.8</b>	9.3	18.8	<b>5.27</b>	81.6	40.8	81.6	43.5	
5	<b>96.8</b>	48.4	96.8	<b>18.8</b>	9.3	18.8	<b>5.15</b>	79.3	39.6	79.3	43.6	
4	<b>94.5</b>	47.2	94.5	<b>18.8</b>	9.3	18.8	<b>5.03</b>	76.9	38.5	76.9	43.6	
3	<b>92.2</b>	46.1	92.2	<b>18.8</b>	9.2	18.8	<b>4.92</b>	74.7	37.3	74.7	43.6	
2	<b>89.9</b>	45.0	89.9	<b>18.7</b>	9.2	18.7	<b>4.80</b>	72.4	36.2	72.4	43.6	
1	<b>87.7</b>	43.9	87.7	<b>18.7</b>	9.2	18.7	<b>4.69</b>	70.2	35.1	70.2	43.6	
0	<b>85.5</b>	42.8	85.5	<b>18.7</b>	9.2	18.7	<b>4.57</b>	68.1	34.0	68.1	43.6	
-1	<b>83.4</b>	41.7	83.4	<b>18.7</b>	9.2	18.7	<b>4.46</b>	65.9	33.0	65.9	43.6	
-2	<b>81.3</b>	40.6	81.3	<b>18.7</b>	9.2	18.7	<b>4.35</b>	63.9	31.9	63.9	43.6	
-3	<b>79.2</b>	39.6	79.2	<b>18.7</b>	9.2	18.7	<b>4.25</b>	61.8	30.9	61.8	43.6	
-4	<b>77.2</b>	38.6	77.2	<b>18.6</b>	9.2	18.6	<b>4.14</b>	59.8	29.9	59.8	43.6	
-5	<b>75.2</b>	37.6	75.2	<b>18.6</b>	9.2	18.6	<b>4.04</b>	57.8	28.9	57.8	43.6	
-6	<b>73.3</b>	36.6	73.3	<b>18.6</b>	9.2	18.6	<b>3.94</b>	55.9	28.0	55.9	43.6	
-7	<b>71.4</b>	35.7	71.4	<b>18.6</b>	9.2	18.6	<b>3.84</b>	54.0	27.0	54.0	43.6	
-8	<b>69.5</b>	34.8	69.5	<b>18.6</b>	9.2	18.6	<b>3.74</b>	52.2	26.1	52.2	43.6	
-9	<b>67.7</b>	33.8	67.7	<b>18.6</b>	9.2	18.6	<b>3.65</b>	50.3	25.2	50.3	43.6	
-10	<b>65.9</b>	32.9	65.9	<b>18.6</b>	9.2	18.6	<b>3.55</b>	48.6	24.3	48.6	43.5	
-11	<b>64.1</b>	32.1	64.1	<b>18.5</b>	9.1	18.5	<b>3.46</b>	46.8	23.4	46.8	43.5	
-12	<b>62.4</b>	31.2	62.4	<b>18.5</b>	9.1	18.5	<b>3.37</b>	45.1	22.6	45.1	43.5	
-13	<b>60.7</b>	30.4	60.7	<b>18.5</b>	9.1	18.5	<b>3.28</b>	43.4	21.7	43.4	43.5	
-14	<b>59.1</b>	29.5	59.1	<b>18.5</b>	9.1	18.5	<b>3.19</b>	41.8	20.9	41.8	43.4	
-15	<b>57.5</b>	28.7	57.5	<b>18.5</b>	9.1	18.5	<b>3.10</b>	40.2	20.1	40.2	43.4	

-- Achtung: Betriebsgrenzen beachten - nicht in Tabelle festgehalten

ZHI40K1P-TFD\_R410A\_2\_BWW

Tws -VL	45										
[°C]	Qh nom	Qh min	Qh max	Pin nom	Pin min	Pin max	COP nom	Qc nom	Qc min	Qc max	I nom
[°C]	[kW]	[kW]	[kW]	[kW]	[kW]	[kW]	kW / kW	[kW]	[kW]	[kW]	[A]
25	<b>150.5</b>	75.3	150.5	<b>23.6</b>	11.7	23.6	<b>6.37</b>	128.5	64.2	128.5	48.0
24	<b>147.5</b>	73.7	147.5	<b>23.6</b>	11.6	23.6	<b>6.25</b>	125.4	62.7	125.4	48.0
23	<b>144.4</b>	72.2	144.4	<b>23.6</b>	11.6	23.6	<b>6.12</b>	122.4	61.2	122.4	48.0
22	<b>141.4</b>	70.7	141.4	<b>23.6</b>	11.6	23.6	<b>6.00</b>	119.4	59.7	119.4	47.9
21	<b>138.5</b>	69.2	138.5	<b>23.5</b>	11.6	23.5	<b>5.89</b>	116.5	58.2	116.5	47.9
20	<b>135.5</b>	67.8	135.5	<b>23.5</b>	11.6	23.5	<b>5.77</b>	113.6	56.8	113.6	47.9
19	<b>132.7</b>	66.3	132.7	<b>23.5</b>	11.6	23.5	<b>5.65</b>	110.8	55.4	110.8	47.8
18	<b>129.8</b>	64.9	129.8	<b>23.4</b>	11.6	23.4	<b>5.54</b>	108.0	54.0	108.0	47.8
17	<b>127.1</b>	63.5	127.1	<b>23.4</b>	11.5	23.4	<b>5.43</b>	105.2	52.6	105.2	47.8
16	<b>124.3</b>	62.2	124.3	<b>23.4</b>	11.5	23.4	<b>5.32</b>	102.5	51.2	102.5	47.8
15	<b>121.6</b>	60.8	121.6	<b>23.4</b>	11.5	23.4	<b>5.21</b>	99.8	49.9	99.8	47.7
14	<b>118.9</b>	59.5	118.9	<b>23.3</b>	11.5	23.3	<b>5.10</b>	97.2	48.6	97.2	47.7
13	<b>116.3</b>	58.2	116.3	<b>23.3</b>	11.5	23.3	<b>4.99</b>	94.6	47.3	94.6	47.7
12	<b>113.7</b>	56.9	113.7	<b>23.3</b>	11.5	23.3	<b>4.89</b>	92.0	46.0	92.0	47.7
11	<b>111.2</b>	55.6	111.2	<b>23.3</b>	11.5	23.3	<b>4.78</b>	89.5	44.7	89.5	47.6
10	<b>108.7</b>	54.3	108.7	<b>23.2</b>	11.5	23.2	<b>4.68</b>	87.0	43.5	87.0	47.6
9	<b>106.2</b>	53.1	106.2	<b>23.2</b>	11.4	23.2	<b>4.58</b>	84.6	42.3	84.6	47.6
8	<b>103.8</b>	51.9	103.8	<b>23.2</b>	11.4	23.2	<b>4.48</b>	82.2	41.1	82.2	47.6
7	<b>101.4</b>	50.7	101.4	<b>23.2</b>	11.4	23.2	<b>4.38</b>	79.8	39.9	79.8	47.5
6	<b>99.1</b>	49.5	99.1	<b>23.1</b>	11.4	23.1	<b>4.28</b>	77.5	38.7	77.5	47.5
5	<b>96.8</b>	48.4	96.8	<b>23.1</b>	11.4	23.1	<b>4.19</b>	75.2	37.6	75.2	47.5
4	<b>94.5</b>	47.3	94.5	<b>23.1</b>	11.4	23.1	<b>4.09</b>	72.9	36.5	72.9	47.4
3	<b>92.3</b>	46.1	92.3	<b>23.1</b>	11.4	23.1	<b>4.00</b>	70.7	35.4	70.7	47.4
2	<b>90.1</b>	45.0	90.1	<b>23.1</b>	11.4	23.1	<b>3.91</b>	68.6	34.3	68.6	47.4
1	<b>87.9</b>	44.0	87.9	<b>23.0</b>	11.4	23.0	<b>3.82</b>	66.4	33.2	66.4	47.4
0	<b>85.8</b>	42.9	85.8	<b>23.0</b>	11.3	23.0	<b>3.73</b>	64.3	32.2	64.3	47.3
-1	<b>83.7</b>	41.9	83.7	<b>23.0</b>	11.3	23.0	<b>3.64</b>	62.3	31.1	62.3	47.3
-2	<b>81.7</b>	40.8	81.7	<b>23.0</b>	11.3	23.0	<b>3.56</b>	60.2	30.1	60.2	47.3
-3	<b>79.7</b>	39.8	79.7	<b>23.0</b>	11.3	23.0	<b>3.47</b>	58.3	29.1	58.3	47.2
-4	<b>77.7</b>	38.9	77.7	<b>22.9</b>	11.3	22.9	<b>3.39</b>	56.3	28.2	56.3	47.2
-5	<b>75.8</b>	37.9	75.8	<b>22.9</b>	11.3	22.9	<b>3.31</b>	54.4	27.2	54.4	47.2
-6	<b>73.9</b>	36.9	73.9	<b>22.9</b>	11.3	22.9	<b>3.23</b>	52.5	26.3	52.5	47.1
-7	<b>72.0</b>	36.0	72.0	<b>22.9</b>	11.3	22.9	<b>3.15</b>	50.7	25.3	50.7	47.1
-8	<b>70.2</b>	35.1	70.2	<b>22.9</b>	11.3	22.9	<b>3.07</b>	48.8	24.4	48.8	47.1
-9	<b>68.4</b>	34.2	68.4	<b>22.9</b>	11.3	22.9	<b>2.99</b>	47.1	23.5	47.1	47.0
-10	<b>66.7</b>	33.3	66.7	<b>22.9</b>	11.3	22.9	<b>2.92</b>	45.3	22.7	45.3	47.0
-11	<b>65.0</b>	32.5	65.0	<b>22.9</b>	11.3	22.9	<b>2.84</b>	43.6	21.8	43.6	46.9
-12	<b>63.3</b>	31.6	63.3	<b>22.8</b>	11.3	22.8	<b>2.77</b>	41.9	21.0	41.9	46.9
-13	<b>61.6</b>	30.8	61.6	<b>22.8</b>	11.3	22.8	<b>2.70</b>	40.3	20.1	40.3	46.9
-14	<b>60.0</b>	30.0	60.0	<b>22.8</b>	11.3	22.8	<b>2.63</b>	38.7	19.3	38.7	46.8
-15	<b>58.4</b>	29.2	58.4	<b>22.8</b>	11.3	22.8	<b>2.56</b>	37.1	18.6	37.1	46.8

-- Achtung: Betriebsgrenzen beachten - nicht in Tabelle festgehalten

Tws -VL		55										
	[°C]	Qh nom	Qh min	Qh max	Pin nom	Pin min	Pin max	COP nom	Qc nom	Qc min	Qc max	I nom
Twq -RL	[°C]	[kW]	[kW]	[kW]	[kW]	[kW]	[kW]	kw / kw	[kW]	[kW]	[kW]	[A]
25	149.0	74.5	149.0	30.3	14.9	30.3	4.92	120.7	60.3	120.7	55.0	
24	146.0	73.0	146.0	30.3	14.9	30.3	4.83	117.8	58.9	117.8	54.9	
23	143.1	71.6	143.1	30.2	14.9	30.2	4.74	114.9	57.5	114.9	54.8	
22	140.3	70.1	140.3	30.2	14.9	30.2	4.65	112.1	56.0	112.1	54.8	
21	137.4	68.7	137.4	30.2	14.9	30.2	4.56	109.3	54.6	109.3	54.7	
20	134.6	67.3	134.6	30.1	14.9	30.1	4.47	106.5	53.3	106.5	54.7	
19	131.9	65.9	131.9	30.1	14.8	30.1	4.38	103.8	51.9	103.8	54.6	
18	129.2	64.6	129.2	30.0	14.8	30.0	4.30	101.1	50.6	101.1	54.6	
17	126.5	63.3	126.5	30.0	14.8	30.0	4.22	98.5	49.2	98.5	54.5	
16	123.9	61.9	123.9	30.0	14.8	30.0	4.13	95.9	47.9	95.9	54.5	
15	121.3	60.7	121.3	29.9	14.8	29.9	4.05	93.3	46.7	93.3	54.4	
14	118.8	59.4	118.8	29.9	14.8	29.9	3.97	90.8	45.4	90.8	54.4	
13	116.2	58.1	116.2	29.9	14.7	29.9	3.89	88.3	44.2	88.3	54.3	
12	113.8	56.9	113.8	29.9	14.7	29.9	3.81	85.9	42.9	85.9	54.3	
11	111.3	55.7	111.3	29.8	14.7	29.8	3.73	83.5	41.7	83.5	54.2	
10	108.9	54.5	108.9	29.8	14.7	29.8	3.66	81.1	40.6	81.1	54.2	
9	106.6	53.3	106.6	29.8	14.7	29.8	3.58	78.8	39.4	78.8	54.2	
8	104.2	52.1	104.2	29.7	14.7	29.7	3.51	76.5	38.2	76.5	54.1	
7	102.0	51.0	102.0	29.7	14.7	29.7	3.43	74.2	37.1	74.2	54.1	
6	99.7	49.9	99.7	29.7	14.6	29.7	3.36	72.0	36.0	72.0	54.0	
5	97.5	48.7	97.5	29.7	14.6	29.7	3.29	69.8	34.9	69.8	54.0	
4	95.3	47.7	95.3	29.6	14.6	29.6	3.22	67.6	33.8	67.6	54.0	
3	93.2	46.6	93.2	29.6	14.6	29.6	3.15	65.5	32.8	65.5	53.9	
2	91.1	45.5	91.1	29.6	14.6	29.6	3.08	63.4	31.7	63.4	53.9	
1	89.0	44.5	89.0	29.6	14.6	29.6	3.01	61.4	30.7	61.4	53.9	
0	87.0	43.5	87.0	29.5	14.6	29.5	2.94	59.4	29.7	59.4	53.8	
-1	85.0	42.5	85.0	29.5	14.6	29.5	2.88	57.4	28.7	57.4	53.8	
-2	83.0	41.5	83.0	29.5	14.6	29.5	2.81	55.4	27.7	55.4	53.8	
-3	81.1	40.5	81.1	29.5	14.5	29.5	2.75	53.5	26.8	53.5	53.7	
-4	79.2	39.6	79.2	29.5	14.5	29.5	2.69	51.7	25.8	51.7	53.7	
-5	77.3	38.7	77.3	29.5	14.5	29.5	2.62	49.8	24.9	49.8	53.7	
-6	75.5	37.7	75.5	29.4	14.5	29.4	2.56	48.0	24.0	48.0	53.6	
-7	73.7	36.8	73.7	29.4	14.5	29.4	2.50	46.2	23.1	46.2	53.6	
-8	71.9	36.0	71.9	29.4	14.5	29.4	2.45	44.5	22.2	44.5	53.6	
-9	70.2	35.1	70.2	29.4	14.5	29.4	2.39	42.7	21.4	42.7	53.6	
-10	68.5	34.3	68.5	29.4	14.5	29.4	2.33	41.1	20.5	41.1	53.5	
-11	66.9	33.4	66.9	29.4	14.5	29.4	2.27	39.4	19.7	39.4	53.5	
-12	65.2	32.6	65.2	29.4	14.5	29.4	2.22	37.8	18.9	37.8	53.5	
-13	63.6	31.8	63.6	29.4	14.5	29.4	2.17	36.2	18.1	36.2	53.4	
-14	62.1	31.0	62.1	29.4	14.5	29.4	2.11	34.6	17.3	34.6	53.4	
-15	60.5	30.3	60.5	29.4	14.5	29.4	2.06	33.1	16.5	33.1	53.4	

-- Achtung: Betriebsgrenzen beachten - nicht in Tabelle festgehalten

Tws -VL	65 (T-max)										
	[°C]	Qh nom	Qh min	Qh max	Pin nom	Pin min	Pin max	COP nom	Qc nom	Qc min	Qc max
[°C]	[kW]	[kW]	[kW]	[kW]	[kW]	[kW]	kW / kW	[kW]	[kW]	[kW]	[A]
25	<b>148.5</b>	74.3	148.5	<b>38.9</b>	19.2	38.9	<b>3.82</b>	112.2	56.1	112.2	65.8
24	<b>145.7</b>	72.9	145.7	<b>38.8</b>	19.2	38.8	<b>3.75</b>	109.4	54.7	109.4	65.7
23	<b>143.0</b>	71.5	143.0	<b>38.8</b>	19.1	38.8	<b>3.68</b>	106.7	53.4	106.7	65.7
22	<b>140.2</b>	70.1	140.2	<b>38.8</b>	19.1	38.8	<b>3.62</b>	104.0	52.0	104.0	65.6
21	<b>137.5</b>	68.8	137.5	<b>38.7</b>	19.1	38.7	<b>3.55</b>	101.4	50.7	101.4	65.6
20	<b>134.9</b>	67.4	134.9	<b>38.7</b>	19.1	38.7	<b>3.49</b>	98.8	49.4	98.8	65.5
19	<b>132.3</b>	66.1	132.3	<b>38.6</b>	19.1	38.6	<b>3.42</b>	96.2	48.1	96.2	65.5
18	<b>129.7</b>	64.8	129.7	<b>38.6</b>	19.0	38.6	<b>3.36</b>	93.6	46.8	93.6	65.4
17	<b>127.1</b>	63.6	127.1	<b>38.6</b>	19.0	38.6	<b>3.30</b>	91.1	45.6	91.1	65.4
16	<b>124.6</b>	62.3	124.6	<b>38.5</b>	19.0	38.5	<b>3.24</b>	88.7	44.3	88.7	65.4
15	<b>122.2</b>	61.1	122.2	<b>38.5</b>	19.0	38.5	<b>3.17</b>	86.2	43.1	86.2	65.3
14	<b>119.7</b>	59.9	119.7	<b>38.4</b>	19.0	38.4	<b>3.11</b>	83.8	41.9	83.8	65.3
13	<b>117.4</b>	58.7	117.4	<b>38.4</b>	18.9	38.4	<b>3.06</b>	81.5	40.7	81.5	65.3
12	<b>115.0</b>	57.5	115.0	<b>38.4</b>	18.9	38.4	<b>3.00</b>	79.2	39.6	79.2	65.2
11	<b>112.7</b>	56.3	112.7	<b>38.3</b>	18.9	38.3	<b>2.94</b>	76.9	38.4	76.9	65.2
10	<b>110.4</b>	55.2	110.4	<b>38.3</b>	18.9	38.3	<b>2.88</b>	74.6	37.3	74.6	65.2
9	<b>108.1</b>	54.1	108.1	<b>38.3</b>	18.9	38.3	<b>2.83</b>	72.4	36.2	72.4	65.2
8	<b>105.9</b>	53.0	105.9	<b>38.3</b>	18.9	38.3	<b>2.77</b>	70.2	35.1	70.2	65.1
7	<b>103.8</b>	51.9	103.8	<b>38.2</b>	18.9	38.2	<b>2.71</b>	68.1	34.0	68.1	65.1
6	<b>101.6</b>	50.8	101.6	<b>38.2</b>	18.8	38.2	<b>2.66</b>	65.9	33.0	65.9	65.1
5	<b>99.5</b>	49.7	99.5	<b>38.2</b>	18.8	38.2	<b>2.61</b>	63.9	31.9	63.9	65.1
4	<b>97.4</b>	48.7	97.4	<b>38.1</b>	18.8	38.1	<b>2.55</b>	61.8	30.9	61.8	65.1
3	<b>95.4</b>	47.7	95.4	<b>38.1</b>	18.8	38.1	<b>2.50</b>	59.8	29.9	59.8	65.1
2	<b>93.4</b>	46.7	93.4	<b>38.1</b>	18.8	38.1	<b>2.45</b>	57.8	28.9	57.8	65.1
1	<b>91.4</b>	45.7	91.4	<b>38.1</b>	18.8	38.1	<b>2.40</b>	55.8	27.9	55.8	65.1
0	<b>89.5</b>	44.7	89.5	<b>38.0</b>	18.8	38.0	<b>2.35</b>	53.9	27.0	53.9	65.1
-1	<b>87.5</b>	43.8	87.5	<b>38.0</b>	18.8	38.0	<b>2.30</b>	52.0	26.0	52.0	65.1
-2	<b>85.7</b>	42.8	85.7	<b>38.0</b>	18.7	38.0	<b>2.25</b>	50.2	25.1	50.2	65.1
-3	<b>83.8</b>	41.9	83.8	<b>38.0</b>	18.7	38.0	<b>2.21</b>	48.3	24.2	48.3	65.1
-4	<b>82.0</b>	41.0	82.0	<b>38.0</b>	18.7	38.0	<b>2.16</b>	46.6	23.3	46.6	65.1
-5	<b>80.2</b>	40.1	80.2	<b>38.0</b>	18.7	38.0	<b>2.11</b>	44.8	22.4	44.8	65.1
-6	<b>78.5</b>	39.2	78.5	<b>37.9</b>	18.7	37.9	<b>2.07</b>	43.0	21.5	43.0	65.1
-7	<b>76.8</b>	38.4	76.8	<b>37.9</b>	18.7	37.9	<b>2.02</b>	41.3	20.7	41.3	65.1
-8	<b>75.1</b>	37.5	75.1	<b>37.9</b>	18.7	37.9	<b>1.98</b>	39.7	19.8	39.7	65.1
-9	<b>73.4</b>	36.7	73.4	<b>37.9</b>	18.7	37.9	<b>1.94</b>	38.0	19.0	38.0	65.1
-10	<b>71.8</b>	35.9	71.8	<b>37.9</b>	18.7	37.9	<b>1.89</b>	36.4	18.2	36.4	65.1
-11	<b>70.2</b>	35.1	70.2	<b>37.9</b>	18.7	37.9	<b>1.85</b>	34.8	17.4	34.8	65.1
-12	<b>68.6</b>	34.3	68.6	<b>37.9</b>	18.7	37.9	<b>1.81</b>	33.3	16.6	33.3	65.1
-13	<b>67.1</b>	33.6	67.1	<b>37.9</b>	18.7	37.9	<b>1.77</b>	31.7	15.9	31.7	65.1
-14	<b>65.6</b>	32.8	65.6	<b>37.9</b>	18.7	37.9	<b>1.73</b>	30.2	15.1	30.2	65.1
-15	<b>64.1</b>	32.1	64.1	<b>37.9</b>	18.7	37.9	<b>1.69</b>	28.7	14.4	28.7	65.2

-- Achtung: Betriebsgrenzen beachten - nicht in Tabelle festgehalten

Tk -VL	W 12 / 7 °C										
[°C]	Qc nom [kW]	Qc min [kW]	Qc max [kW]	Pin nom [kW]	Pin min [kW]	Pin max [kW]	EER kW / kW	Qh nom [kW]	Qh min [kW]	Qh max [kW]	I nom [A]
40	60.7	30.4	60.7	24.9	12.3	24.9	2.44	84.0	42.0	84.0	49.0
39	61.2	30.6	61.2	24.4	12.0	24.4	2.51	83.9	42.0	83.9	48.5
38	61.6	30.8	61.6	23.8	11.7	23.8	2.59	83.8	41.9	83.8	48.0
37	62.1	31.0	62.1	23.3	11.5	23.3	2.67	83.8	41.9	83.8	47.5
36	62.5	31.2	62.5	22.7	11.2	22.7	2.75	83.7	41.9	83.7	47.1
35	62.9	31.4	62.9	22.2	11.0	22.2	2.83	83.7	41.8	83.7	46.6
34	63.3	31.7	63.3	21.7	10.7	21.7	2.91	83.6	41.8	83.6	46.2
33	63.7	31.9	63.7	21.3	10.5	21.3	3.00	83.6	41.8	83.6	45.8
32	64.1	32.0	64.1	20.8	10.3	20.8	3.08	83.5	41.8	83.5	45.4
31	64.5	32.2	64.5	20.3	10.0	20.3	3.17	83.5	41.7	83.5	45.1
30	64.9	32.4	64.9	19.9	9.8	19.9	3.26	83.5	41.7	83.5	44.7
29	65.2	32.6	65.2	19.5	9.6	19.5	3.35	83.4	41.7	83.4	44.3
28	65.6	32.8	65.6	19.1	9.4	19.1	3.44	83.4	41.7	83.4	44.0
27	65.9	33.0	65.9	18.7	9.2	18.7	3.53	83.4	41.7	83.4	43.6
26	66.3	33.1	66.3	18.3	9.0	18.3	3.62	83.4	41.7	83.4	43.2
25	66.6	33.3	66.6	17.9	8.8	17.9	3.72	83.4	41.7	83.4	42.9
24	66.9	33.5	66.9	17.6	8.7	17.6	3.81	83.3	41.7	83.3	42.5
23	67.3	33.6	67.3	17.2	8.5	17.2	3.91	83.3	41.7	83.3	42.1
22	67.6	33.8	67.6	16.9	8.3	16.9	4.01	83.3	41.7	83.3	41.7
21	67.9	33.9	67.9	16.5	8.2	16.5	4.11	83.3	41.7	83.3	41.3
20	68.2	34.1	68.2	16.2	8.0	16.2	4.21	83.3	41.7	83.3	40.8

Tc [°C]	W 23 / 18 °C										
[°C]	Qc nom [kW]	Qc min [kW]	Qc max [kW]	Pin nom [kW]	Pin min [kW]	Pin max [kW]	EER kW / kW	Qh nom [kW]	Qh min [kW]	Qh max [kW]	I nom [A]
0											
40	82.7	41.4	82.7	24.9	12.3	24.9	3.32	106.2	53.1	106.9	49.4
39	83.3	41.6	83.3	24.4	12.0	24.4	3.42	106.2	53.1	106.8	48.8
38	83.8	41.9	83.8	23.8	11.7	23.8	3.52	106.2	53.1	106.7	48.3
37	84.3	42.2	84.3	23.3	11.5	23.3	3.62	106.2	53.1	106.6	47.8
36	84.8	42.4	84.8	22.7	11.2	22.7	3.73	106.2	53.1	106.5	47.3
35	85.3	42.7	85.3	22.2	11.0	22.2	3.84	106.3	53.1	106.4	46.9
34	85.8	42.9	85.8	21.7	10.7	21.7	3.95	106.3	53.1	106.4	46.4
33	86.3	43.1	86.3	21.3	10.5	21.3	4.06	106.3	53.2	106.3	46.0
32	86.7	43.4	86.7	20.8	10.3	20.8	4.17	106.3	53.2	106.3	45.6
31	87.2	43.6	87.2	20.3	10.0	20.3	4.29	106.4	53.2	106.3	45.2
30	87.6	43.8	87.6	19.9	9.8	19.9	4.40	106.4	53.2	106.2	44.7
29	88.1	44.0	88.1	19.5	9.6	19.5	4.52	106.5	53.2	106.2	44.3
28	88.5	44.3	88.5	19.1	9.4	19.1	4.64	106.5	53.3	106.2	43.9
27	88.9	44.5	88.9	18.7	9.2	18.7	4.76	106.5	53.3	106.2	43.5
26	89.3	44.7	89.3	18.3	9.0	18.3	4.88	106.6	53.3	106.2	43.1
25	89.7	44.9	89.7	17.9	8.8	17.9	5.01	106.6	53.3	106.3	42.7
24	90.1	45.1	90.1	17.6	8.7	17.6	5.13	106.7	53.3	106.3	42.2
23	90.5	45.3	90.5	17.2	8.5	17.2	5.26	106.7	53.4	106.3	41.8
22	90.9	45.4	90.9	16.9	8.3	16.9	5.39	106.8	53.4	106.3	41.3
21	91.2	45.6	91.2	16.5	8.2	16.5	5.52	106.8	53.4	106.4	40.8
20	91.6	45.8	91.6	16.2	8.0	16.2	5.65	106.9	53.4	106.4	40.3

-- Achtung: Betriebsgrenzen beachten - nicht in Tabelle festgehalten

LEGENDE:

$T_{wq-RL}$ : Temperatur Wärmequelle - Eintritt [°C]

$T_{ws-VL}$ : Temperatur Wärmesenke - Vorlauf [°C]

$T_{k-VL}$ : Temperatur Kältesenke - Vorlauf [°C]

$Q_h$  nom: Heizleistung nominal

$Q_h$  min: Heizleistung minimal

$Q_h$  max: Heizleistung maximal

$P_{in}$  nom: Aufnahme bei nominaler Heizleistung

$P_{in}$  min: Aufnahme bei minimaler Heizleistung

$P_{in}$  max: Aufnahme bei maximaler Heizleistung

COP nom: Arbeitszahl bei nominaler Heizleistung

$Q_c$  nom: Kälteleistung/Energieentnahme bei nominaler Heizleistung

$Q_c$  min: Kälteleistung/Energieentnahme bei minimaler Heizleistung

$Q_c$  max: Kälteleistung/Energieentnahme bei maximaler Heizleistung

$I$  nom: Stromaufnahme bei nominaler Heizleistung

EER: Arbeitszahl bei nominaler Kälteleistung

### Betriebsgrenzen

Temp °C

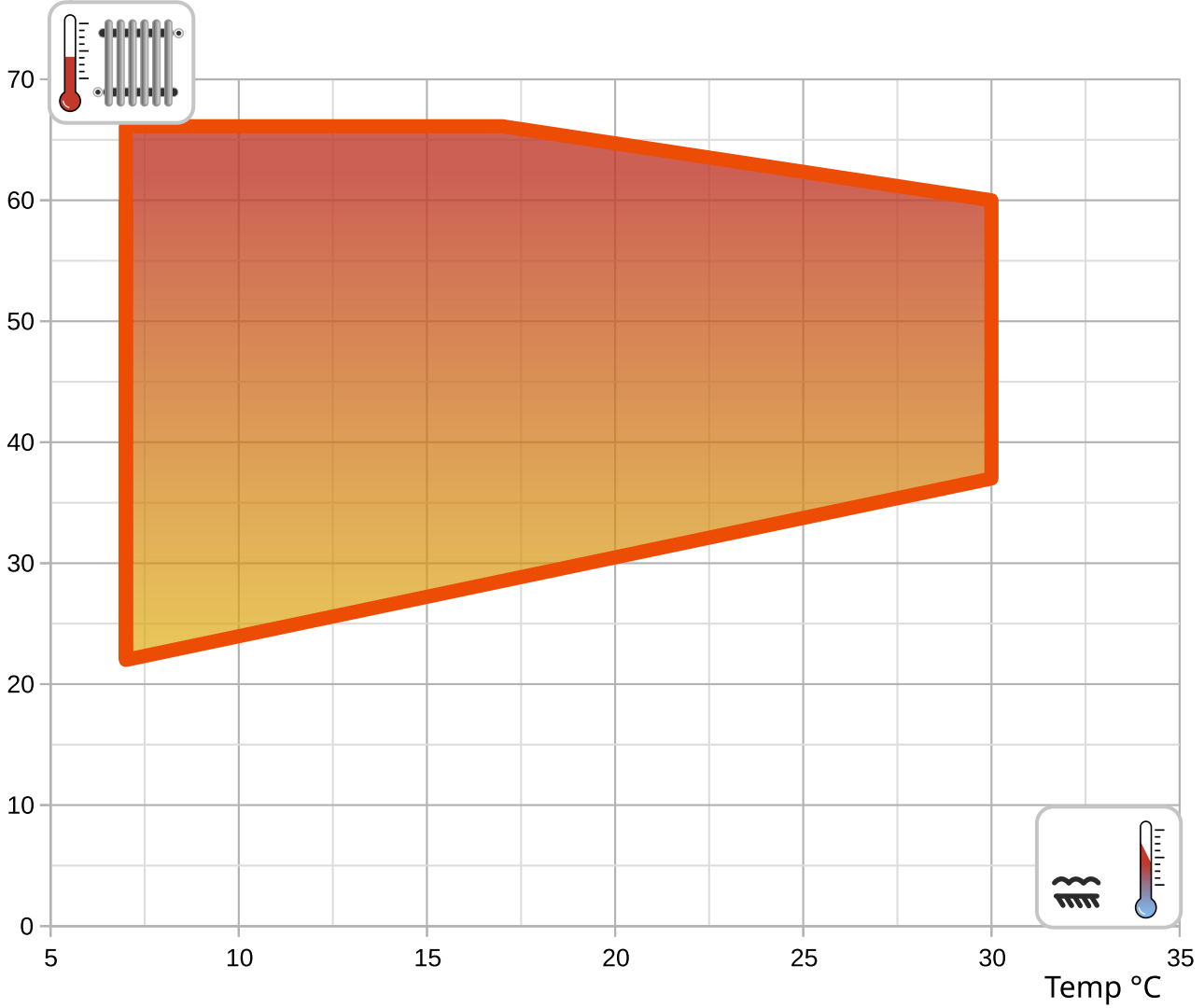

Temp °C

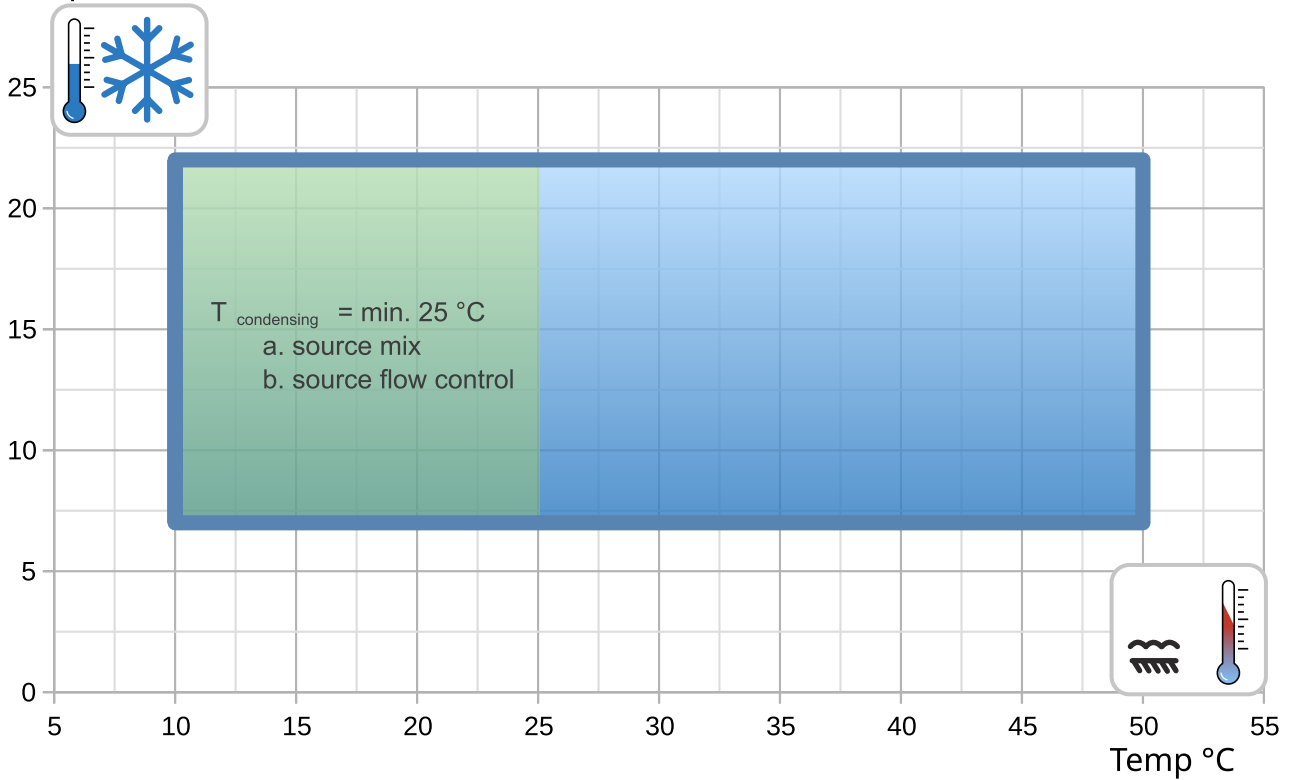

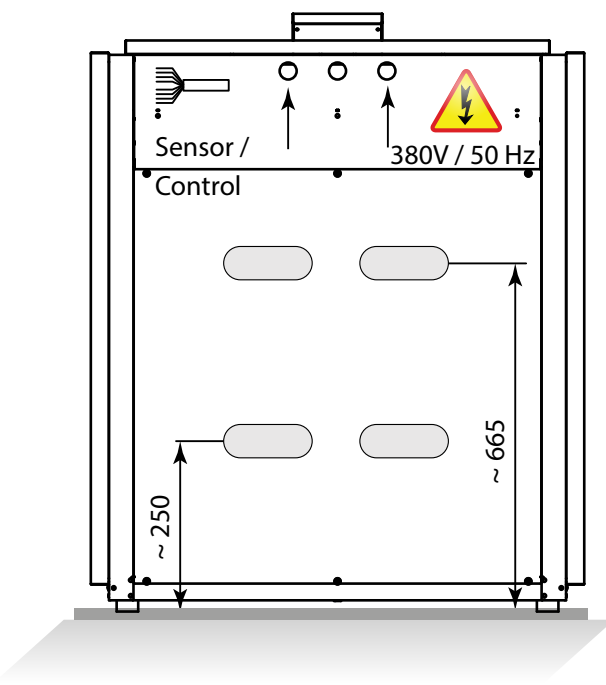
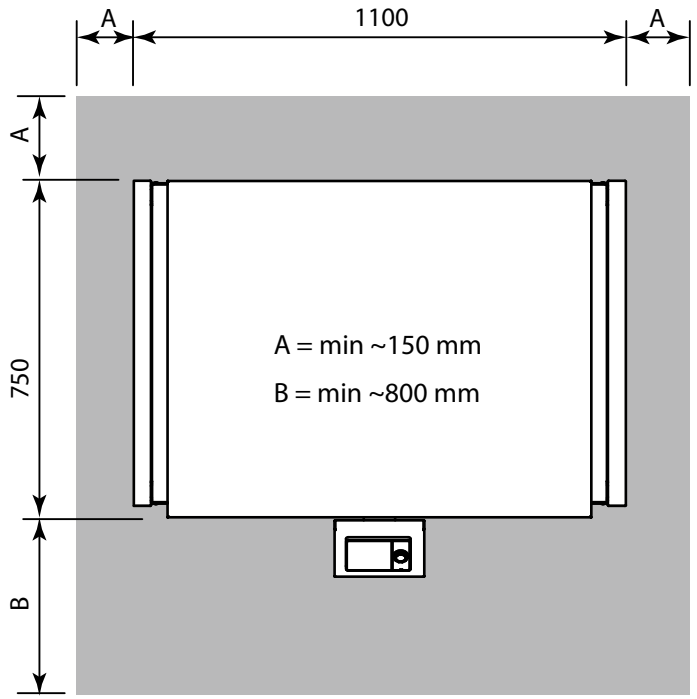
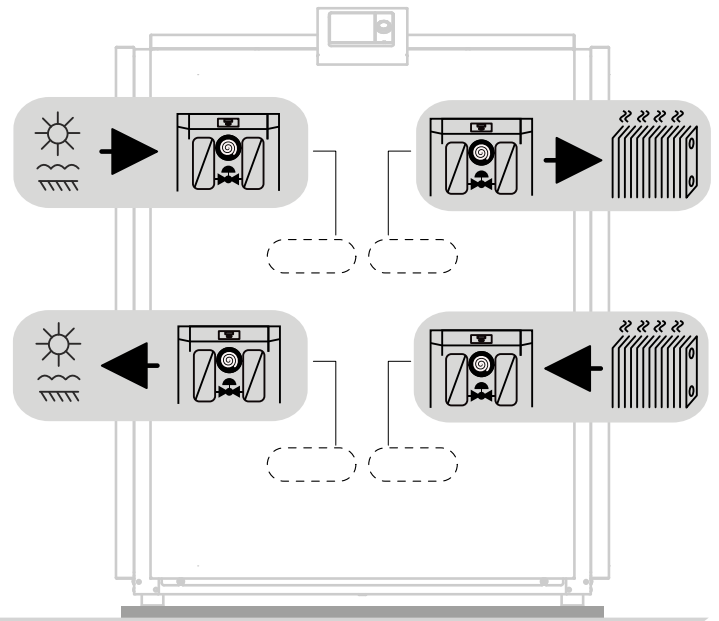
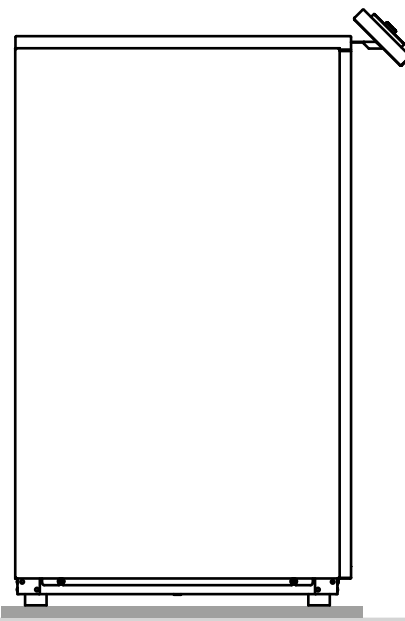
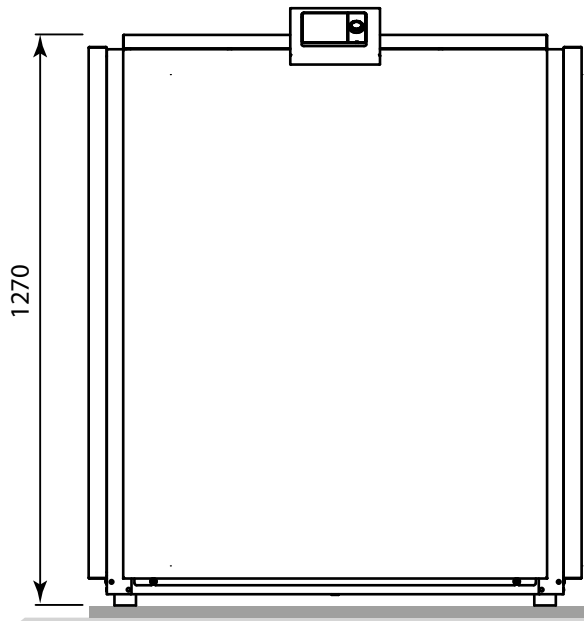

int. code: VN1100

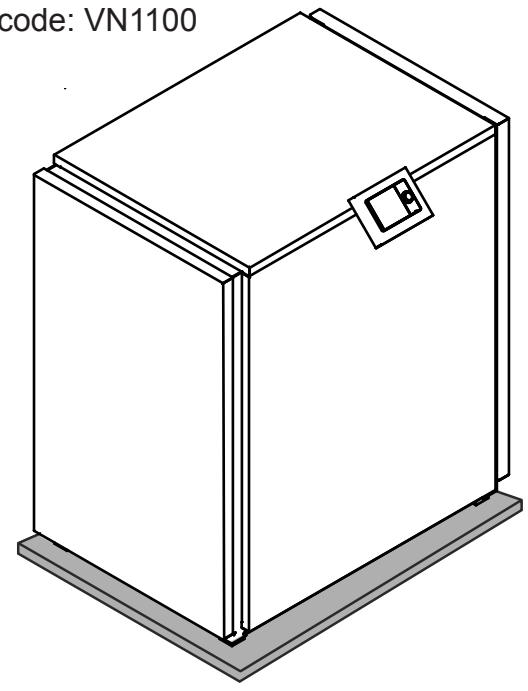

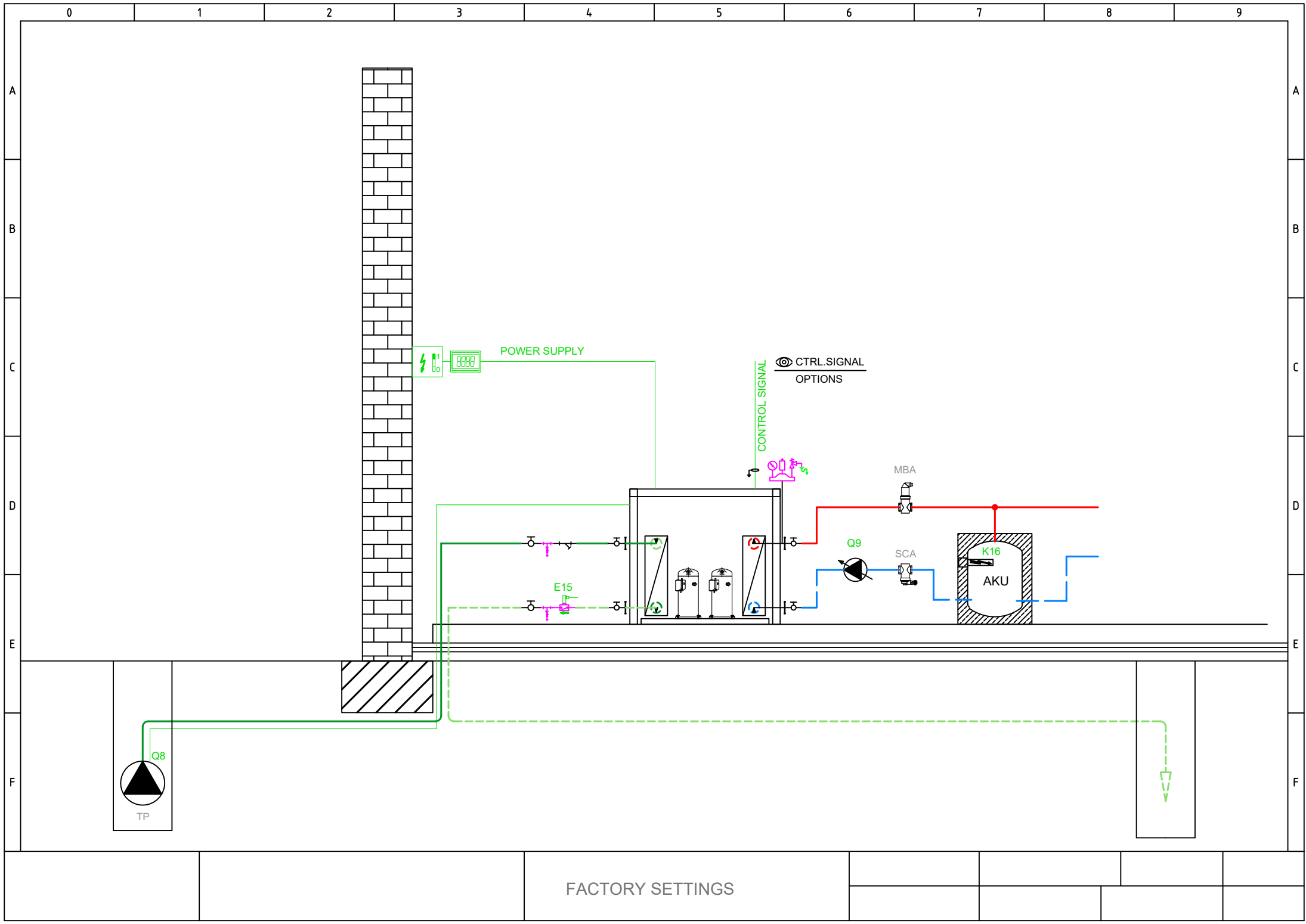

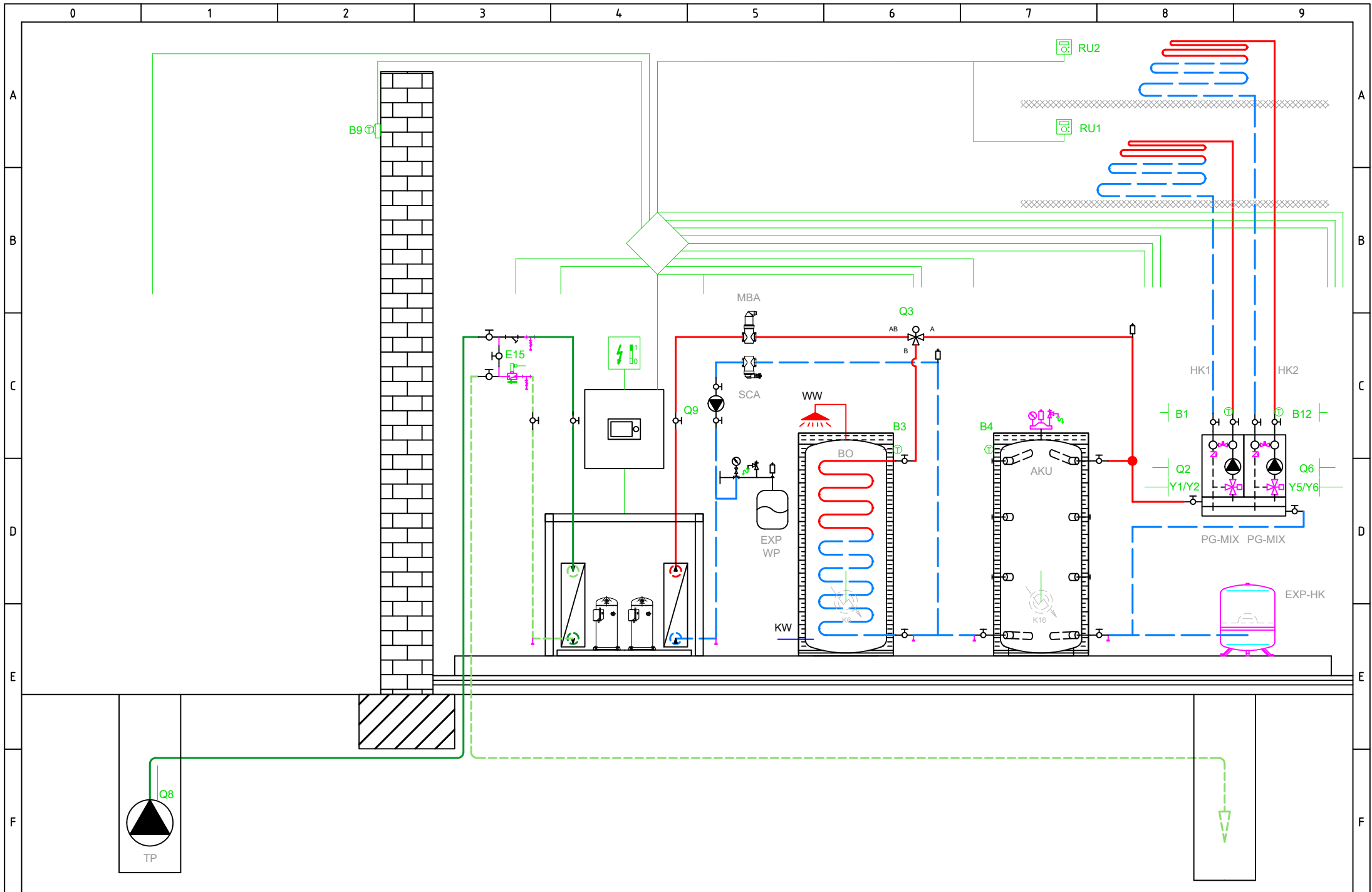

BASIC APPLICATION

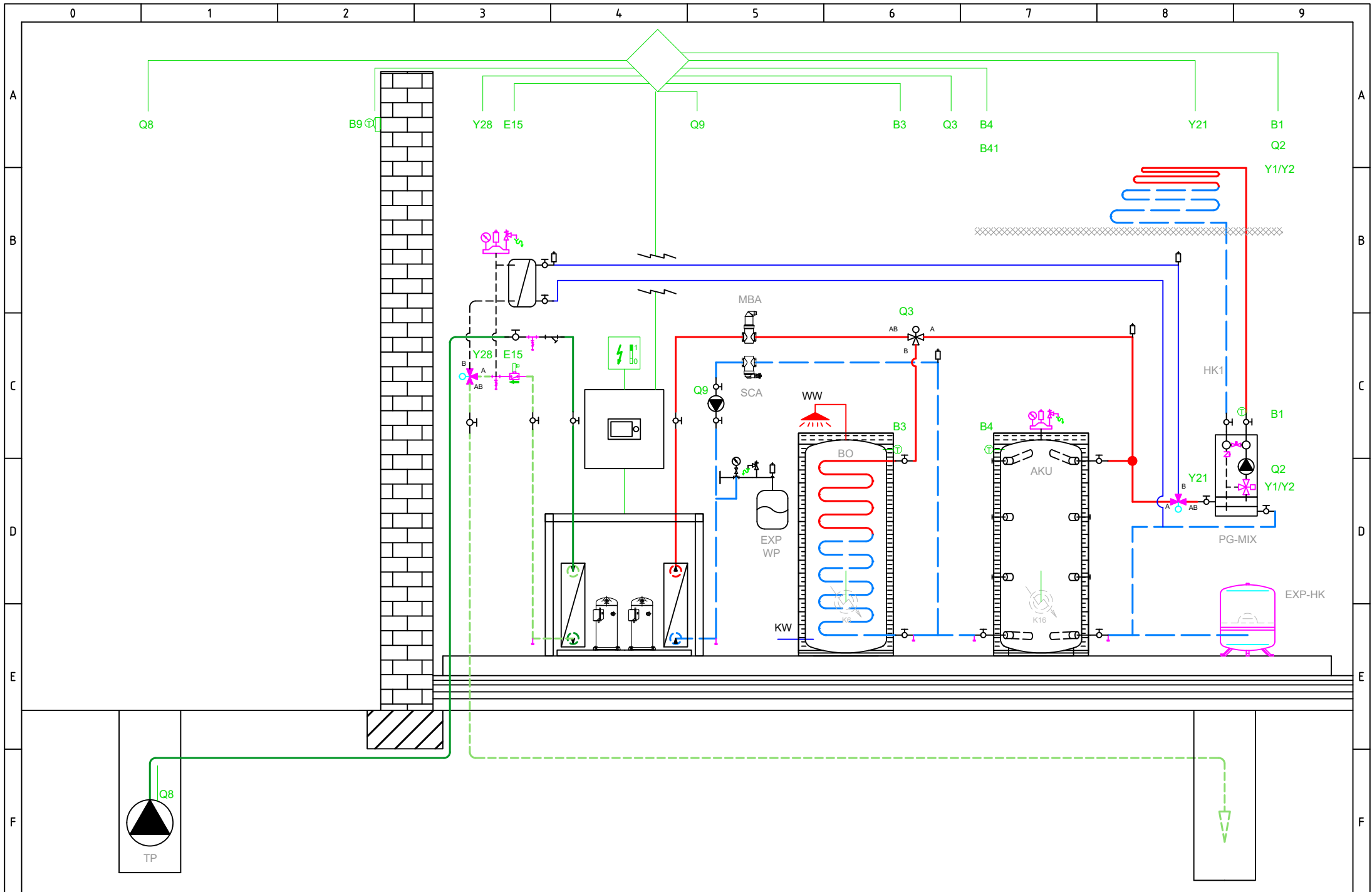

OPTIONAL APPLICATION

Total: max 6A  
1 x QX...: max 2A

Netzanschluss 230V / 50 Hz  
Erde  
Nullleiter

E9	Niederdruckwächter E9
E10	Hochdruckwächter E10
E15	Ström'wächter Quelle E15
E24	Ström'wächter Verbrau E24
E6	EW Sperre E6
E12	Überlast Verdichter 2 E12
E21	Drehstrom E21
E22	Drehstrom E22
E23	Drehstrom E23
E11	Überlast Verdichter 1 E11
K1	Verdichterstufe 1 K1

Q8 Quellpumpe Q8

Q9 Kondensatorpumpe Q9

K10 Alarmausgang K10

K40 Ölumpfheizung K40

K81 Ventil Verdampfer K81

K82 Ventil EVI K82

K2 Verdichterstufe 2 K2

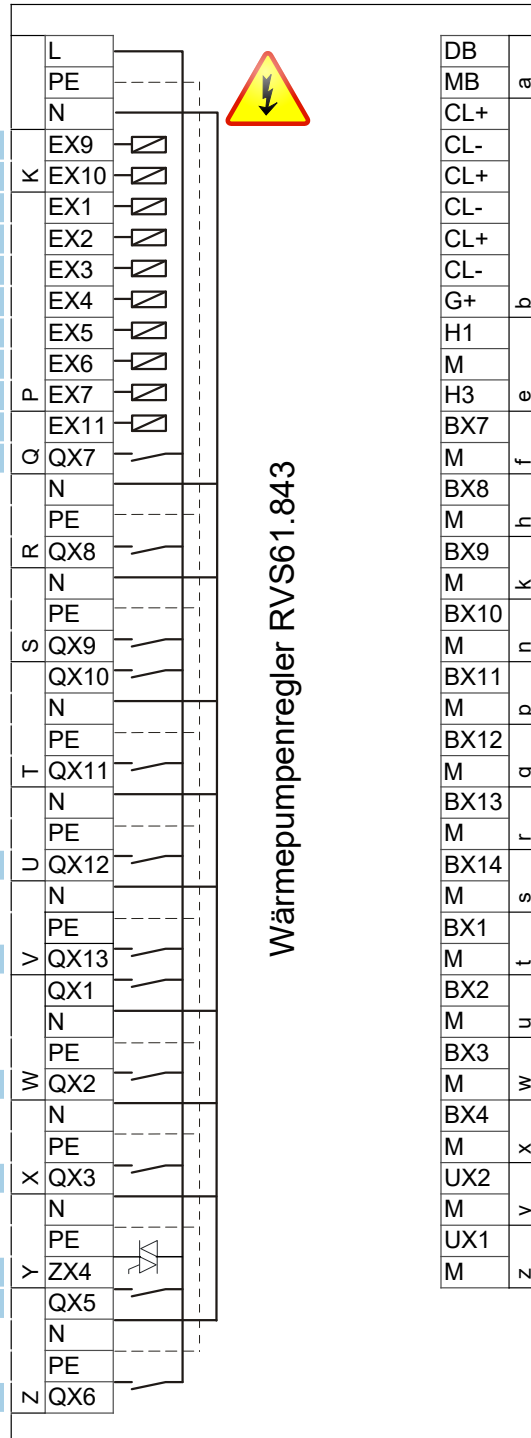

DB		LPB Bus Data
MB	a	LPB Bus Masse
CL+		Raumgerät QAA...
CL-		Raumgerät QAA... 2.
CL+		Raumgerät QAA... 2.
CL-		Raumgerät QAA... 2.
CL+		Raumgerät QAA... 3.
CL-		Raumgerät QAA... 3.
G+	b	12V Versorgung → AUS
H1		
M		
H3	e	Verbr'anforderung VK1
BX7		B81 Heissgasfühler K1 B81
M	f	
BX8		
M	h	
BX9		
M	k	B21 WP Vorlauffühler B21
BX10		
M	n	
BX11		
M	p	B71 WP Rücklauffühler B71
BX12		
M	q	B91 Quelleneintrittfühler B91
BX13		
M	r	B84 Quellenaust'fühler B92/B84
BX14		
M	s	
BX1		
M	t	
BX2		
M	u	
BX3		B83 Kältemittelfühler flüssig B83
M	w	
BX4		B82 Heissgasfühler K2 B82
M	x	
UX2		Kondensatorpumpe Q9
M	y	0..10V Analogsignal
UX1		Quell'pumpe Q8
M	z	0..10V Analogsignal



- AVS75.390
- AVS75.391
- AVS75.370

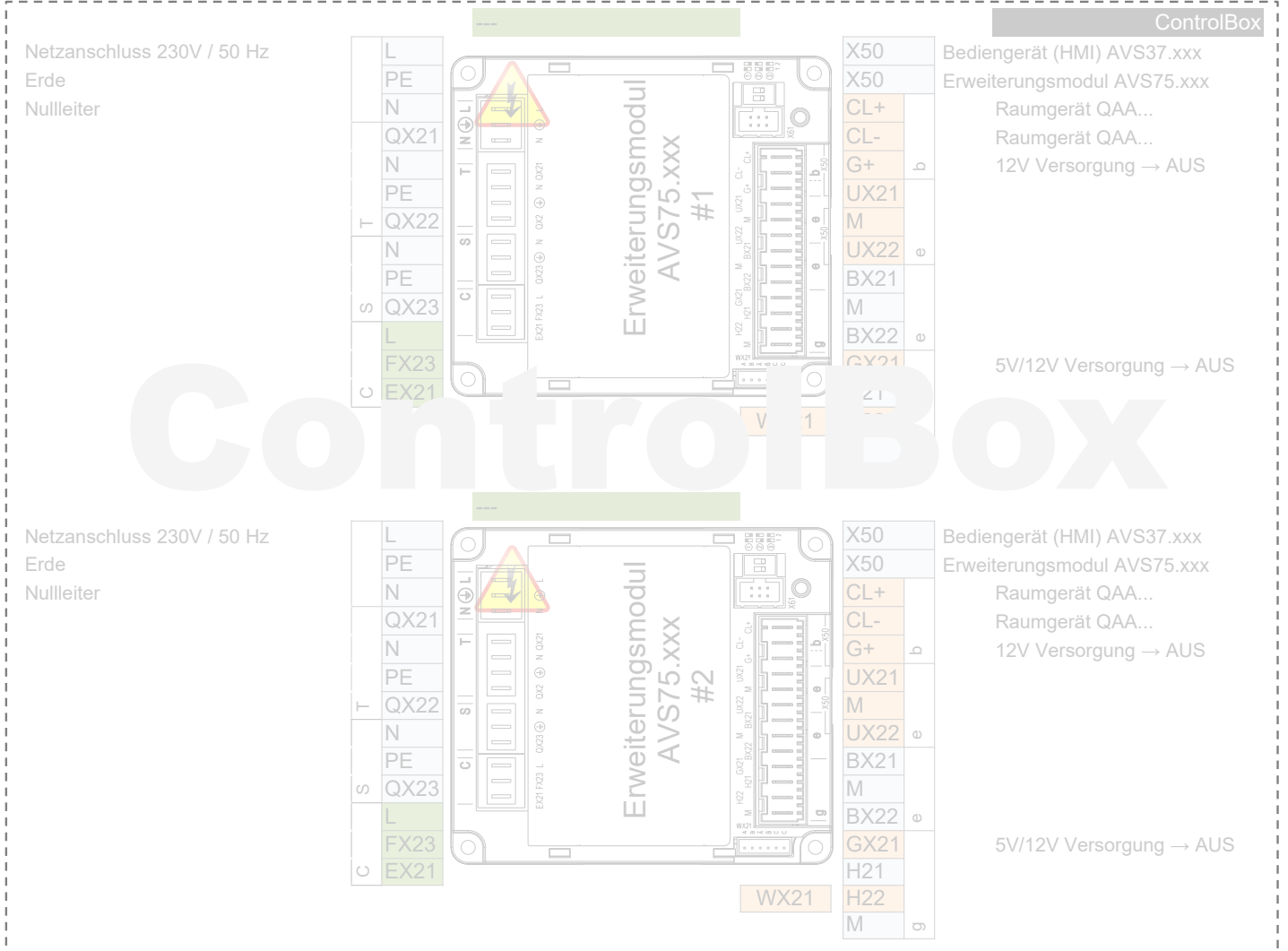

HEAT PUMP

EXTERNAL  
INTERNAL

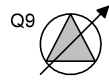
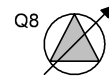

K1

K2

K82

K81

K40

K10

Q8 UX1

Q9 UX2

E11  
KRW1  
F1K  
E11

E12  
KRW2  
F2K  
E12

E6

Q9 ERR  
F1S  
E24

Q8.ERR  
F1Z  
E15

E10

E9

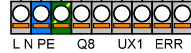
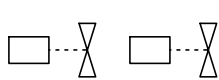

230V,50Hz max 6A

0...10V



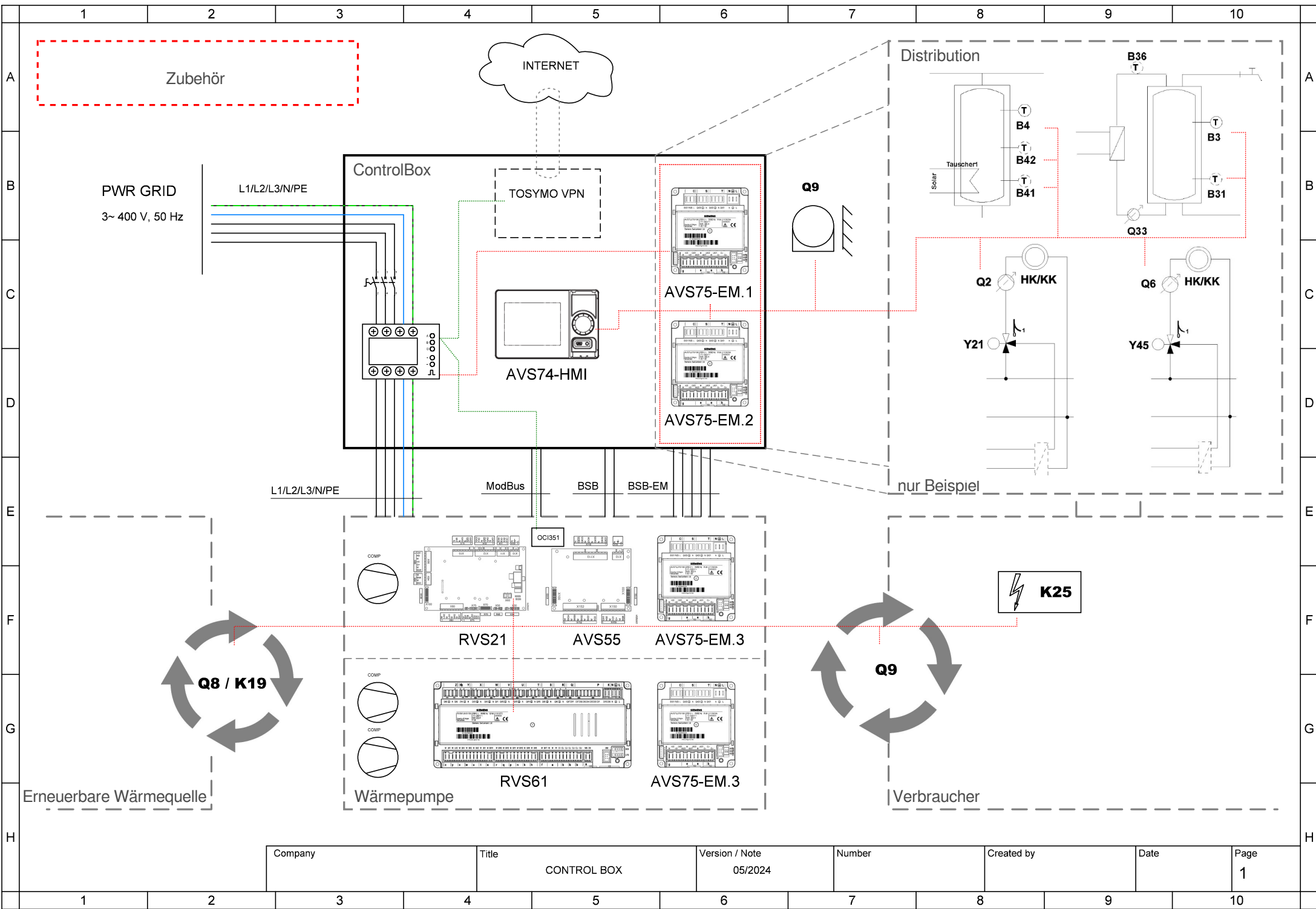

Company	Title	Version / Note	Number	Created by	Date	Page
	CONTROL BOX	05/2024				1



Company	Title	Version / Note	Number	Created by	Date	Page
	CONTROL BOX	05/2024				2



Company	Title	Version / Note	Number	Created by	Date	Page
	CONTROL BOX	05/2024				3



Company	Title	Version / Note	Number	Created by	Date	Page
	CONTROL BOX	05/2024				4



- AVS75.390
- AVS75.391
- AVS75.370

- AVS75.370**  
 Netzanschluss 230V / 50 Hz  
 Erde  
 Nullleiter  
**Y1** Mischer Auf  
  
**Y2** Mischer Zu  
  
**Q2** Heizkreispumpe HK1 Q2  
  
**L** Faze 230V  
**E61** Smart Grid E61

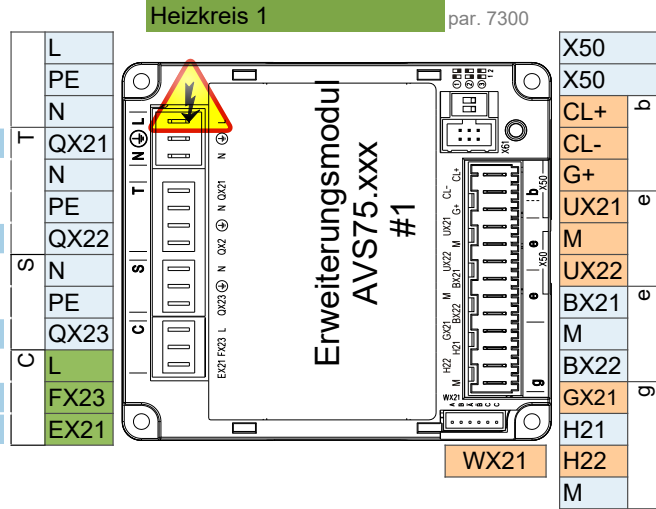

- Erweiterungsmodul AVS75.xxx  
 Raumgerät QAA...  
 Raumgerät QAA...

**B1** Vorlauffühler 1

**Impulszählung**

- AVS75.370**  
 Netzanschluss 230V / 50 Hz  
 Erde  
 Nullleiter  
**Q3** Trinkwasserstellglied Q3  
  
**K6** Elektroeinsetz TWW K6  
  
**Q6** Heizkreispumpe HK2 Q6  
  
**L** Faze 230V  
**E62** Smart Grid E62

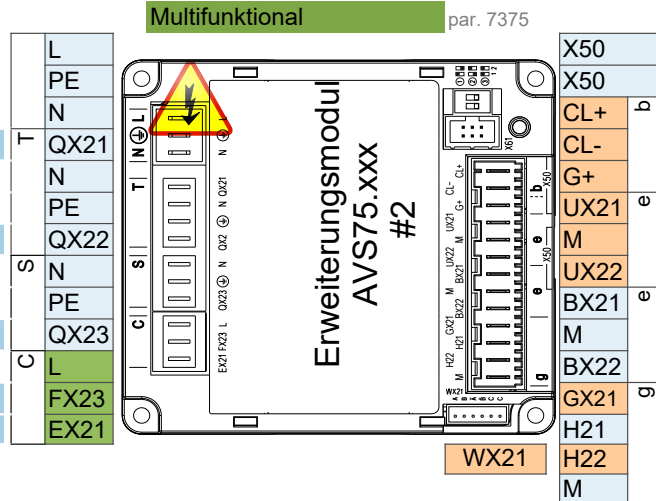

- Bediengerät (HMI) AVS37.xxx  
 Erweiterungsmodul AVS75.xxx  
 Raumgerät QAA...  
 Raumgerät QAA...

**B3** Trinkwasserfühler B3

**B4** Pufferspeicherfühler B4

- Netzanschluss 230V / 50 Hz  
 Erde  
 Nullleiter

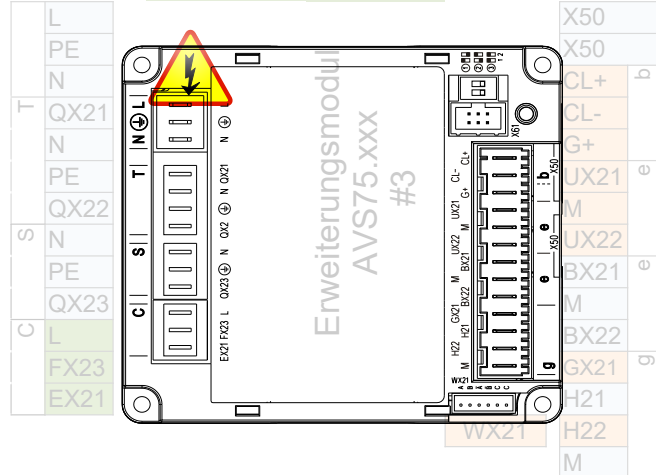

- Bediengerät (HMI) AVS37.xxx  
 Erweiterungsmodul AVS75.xxx  
 Raumgerät QAA...  
 Raumgerät QAA...

Vorsicht: Erweiterungsmodul 3 ist in der Wärmepumpe

## Anschlussmöglichkeiten für die Steuerung

### 1 ControlBox

---

ControlBox, mit zwei eingebauten Erweiterungsmodulen, ermöglicht zahlreiche Optionen für die Anwendungssteuerung auf der Verbraucherseite hinter der Wärmepumpe. Weitere Informationen finden Sie im Schaltplan der ControlBox und im Blatt mit den Anwendungsdiagrammen.

### 2 Fixer Sollwert Vorlauftemperatur - Ein / Aus potentialfreier Kontakt

---

2-adriges abgeschirmtes Kabel 2 x 0,5 mm<sup>2</sup> - Sollwert = 45°C (editierbar über Parameter 1859)

Anschlussklemme - siehe Schaltplan

### 3 Analog 0..10V Vorlauftemperatur-Sollwertregelung

---

2 Adern geschirmtes Kabel 2 x 0,5 mm<sup>2</sup> - Sollwert: 0V = 16°C ~ 10V = 60°C ( editierbar im Parametersatz )

Anschlussklemme - siehe Schaltplan

### 4 ModBus RTU-Kommunikationsbefehl

---

3-adriges abgeschirmtes Kabel min. 3 x 0,25mm<sup>2</sup>

Für die ModBus-Zuordnungstabelle wenden Sie sich bitte an den technischen Support

### 5 MQTT IoT-Kommunikationsprotokoll

---

Für weitere Informationen wenden Sie sich bitte an den technischen Support